

CHAPTER 6

WALL CONSTRUCTION

SECTION R601 GENERAL

R601.1 Application. The provisions of this chapter shall control the design and construction of all walls and partitions for all buildings.

R601.2 Requirements. Wall construction shall be capable of accommodating all loads imposed according to Section R301 and of transmitting the resulting loads to the supporting structural elements.

R601.2.1 Compressible floor-covering materials. Compressible floor-covering materials that compress more than $\frac{1}{32}$ inch (0.8 mm) when subjected to 50 pounds (23 kg) applied over 1 inch square (645 mm) of material and are greater than $\frac{1}{8}$ inch (3 mm) in thickness in the uncompressed state shall not extend beneath walls, partitions or columns, which are fastened to the floor.

SECTION R602 WOOD WALL FRAMING

R602.1 Identification. Load-bearing dimension lumber for studs, plates and headers shall be identified by a grade mark of a lumber grading or inspection agency that has been approved by an accreditation body that complies with DOC PS 20. In lieu of a grade mark, a certification of inspection issued by a lumber grading or inspection agency meeting the requirements of this section shall be accepted.

R602.1.1 End-jointed lumber. Approved end-jointed lumber identified by a grade mark conforming to Section R602.1 may be used interchangeably with solid-sawn members of the same species and grade.

R602.1.2 Structural glued laminated timbers. Glued laminated timbers shall be manufactured and identified as required in AITC A190.1 and ASTM D 3737.

R602.1.3 Structural log members. Stress grading of structural log members of nonrectangular shape, as typically used in log buildings, shall be in accordance with ASTM D 3957. Such structural log members shall be identified by the grade mark of an approved lumber grading or inspection agency. In lieu of a grade mark on the material, a certificate of inspection as to species and grade issued by a lumber-grading or inspection agency meeting the requirements of this section shall be permitted to be accepted.

R602.2 Grade. Studs shall be a minimum No. 3, standard or stud grade lumber.

Exception: Bearing studs not supporting floors and nonbearing studs may be utility grade lumber, provided the studs are spaced in accordance with Table R602.3(5).

R602.3 Design and construction. Exterior walls of wood-light-framed construction shall be designed and con-

structed in accordance with the provisions of this chapter and Figures R602.3(1) and R602.3(2) or in accordance with AF&PA's NDS. Components of exterior walls shall be fastened in accordance with Tables R602.3(1) through R602.3(4). Exterior walls covered with foam plastic sheathing shall be braced in accordance with Section R602.10. Structural sheathing shall be fastened directly to structural framing members.

R602.3.1 Stud size, height and spacing. The size, height and spacing of studs shall be in accordance with Table R602.3(5).

Exceptions:

1. Utility grade studs shall not be spaced more than 16 inches (406 mm) on center, shall not support more than a roof and ceiling, and shall not exceed 8 feet (2438 mm) in height for exterior walls and load-bearing walls or 10 feet (3048 mm) for interior nonload-bearing walls.
2. Studs more than 10 feet (3048 mm) in height which are in accordance with Table R602.3.1.

R602.3.2 Top plate. Wood stud walls shall be capped with a double top plate installed to provide overlapping at corners and intersections with bearing partitions. End joints in top plates shall be offset at least 24 inches (610 mm). Joints in plates need not occur over studs. Plates shall be not less than 2-inches (51 mm) nominal thickness and have a width at least equal to the width of the studs.

Exception: A single top plate may be installed in stud walls, provided the plate is adequately tied at joints, corners and intersecting walls by a minimum 3-inch-by-6-inch by a 0.036-inch-thick (76 mm by 152 mm by 0.914 mm) galvanized steel plate that is nailed to each wall or segment of wall by six 8d nails on each side, provided the rafters or joists are centered over the studs with a tolerance of no more than 1 inch (25 mm). The top plate may be omitted over lintels that are adequately tied to adjacent wall sections with steel plates or equivalent as previously described.

R602.3.3 Bearing studs. Where joists, trusses or rafters are spaced more than 16 inches (406 mm) on center and the bearing studs below are spaced 24 inches (610 mm) on center, such members shall bear within 5 inches (127 mm) of the studs beneath.

Exceptions:

1. The top plates are two 2-inch by 6-inch (38 mm by 140 mm) or two 3-inch by 4-inch (64 mm by 89 mm) members.
2. A third top plate is installed.
3. Solid blocking equal in size to the studs is installed to reinforce the double top plate.

TABLE R602.3(1)
FASTENER SCHEDULE FOR STRUCTURAL MEMBERS

DESCRIPTION OF BUILDING ELEMENTS	NUMBER AND TYPE OF FASTENER ^{a,b,c}	SPACING OF FASTENERS
Joist to sill or girder, toe nail	3-8d (2-1/2" × 0.113")	—
1" × 6" subfloor or less to each joist, face nail	2-8d (2-1/2" × 0.113") 2 staples, 1-3/4"	— —
2" subfloor to joist or girder, blind and face nail	2-16d (3-1/2" × 0.135")	—
Sole plate to joist or blocking, face nail	16d (3-1/2" × 0.135")	16" o.c.
Top or sole plate to stud, end nail	2-16d (3-1/2" × 0.135")	—
Stud to sole plate, toe nail	3-8d (2-1/2" × 0.113") or 2-16d (3-1/2" × 0.135")	—
Double studs, face nail	10d (3" × 0.128")	24" o.c.
Double top plates, face nail	10d (3" × 0.128")	24" o.c.
Sole plate to joist or blocking at braced wall panels	3-16d (3-1/2" × 0.135")	16" o.c.
Double top plates, minimum 24-inch offset of end joints, face nail in lapped area	8-16d (3-1/2" × 0.135")	—
Blocking between joists or rafters to top plate, toe nail	3-8d (2-1/2" × 0.113")	—
Rim joist to top plate, toe nail	8d (2-1/2" × 0.113")	6" o.c.
Top plates, laps at corners and intersections, face nail	2-10d (3" × 0.128")	—
Built-up header, two pieces with 1/2" spacer	16d (3-1/2" × 0.135")	16" o.c. along each edge
Continued header, two pieces	16d (3-1/2" × 0.135")	16" o.c. along each edge
Ceiling joists to plate, toe nail	3-8d (2-1/2" × 0.113")	—
Continuous header to stud, toe nail	4-8d (2-1/2" × 0.113")	—
Ceiling joist, laps over partitions, face nail	3-10d (3" × 0.128")	—
Ceiling joist to parallel rafters, face nail	3-10d (3" × 0.128")	—
Rafter to plate, toe nail	2-16d (3-1/2" × 0.135")	—
1" brace to each stud and plate, face nail	2-8d (2-1/2" × 0.113") 2 staples, 1-3/4"	— —
1" × 6" sheathing to each bearing, face nail	2-8d (2-1/2" × 0.113") 2 staples, 1-3/4"	— —
1" × 8" sheathing to each bearing, face nail	2-8d (2-1/2" × 0.113") 3 staples, 1-3/4"	— —
Wider than 1" × 8" sheathing to each bearing, face nail	3-8d (2-1/2" × 0.113") 4 staples, 1-3/4"	— —
Built-up corner studs	10d (3" × 0.128")	24" o.c.
Built-up girders and beams, 2-inch lumber layers	10d (3" × 0.128")	Nail each layer as follows: 32" o.c. at top and bottom and staggered. Two nails at ends and at each splice.
2" planks	2-16d (3-1/2" × 0.135")	At each bearing
Roof rafters to ridge, valley or hip rafters: toe nail	4-16d (3-1/2" × 0.135")	—
face nail	3-16d (3-1/2" × 0.135")	—
Rafter ties to rafters, face nail	3-8d (2-1/2" × 0.113")	—
Collar tie to rafter, face nail, or 1-1/4" × 20 gage ridge strap	3-10d (3" × 0.128")	—

(continued)

**TABLE R602.3(1)—continued
FASTENER SCHEDULE FOR STRUCTURAL MEMBERS**

DESCRIPTION OF BUILDING MATERIALS	DESCRIPTION OF FASTENER ^{b, c, e}	SPACING OF FASTENERS	
		Edges (inches) ⁱ	Intermediate supports ^{c, e} (inches)
Wood structural panels, subfloor, roof and wall sheathing to framing, and particleboard wall sheathing to framing			
$5/16''$ - $1/2''$	6d common ($2'' \times 0.113''$) nail (subfloor, wall) 8d common ($2\frac{1}{2}'' \times 0.131''$) nail (roof) ^f	6	12^g
$19/32''$ - $1''$	8d common nail ($2\frac{1}{2}'' \times 0.131''$)	6	12^g
$1\frac{1}{8}''$ - $1\frac{1}{4}''$	10d common ($3'' \times 0.148''$) nail or 8d ($2\frac{1}{2}'' \times 0.131''$) deformed nail	6	12
Other wall sheathing^h			
$1/2''$ structural cellulosic fiberboard sheathing	$1\frac{1}{2}''$ galvanized roofing nail 8d common ($2\frac{1}{2}'' \times 0.131''$) nail; staple 16 ga., $1\frac{1}{2}''$ long	3	6
$25/32''$ structural cellulosic fiberboard sheathing	$1\frac{3}{4}''$ galvanized roofing nail 8d common ($2\frac{1}{2}'' \times 0.131''$) nail; staple 16 ga., $1\frac{3}{4}''$ long	3	6
$1/2''$ gypsum sheathing ^d	$1\frac{1}{2}''$ galvanized roofing nail; 6d common ($2'' \times 0.131''$) nail; staple galvanized $1\frac{1}{2}''$ long; $1\frac{1}{4}''$ screws, Type W or S	4	8
$5/8''$ gypsum sheathing ^d	$1\frac{3}{4}''$ galvanized roofing nail; 8d common ($2\frac{1}{2}'' \times 0.131''$) nail; staple galvanized $1\frac{5}{8}''$ long; $1\frac{5}{8}''$ screws, Type W or S	4	8
Wood structural panels, combination subfloor underlayment to framing			
$3/4''$ and less	6d deformed ($2'' \times 0.120''$) nail or 8d common ($2\frac{1}{2}'' \times 0.131''$) nail	6	12
$7/8''$ - $1''$	8d common ($2\frac{1}{2}'' \times 0.131''$) nail or 8d deformed ($2\frac{1}{2}'' \times 0.120''$) nail	6	12
$1\frac{1}{8}''$ - $1\frac{1}{4}''$	10d common ($3'' \times 0.148''$) nail or 8d deformed ($2\frac{1}{2}'' \times 0.120''$) nail	6	12

For SI: 1 inch = 25.4 mm, 1 foot = 304.8 mm, 1 mile per hour = 0.447 m/s; 1 ksi = 6.895 MPa.

- All nails are smooth-common, box or deformed shanks except where otherwise stated. Nails used for framing and sheathing connections shall have minimum average bending yield strengths as shown: 80 ksi for shank diameter of 0.192 inch (20d common nail), 90 ksi for shank diameters larger than 0.142 inch but not larger than 0.177 inch, and 100 ksi for shank diameters of 0.142 inch or less.
- Staples are 16 gage wire and have a minimum $7/16$ -inch on diameter crown width.
- Nails shall be spaced at not more than 6 inches on center at all supports where spans are 48 inches or greater.
- Four-foot-by-8-foot or 4-foot-by-9-foot panels shall be applied vertically.
- Spacing of fasteners not included in this table shall be based on Table R602.3(2).
- For regions having basic wind speed of 110 mph or greater, 8d deformed ($2\frac{1}{2}'' \times 0.120''$) nails shall be used for attaching plywood and wood structural panel roof sheathing to framing within minimum 48-inch distance from gable end walls, if mean roof height is more than 25 feet, up to 35 feet maximum.
- For regions having basic wind speed of 100 mph or less, nails for attaching wood structural panel roof sheathing to gable end wall framing shall be spaced 6 inches on center. When basic wind speed is greater than 100 mph, nails for attaching panel roof sheathing to intermediate supports shall be spaced 6 inches on center for minimum 48-inch distance from ridges, eaves and gable end walls; and 4 inches on center to gable end wall framing.
- Gypsum sheathing shall conform to ASTM C 79 and shall be installed in accordance with GA 253. Fiberboard sheathing shall conform to ASTM C 208.
- Spacing of fasteners on floor sheathing panel edges applies to panel edges supported by framing members and required blocking and at all floor perimeters only. Spacing of fasteners on roof sheathing panel edges applies to panel edges supported by framing members and required blocking. Blocking of roof or floor sheathing panel edges perpendicular to the framing members need not be provided except as required by other provisions of this code. Floor perimeter shall be supported by framing members or solid blocking.

TABLE R602.3(2)
ALTERNATE ATTACHMENTS

NOMINAL MATERIAL THICKNESS (inches)	DESCRIPTION ^{a,b} OF FASTENER AND LENGTH (inches)	SPACING ^c OF FASTENERS	
		Edges (inches)	Intermediate supports (inches)
Wood structural panels subfloor, roof and wall sheathing to framing and particleboard wall sheathing to framing^f			
up to 1/2	Staple 15 ga. 1 3/4	4	8
	0.097 - 0.099 Nail 2 1/4	3	6
19/32 and 5/8	Staple 16 ga. 1 3/4	3	6
	0.113 Nail 2	3	6
	Staple 15 and 16 ga. 2	4	8
23/32 and 3/4	0.097 - 0.099 Nail 2 1/4	4	8
	Staple 14 ga. 2	4	8
	Staple 15 ga. 1 3/4	3	6
	0.097 - 0.099 Nail 2 1/4	4	8
1	Staple 16 ga. 2	4	8
	Staple 14 ga. 2 1/4	4	8
	0.113 Nail 2 1/4	3	6
	Staple 15 ga. 2 1/4	4	8
	0.097 - 0.099 Nail 2 1/2	4	8
NOMINAL MATERIAL THICKNESS (inches)	DESCRIPTION ^{a,b} OF FASTENER AND LENGTH (inches)	SPACING ^c OF FASTENERS	
		Edges (inches)	Body of panel ^d (inches)
Floor underlayment; plywood-hardboard-particleboard^f			
Plywood			
1/4 and 5/16	1 1/4 ring or screw shank nail—minimum 12 1/2 ga. (0.099") shank diameter	3	6
	Staple 18 ga., 7/8, 3/16 crown width	2	5
11/32, 3/8, 15/32, 1/2 and 19/32	1 1/4 ring or screw shank nail—minimum 12 1/2 ga. (0.099") shank diameter	6	8 ^e
5/8, 23/32 and 3/4	1 1/2 ring or screw shank nail—minimum 12 1/2 ga. (0.099") shank diameter	6	8
	Staple 16 ga. 1 1/2	6	8
Hardboard^f			
0.200	1 1/2 long ring-grooved underlayment nail	6	6
	4d cement-coated sinker nail	6	6
	Staple 18 ga., 7/8 long (plastic coated)	3	6
Particleboard			
1/4	4d ring-grooved underlayment nail	3	6
	Staple 18 ga., 7/8 long, 3/16 crown	3	6
3/8	6d ring-grooved underlayment nail	6	10
	Staple 16 ga., 1 1/8 long, 3/8 crown	3	6
1/2, 5/8	6d ring-grooved underlayment nail	6	10
	Staple 16 ga., 1 5/8 long, 3/8 crown	3	6

For SI: 1 inch = 25.4 mm.

- a. Nail is a general description and may be T-head, modified round head or round head.
- b. Staples shall have a minimum crown width of 7/16-inch on diameter except as noted.
- c. Nails or staples shall be spaced at not more than 6 inches on center at all supports where spans are 48 inches or greater. Nails or staples shall be spaced at not more than 12 inches on center at intermediate supports for floors.
- d. Fasteners shall be placed in a grid pattern throughout the body of the panel.
- e. For 5-ply panels, intermediate nails shall be spaced not more than 12 inches on center each way.
- f. Hardboard underlayment shall conform to ANSI/AHA A135.4.

TABLE R602.3(3)
WOOD STRUCTURAL PANEL WALL SHEATHING

PANEL SPAN RATING	PANEL NOMINAL THICKNESS (inch)	MAXIMUM STUD SPACING (inches)	
		Siding nailed to: ^a	
		Stud	Sheathing
12/0, 16/0, 20/0, or wall—16 o.c.	$\frac{5}{16}$, $\frac{3}{8}$	16	16 ^b
24/0, 24/16, 32/16 or wall—24 o.c.	$\frac{3}{8}$, $\frac{7}{16}$, $\frac{15}{32}$, $\frac{1}{2}$	24	24 ^c

For SI: 1 inch = 25.4 mm.

- Blocking of horizontal joints shall not be required.
- Plywood sheathing $\frac{3}{8}$ -inch thick or less shall be applied with long dimension across studs.
- Three-ply plywood panels shall be applied with long dimension across studs.

TABLE R602.3(4)
ALLOWABLE SPANS FOR PARTICLEBOARD WALL SHEATHING^a

THICKNESS (inch)	GRADE	STUD SPACING (inches)	
		When siding is nailed to studs	When siding is nailed to sheathing
$\frac{3}{8}$	M-1 Exterior glue	16	—
$\frac{1}{2}$	M-2 Exterior glue	16	16

For SI: 1 inch = 25.4 mm.

- Wall sheathing not exposed to the weather. If the panels are applied horizontally, the end joints of the panel shall be offset so that four panels corners will not meet. All panel edges must be supported. Leave a $\frac{1}{16}$ -inch gap between panels and nail no closer than $\frac{3}{8}$ inch from panel edges.

TABLE R602.3(5)
SIZE, HEIGHT AND SPACING OF WOOD STUDS^a

STUD SIZE (inches)	BEARING WALLS					NONBEARING WALLS	
	Laterally unsupported stud height ^a (feet)	Maximum spacing when supporting roof and ceiling only (inches)	Maximum spacing when supporting one floor, roof and ceiling (inches)	Maximum spacing when supporting two floors, roof and ceiling (inches)	Maximum spacing when supporting one floor only (inches)	Laterally unsupported stud height ^a (feet)	Maximum spacing (inches)
2 × 3 ^b	—	—	—	—	—	10	16
2 × 4	10	24	16	—	24	14	24
3 × 4	10	24	24	16	24	14	24
2 × 5	10	24	24	—	24	16	24
2 × 6	10	24	24	16	24	20	24

For SI: 1 inch = 25.4 mm.

- Listed heights are distances between points of lateral support placed perpendicular to the plane of the wall. Increases in unsupported height are permitted where justified by analysis.
- Shall not be used in exterior walls.

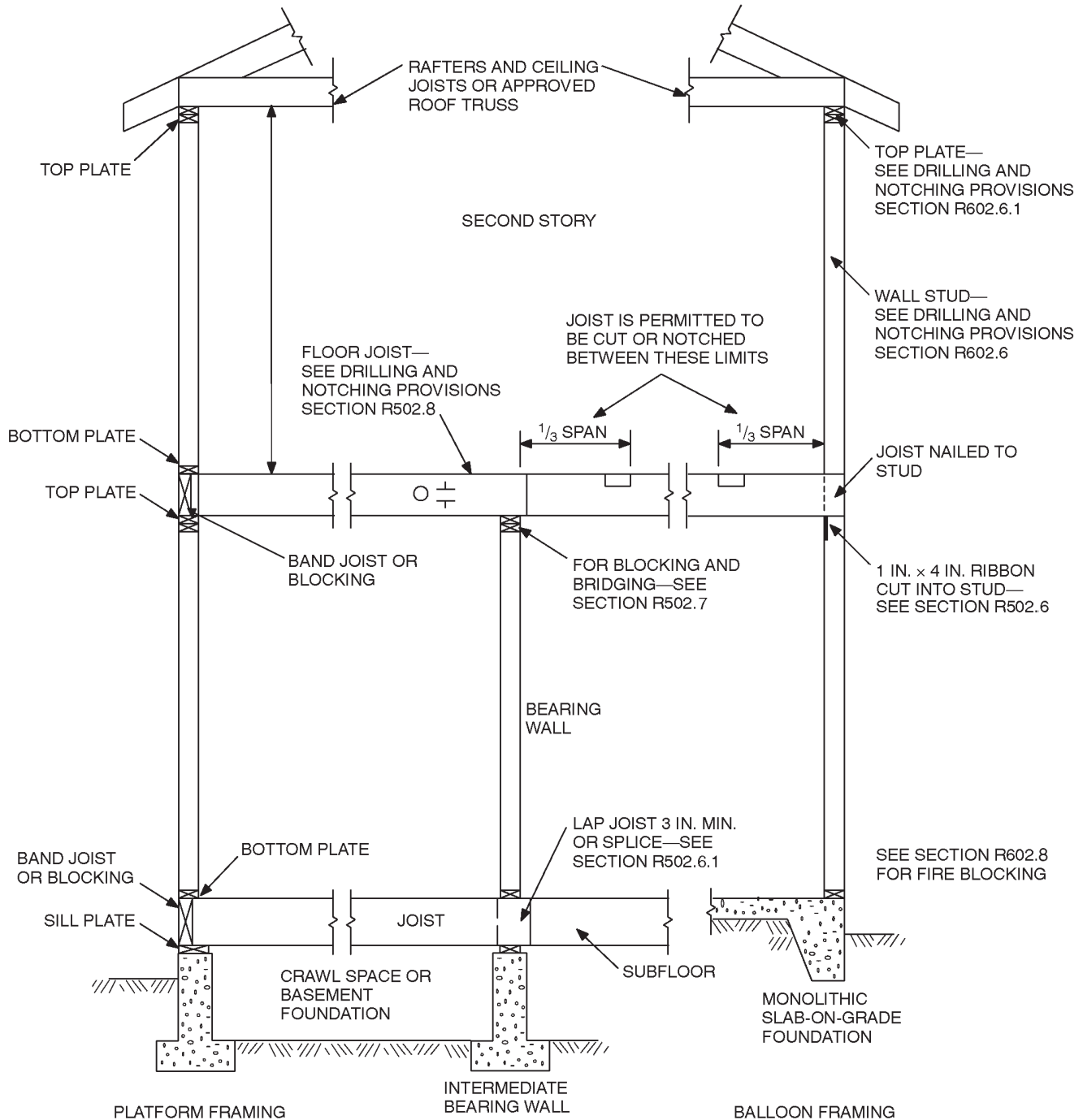

For SI: 1 inch = 25.4 mm.

FIGURE R602.3(1)
TYPICAL WALL, FLOOR AND ROOF FRAMING

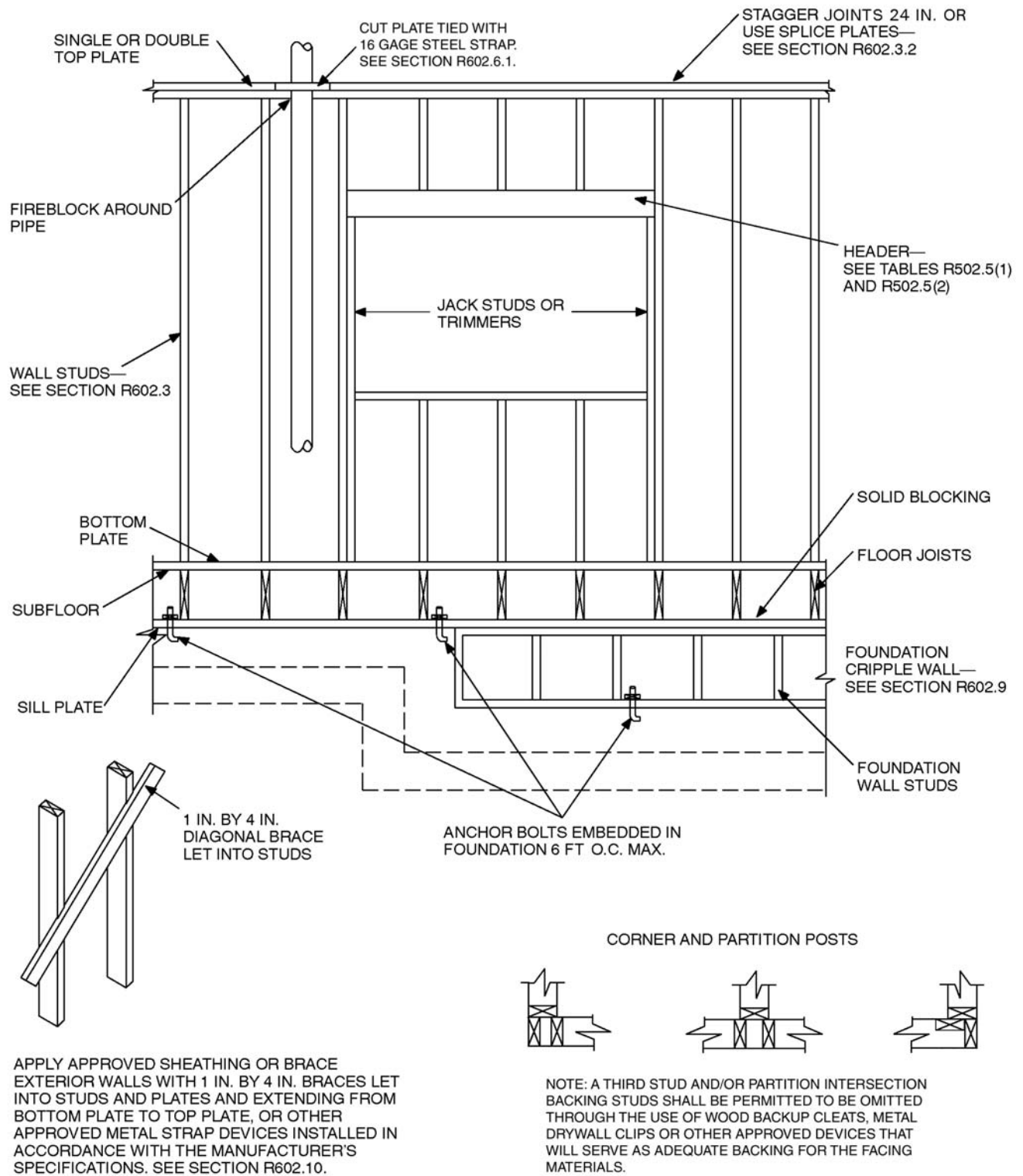

For SI: 1 inch = 25.4 mm, 1 foot = 304.8 mm.

FIGURE R602.3(2)
FRAMING DETAILS

TABLE R602.3.1
MAXIMUM ALLOWABLE LENGTH OF WOOD WALL STUDS EXPOSED TO WIND SPEEDS OF 100 mph OR LESS
IN SEISMIC DESIGN CATEGORIES A, B, C and D₀, D₁ AND D₂^{b, c}

HEIGHT (feet)	ON-CENTER SPACING (inches)			
	24	16	12	8
Supporting a roof only				
>10	2 × 4	2 × 4	2 × 4	2 × 4
12	2 × 6	2 × 4	2 × 4	2 × 4
14	2 × 6	2 × 6	2 × 6	2 × 4
16	2 × 6	2 × 6	2 × 6	2 × 4
18	NA ^a	2 × 6	2 × 6	2 × 6
20	NA ^a	NA ^a	2 × 6	2 × 6
24	NA ^a	NA ^a	NA ^a	2 × 6
Supporting one floor and a roof				
>10	2 × 6	2 × 4	2 × 4	2 × 4
12	2 × 6	2 × 6	2 × 6	2 × 4
14	2 × 6	2 × 6	2 × 6	2 × 6
16	NA ^a	2 × 6	2 × 6	2 × 6
18	NA ^a	2 × 6	2 × 6	2 × 6
20	NA ^a	NA ^a	2 × 6	2 × 6
24	NA ^a	NA ^a	NA ^a	2 × 6
Supporting two floors and a roof				
>10	2 × 6	2 × 6	2 × 4	2 × 4
12	2 × 6	2 × 6	2 × 6	2 × 6
14	2 × 6	2 × 6	2 × 6	2 × 6
16	NA ^a	NA ^a	2 × 6	2 × 6
18	NA ^a	NA ^a	2 × 6	2 × 6
20	NA ^a	NA ^a	NA ^a	2 × 6
22	NA ^a	NA ^a	NA ^a	NA ^a
24	NA ^a	NA ^a	NA ^a	NA ^a

For SI: 1 inch = 25.4 mm, 1 foot = 304.8 mm, 1 pound per square foot = 0.0479 kPa,
 1 pound per square inch = 6.895 kPa, 1 mile per hour = 0.447 m/s.

- a. Design required.
- b. Applicability of this table assumes the following: Snow load not exceeding 25 psf, f_b not less than 1310 psi determined by multiplying the AF&PA NDS tabular base design value by the repetitive use factor, and by the size factor for all species except southern pine, E not less than 1.6×10^6 psi, tributary dimensions for floors and roofs not exceeding 6 feet, maximum span for floors and roof not exceeding 12 feet, eaves not over 2 feet in dimension and exterior sheathing. Where the conditions are not within these parameters, design is required.
- c. Utility, standard, stud and No. 3 grade lumber of any species are not permitted.

(continued)

TABLE R602.3.1—continued
 MAXIMUM ALLOWABLE LENGTH OF WOOD WALL STUDS EXPOSED TO WIND SPEEDS OF 100 mph OR LESS
 IN SEISMIC DESIGN CATEGORIES A, B, C, D₀, D₁ and D₂

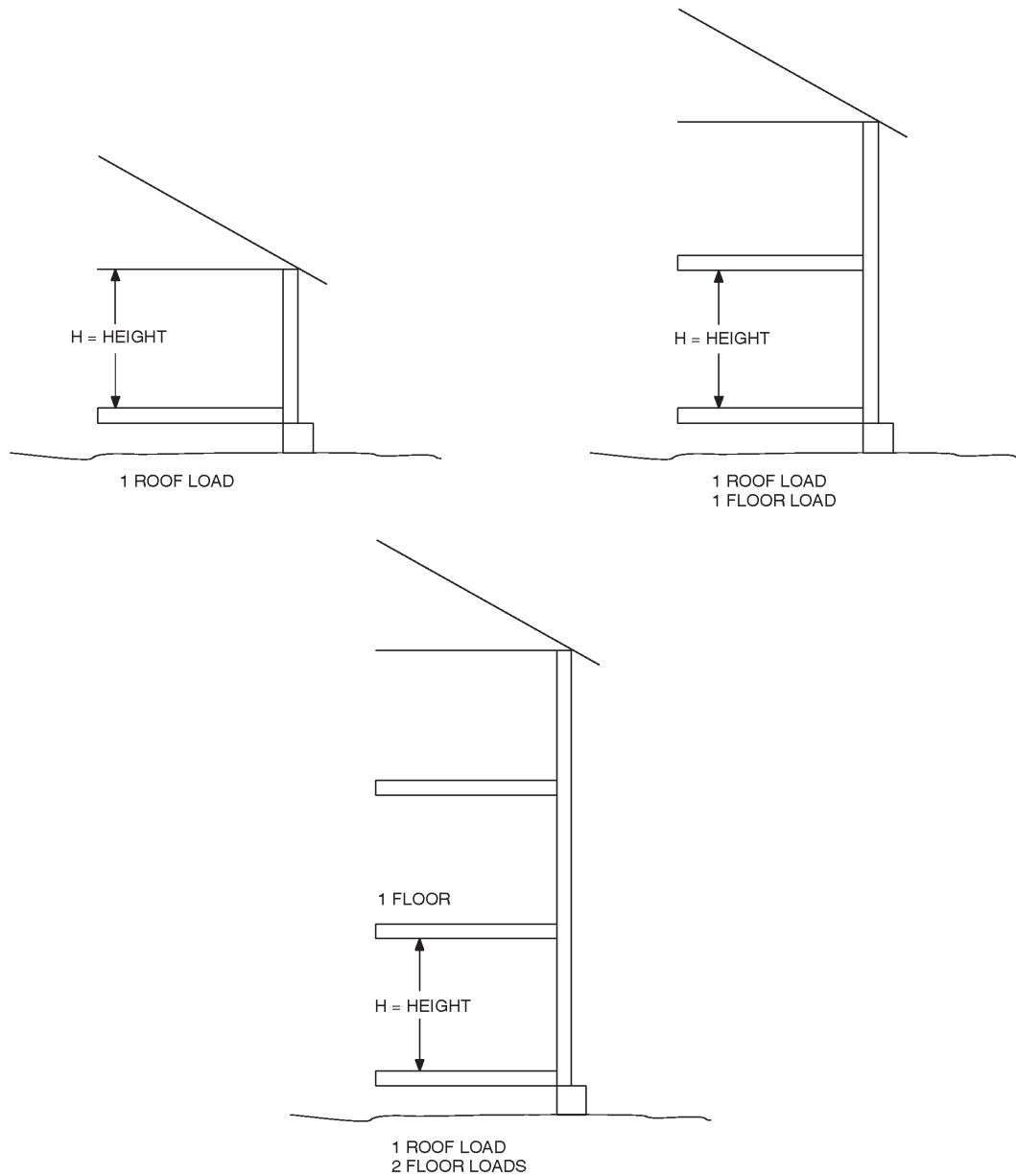

R602.3.4 Bottom (sole) plate. Studs shall have full bearing on a ((nominal)) 2-(by) inch nominal (38 mm) or larger plate or sill having a width at least equal to the width of the studs.

R602.4 Interior load-bearing walls. Interior load-bearing walls shall be constructed, framed and fireblocked as specified for exterior walls.

R602.5 Interior nonbearing walls. Interior nonbearing walls shall be permitted to be constructed with 2-inch-by-3-inch (51 mm by 76 mm) studs spaced 24 inches (610 mm) on center or, when not part of a braced wall line, 2-inch-by-4-inch (51 mm by 102 mm) flat studs spaced at 16 inches (406 mm) on center. Interior nonbearing walls shall be capped with at least a single top plate. Interior nonbearing walls shall be fireblocked in accordance with Section R602.8.

R602.6 Drilling and notching—studs. Drilling and notching of studs shall be in accordance with the following:

1. Notching. Any stud in an exterior wall or bearing partition may be cut or notched to a depth not exceeding 25 percent of its width. Studs in nonbearing partitions may be notched to a depth not to exceed 40 percent of a single stud width.
2. Drilling. Any stud may be bored or drilled, provided that the diameter of the resulting hole is no more than 60 percent of the stud width, the edge of the hole is no more than $\frac{5}{8}$ inch (16 mm) to the edge of the stud, and the hole is not located in the same section as a cut or notch. Studs located in exterior walls or bearing partitions drilled over 40 percent and up to 60 percent shall also be doubled with no more than two successive doubled studs bored. See Figures R602.6(1) and R602.6(2).

Exception: Use of approved stud shoes is permitted when they are installed in accordance with the manufacturer’s recommendations.

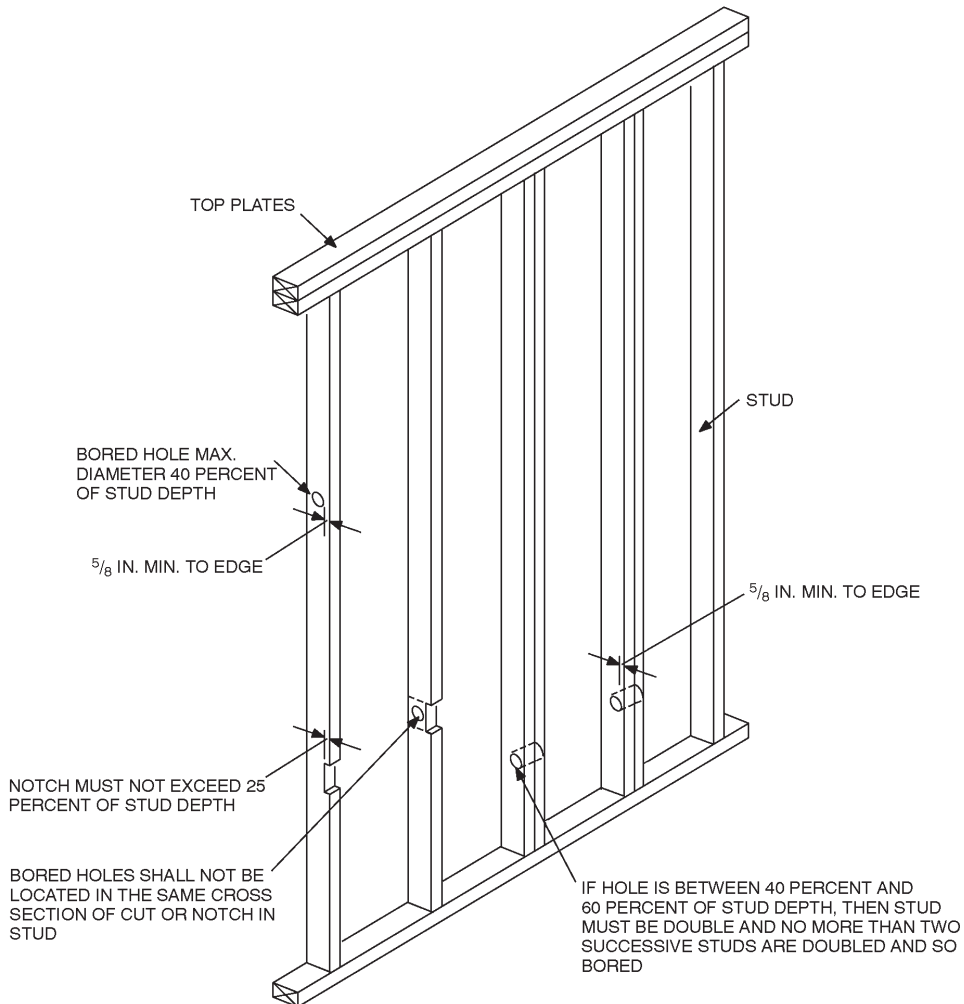

For SI: 1 inch = 25.4 mm.

NOTE: Condition for exterior and bearing walls.

FIGURE R602.6(1)
NOTCHING AND BORED HOLE LIMITATIONS FOR EXTERIOR WALLS AND BEARING WALLS

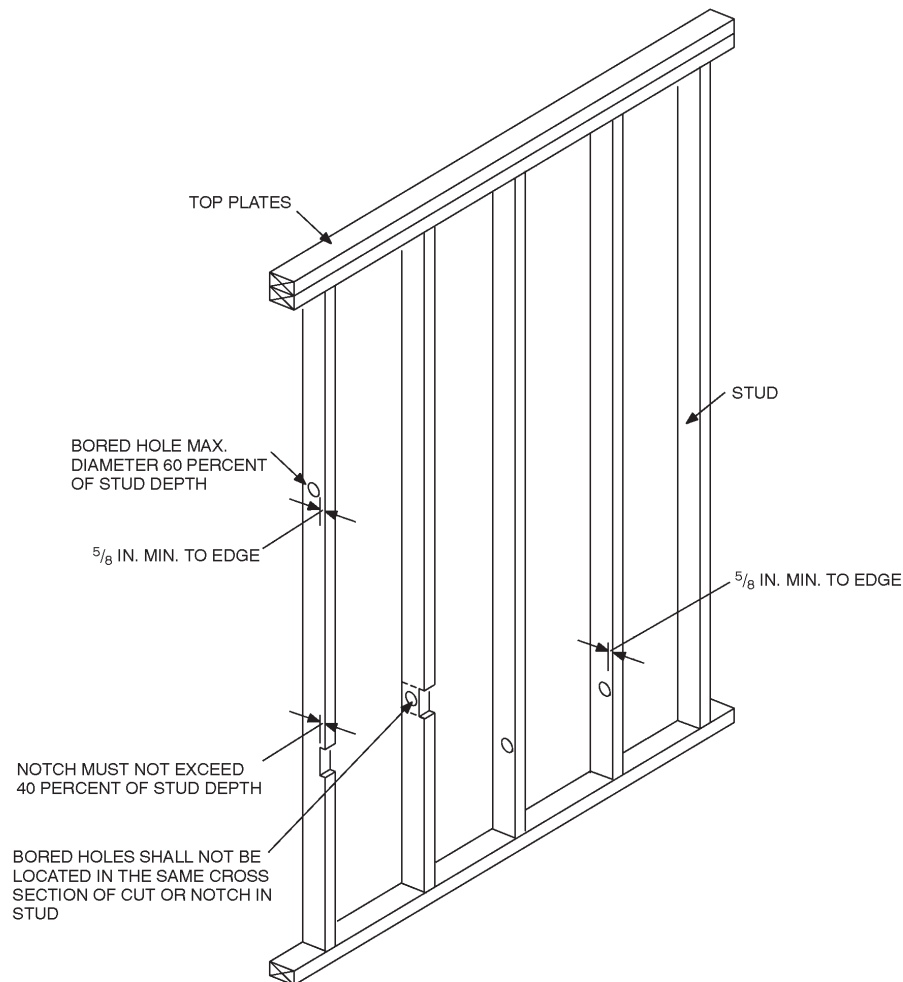

For SI: 1 inch = 25.4 mm.

FIGURE R602.6(2)
NOTCHING AND BORED HOLE LIMITATIONS FOR INTERIOR NONBEARING WALLS

R602.6.1 Drilling and notching of top plate. When piping or ductwork is placed in or partly in an exterior wall or interior load-bearing wall, necessitating cutting, drilling or notching of the top plate by more than 50 percent of its width, a galvanized metal tie of not less than 0.054 inch thick (1.37 mm) (16 ga) and 1 1/2 inches (38 mm) wide shall be fastened across and to the plate at each side of the opening with not less than eight 16d nails at each side or equivalent. See Figure R602.6.1.

Exception: When the entire side of the wall with the notch or cut is covered by wood structural panel sheathing.

R602.7 Headers. For header spans see Tables R502.5(1) and R502.5(2).

R602.7.1 Wood structural panel box headers. Wood structural panel box headers shall be constructed in accordance with Figure R602.7.2 and Table R602.7.2.

R602.7.2 Nonbearing walls. Load-bearing headers are not required in interior or exterior nonbearing walls. A single

flat 2-inch-by-4-inch (51 mm by 102 mm) member may be used as a header in interior or exterior nonbearing walls for openings up to 8 feet (2438 mm) in width if the vertical distance to the parallel nailing surface above is not more than 24 inches (610 mm). For such nonbearing headers, no cripples or blocking are required above the header.

R602.8 Fireblocking required. Fireblocking shall be provided to cut off all concealed draft openings (both vertical and horizontal) and to form an effective fire barrier between stories, and between a top story and the roof space. Fireblocking shall be provided in wood-frame construction in the following locations.

1. In concealed spaces of stud walls and partitions, including furred spaces and parallel rows of studs or staggered studs; as follows:
 - 1.1. Vertically at the ceiling and floor levels.
 - 1.2. Horizontally at intervals not exceeding 10 feet (3048 mm).

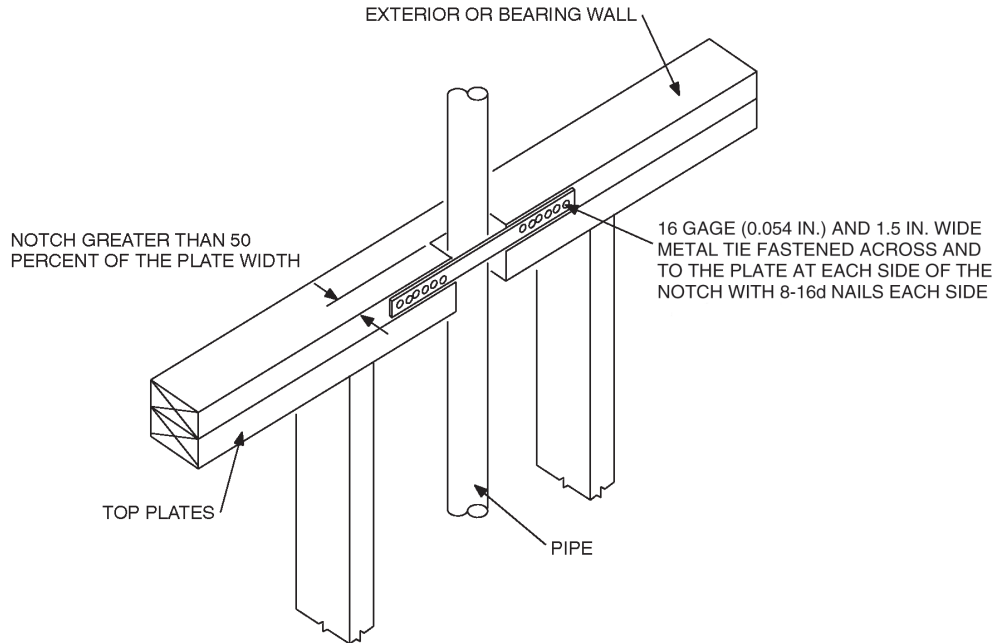

For SI: 1 inch = 25.4 mm.

FIGURE R602.6.1
TOP PLATE FRAMING TO ACCOMMODATE PIPING

2. At all interconnections between concealed vertical and horizontal spaces such as occur at soffits, drop ceilings and cove ceilings.
3. In concealed spaces between stair stringers at the top and bottom of the run. Enclosed spaces under stairs shall comply with Section R311.2.2.
4. At openings around vents, pipes, ducts, cables and wires at ceiling and floor level, with an approved material to resist the free passage of flame and products of combustion.
5. For the fireblocking of chimneys and fireplaces, see Section R1003.19.
6. Fireblocking of cornices of a two-family dwelling is required at the line of dwelling unit separation.

R602.8.1 Materials. Except as provided in Section R602.8, Item 4, fireblocking shall consist of 2-inch (51 mm) nominal lumber, or two thicknesses of 1-inch (25.4 mm) nominal lumber with broken lap joints, or one thickness of $2\frac{3}{32}$ -inch (19.8 mm) wood structural panels with joints backed by $2\frac{3}{32}$ -inch (19.8 mm) wood structural panels or one thickness of $\frac{3}{4}$ -inch (19.1 mm) particleboard with joints backed by $\frac{3}{4}$ -inch (19.1 mm) particleboard, $\frac{1}{2}$ -inch (12.7 mm) gypsum board, or $\frac{1}{4}$ -inch (6.4 mm) cement-based millboard. Batts or blankets of mineral wool or glass fiber or other approved materials installed in such a manner as to be securely retained in place shall be permitted as an acceptable fire block. Batts or blankets of mineral or glass fiber or other approved nonrigid materials shall be permitted for compliance with the 10 foot horizontal fireblocking in walls constructed using parallel rows of studs or staggered studs. Loose-fill insulation material shall not be used as a fire block unless specifically tested in the form and manner

intended for use to demonstrate its ability to remain in place and to retard the spread of fire and hot gases.

R602.8.1.1 Unfaced fiberglass. Unfaced fiberglass batt insulation used as fireblocking shall fill the entire cross section of the wall cavity to a minimum height of 16 inches (406 mm) measured vertically. When piping, conduit or similar obstructions are encountered, the insulation shall be packed tightly around the obstruction.

R602.8.1.2 Fireblocking integrity. The integrity of all fireblocks shall be maintained.

[W] R602.9 ((Cripple)) Foundation cripple walls. Foundation cripple walls shall be framed of studs not smaller than the studding above. When exceeding 4 feet (1219 mm) in height, such walls shall be framed of studs having the size required for an additional story.

Cripple walls supporting exterior walls or interior braced wall panels as required in Section R403.1.2 and R403.1.2.1 with a stud height less than 14 inches (356 mm) shall be sheathed on at least one side with a wood structural panel that is fastened to both the top and bottom plates in accordance with Table R602.3(1), or the cripple walls shall be constructed of solid blocking. Cripple walls supporting exterior walls or interior braced wall panels as required in Section R403.1.2 and R403.1.2.1 shall be supported on ((continuous)) foundations.

R602.10 Wall bracing. All exterior walls shall be braced in accordance with this section. In addition, interior braced wall lines shall be provided in accordance with Section R602.10.1.1. For buildings in Seismic Design Categories D₀, D₁ and D₂, walls shall be constructed in accordance with the additional requirements of Sections ((R602.10.9, R602.10.11, and R602.11)) R602.10.11 through R602.11.3.

**TABLE R602.7.2
MAXIMUM SPANS FOR WOOD STRUCTURAL PANEL BOX HEADERS^a**

HEADER CONSTRUCTION ^b	HEADER DEPTH (inches)	HOUSE DEPTH (feet)				
		24	26	28	30	32
Wood structural panel—one side	9	4	4	3	3	—
	15	5	5	4	3	3
Wood structural panel—both sides	9	7	5	5	4	3
	15	8	8	7	7	6

For SI: 1 inch = 25.4 mm, 1 foot = 304.8 mm.

- a. Spans are based on single story with clear-span trussed roof or two-story with floor and roof supported by interior-bearing walls.
- b. See Figure R602.7.2 for construction details.

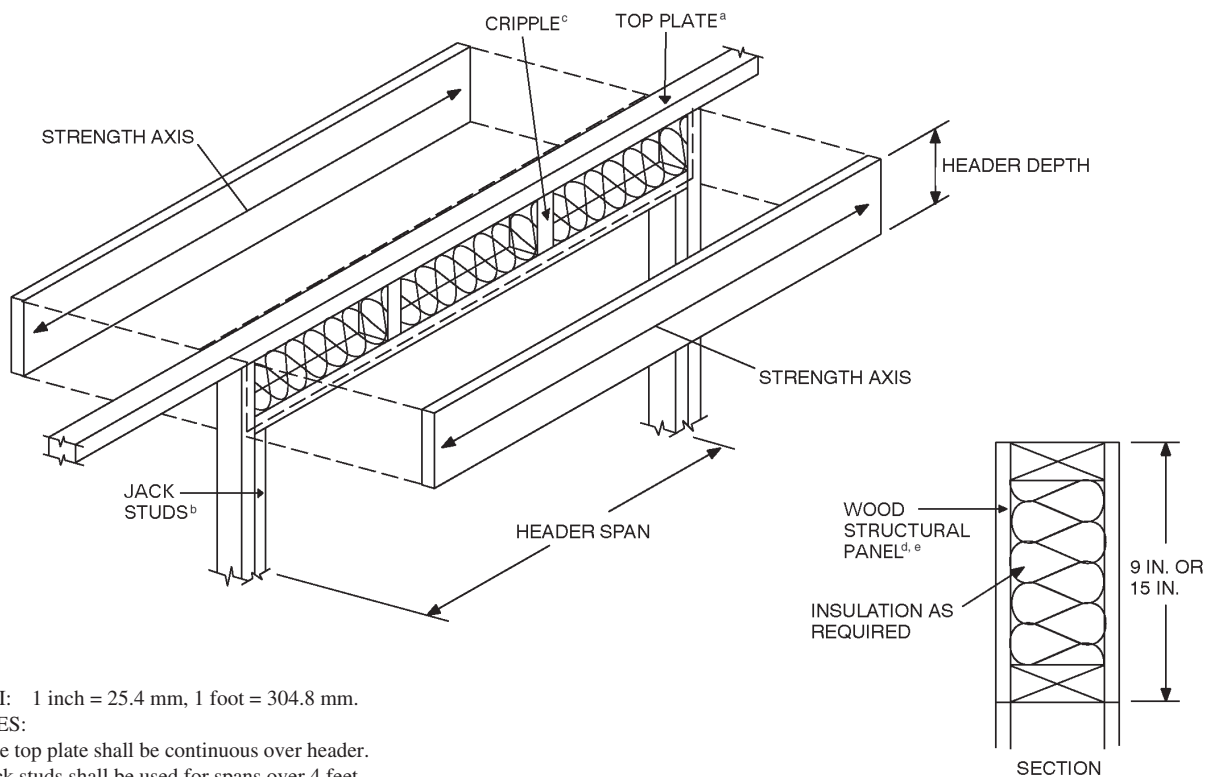

For SI: 1 inch = 25.4 mm, 1 foot = 304.8 mm.

NOTES:

- a. The top plate shall be continuous over header.
- b. Jack studs shall be used for spans over 4 feet.
- c. Cripple spacing shall be the same as for studs.
- d. Wood structural panel faces shall be single pieces of ¹⁵/₃₂-inch-thick Exposure 1 (exterior glue) or thicker, installed on the interior or exterior or both sides of the header.
- e. Wood structural panel faces shall be nailed to framing and cripples with 8d common or galvanized box nails spaced 3 inches on center, staggering alternate nails ¹/₂ inch. Galvanized nails shall be hot-dipped or tumbled.

**FIGURE R602.7.2
TYPICAL WOOD STRUCTURAL PANEL BOX HEADER CONSTRUCTION**

R602.10.1 Braced wall lines. Braced wall lines shall consist of braced wall panel construction in accordance with Section R602.10.3. The amount and location of bracing shall be in accordance with Table R602.10.1 and the amount of bracing shall be the greater of that required by the seismic design category or the design wind speed. Braced wall panels shall begin no more than 12.5 feet (3810 mm) from each end of a braced wall line. Braced wall panels that are counted as part of a braced wall line shall be in line, except that offsets out-of-plane of up to 4 feet (1219 mm) shall be permitted provided that the total out-to-out offset dimension in any braced wall line is not more than 8 feet (2438 mm).

R602.10.1.1 Spacing. Spacing of braced wall lines shall not exceed 35 feet (10 668 mm) on center in both the longitudinal and transverse directions in each story.

Exception: Spacing of braced wall lines not exceeding 50 feet shall be permitted where:

1. The wall bracing installed equals or exceeds the amount of bracing required by Table R602.10.1 multiplied by a factor equal to the braced wall line spacing divided by 35 feet and
2. The length-to-width ratio for the floor or roof diaphragm does not exceed 3:1.

R602.10.2 Cripple wall bracing.

R602.10.2.1 Seismic design categories other than D₂. In Seismic Design Categories other than D₂, cripple walls supporting exterior walls or interior braced wall panels as required in Sections R403.1.2 and R403.1.2.1 shall be braced with an amount and type of bracing as required for the wall above in accordance with Table R602.10.1 with the following modifications for cripple wall bracing:

1. The percent bracing amount as determined from Table R602.10.1 shall be increased by 15 percent and
2. The wall panel spacing shall be decreased to 18 feet (5486 mm) instead of 25 feet (7620 mm).

R602.10.2.2 Seismic Design Category D₂. In Seismic Design Category D₂, cripple walls supporting exterior walls or interior braced wall panels as required in Section R403.1.2 and R403.1.2.1 shall be braced in accordance with Table R602.10.1.

R602.10.2.3 Redesignation of cripple walls. In any seismic design category, cripple walls are permitted to be redesignated as the first story walls for purposes of determining wall bracing requirements. If the cripple walls are redesignated, the stories above the redesignated story shall be counted as the second and third stories, respectively.

R602.10.3 Braced wall panel construction methods. The construction of braced wall panels shall be in accordance with one of the following methods:

1. Nominal 1-inch-by-4-inch (25 mm by 102 mm) continuous diagonal braces let in to the top and bottom plates and the intervening studs or approved metal strap devices installed in accordance with the manu-

facturer's specifications. The let-in bracing shall be placed at an angle not more than 60 degrees (1.06 rad) or less than 45 degrees (0.79 rad) from the horizontal.

2. Wood boards of $\frac{5}{8}$ inch (16 mm) net minimum thickness applied diagonally on studs spaced a maximum of 24 inches (610 mm). Diagonal boards shall be attached to studs in accordance with Table R602.3(1).
3. Wood structural panel sheathing with a thickness not less than $\frac{5}{16}$ inch (8 mm) for 16-inch (406 mm) stud spacing and not less than $\frac{3}{8}$ inch (9 mm) for 24-inch (610 mm) stud spacing. Wood structural panels shall be installed in accordance with Table R602.3(3).
4. One-half-inch (13 mm) or $\frac{25}{32}$ -inch (20 mm) thick structural fiberboard sheathing applied vertically or horizontally on studs spaced a maximum of 16 inches (406 mm) on center. Structural fiberboard sheathing shall be installed in accordance with Table R602.3(1).
5. Gypsum board with minimum $\frac{1}{2}$ -inch (13 mm) thickness placed on studs spaced a maximum of 24 inches (610 mm) on center and fastened at 7 inches (178 mm) on center with the size nails specified in Table R602.3(1) for sheathing and Table R702.3.5 for interior gypsum board.
6. Particleboard wall sheathing panels installed in accordance with Table R602.3(4).
7. Portland cement plaster on studs spaced a maximum of 16 inches (406 mm) on center and installed in accordance with Section R703.6.
8. Hardboard panel siding when installed in accordance with Table R703.4.

Exception: Alternate braced wall panels constructed in accordance with Section R602.10.6.1 or R602.10.6.2 shall be permitted to replace any of the above methods of braced wall panels.

R602.10.4 Length of braced panels. For Methods 2, 3, 4, 6, 7 and 8 above, each braced wall panel shall be at least 48 inches (1219 mm) in length, covering a minimum of three stud spaces where studs are spaced 16 inches (406 mm) on center and covering a minimum of two stud spaces where studs are spaced 24 inches (610 mm) on center. For Method 5 above, each braced wall panel shall be at least 96 inches (2438 mm) in length where applied to one face of a braced wall panel and at least 48 inches (1219 mm) where applied to both faces.

Exceptions:

1. Lengths of braced wall panels for continuous wood structural panel sheathing shall be in accordance with Section R602.10.5.
2. Lengths of alternate braced wall panels shall be in accordance with Section R602.10.6.1 or Section R602.10.6.2.

R602.10.5 Continuous wood structural panel sheathing. When continuous wood structural panel sheathing is provided in accordance with Method 3 of Section R602.10.3 on all sheathable areas of all exterior walls, ((and interior

**TABLE R602.10.1
WALL BRACING**

SEISMIC DESIGN CATEGORY OR WIND SPEED	CONDITION	TYPE OF BRACE ^{b, c}	AMOUNT OF BRACING ^{a, d, e}
Category A and B ($S_s \leq 0.35g$ and $S_{ds} \leq 0.33g$) or 100 mph or less	One story Top of two or three story	Methods 1, 2, 3, 4, 5, 6, 7 or 8	Located in accordance with Section R602.10 and at least every 25 feet on center but not less than 16% of braced wall line for Methods 2 through 8.
	First story of two story Second story of three story	Methods 1, 2, 3, 4, 5, 6, 7 or 8	Located in accordance with Section R602.10 and at least every 25 feet on center but not less than 16% of braced wall line for Method 3 or 25% of braced wall line for Methods 2, 4, 5, 6, 7 or 8.
	First story of three story	Methods 2, 3, 4, 5, 6, 7 or 8	Located in accordance with Section R602.10 and at least every 25 feet on center but not less than 25% of braced wall line for Method 3 or 35% of braced wall line for Methods 2, 4, 5, 6, 7 or 8.
Category C ($S_s \leq 0.6g$ and $S_{ds} \leq 0.50g$) or less than 110 mph	One story Top of two or three story	Methods 1, 2, 3, 4, 5, 6, 7 or 8	Located in accordance with Section R602.10 and at least every 25 feet on center but not less than 16% of braced wall line for Method 3 or 25% of braced wall line for Methods 2, 4, 5, 6, 7 or 8.
	First story of two story Second story of three story	Methods 2, 3, 4, 5, 6, 7 or 8	Located in accordance with Section R602.10 and at least every 25 feet on center but not less than 30% of braced wall line for Method 3 or 45% of braced wall line for Methods 2, 4, 5, 6, 7 or 8.
	First story of three story	Methods 2, 3, 4, 5, 6, 7 or 8	Located in accordance with Section R602.10 and at least every 25 feet on center but not less than 45% of braced wall line for Method 3 or 60% of braced wall line for Methods 2, 4, 5, 6, 7 or 8.
Categories D ₀ and D ₁ ($S_s \leq 1.25g$ and $S_{ds} \leq 0.83g$) or less than 110 mph	One story Top of two or three story	Methods 2, 3, 4, 5, 6, 7 or 8	Located in accordance with Section R602.10 and at least every 25 feet on center but not less than 20% of braced wall line for Method 3 or 30% of braced wall line for Methods 2, 4, 5, 6, 7 or 8.
	First story of two story Second story of three story	Methods 2, 3, 4, 5, 6, 7 or 8	Located in accordance with Section R602.10 and at least every 25 feet on center but not less than 45% of braced wall line for Method 3 or 60% of braced wall line for Methods 2, 4, 5, 6, 7 or 8.
	First story of three story	Methods 2, 3, 4, 5, 6, 7 or 8	Located in accordance with Section R602.10 and at least every 25 feet on center but not less than 60% of braced wall line for Method 3 or 85% of braced wall line for Methods 2, 4, 5, 6, 7 or 8.
Category D ₂ or less than 110 mph	One story Top of two story	Methods 2, 3, 4, 5, 6, 7 or 8	Located in accordance with Section R602.10 and at least every 25 feet on center but not less than 25% of braced wall line for Method 3 or 40% of braced wall line for Methods 2, 4, 5, 6, 7 or 8.
	First story of two story	Methods 2, 3, 4, 5, 6, 7 or 8	Located in accordance with Section R602.10 and at least every 25 feet on center but not less than 55% of braced wall line for Method 3 or 75% of braced wall line for Methods 2, 4, 5, 6, 7 or 8.
	Cripple walls	Method 3	Located in accordance with Section R602.10 and at least every 25 feet on center but not less than 75% of braced wall line.

For SI: 1 inch = 25.4 mm, 1 foot = 304.8 mm, 1 pound per square foot = 0.0479 kPa, 1 mile per hour = 0.477 m/s.

- a. Wall bracing amounts are based on a soil site class "D." Interpolation of bracing amounts between the S_{ds} values associated with the seismic design categories shall be permitted when a site specific S_{ds} value is determined in accordance with Section 1613.5 of the *International Building Code*.
- b. Foundation cripple wall panels shall be braced in accordance with Section R602.10.2.
- c. Methods of bracing shall be as described in Section R602.10.3. The alternate braced wall panels described in Section R602.10.6.1 or R602.10.6.2 shall also be permitted.
- d. The bracing amounts for Seismic Design Categories are based on a 15 psf wall dead load. For walls with a dead load of 8 psf or less, the bracing amounts shall be permitted to be multiplied by 0.85 provided that the adjusted bracing amount is not less than that required for the site's wind speed. The minimum length of braced panel shall not be less than required by Section R602.10.3.
- e. When the dead load of the roof/ceiling exceeds 15 psf, the bracing amounts shall be increased in accordance with Section R301.2.2.2.1. Bracing required for a site's wind speed shall not be adjusted.

~~braced wall lines, where required;)) including areas above and below openings, bracing wall panel lengths ((shall be)) are not required to comply with Section R602.10.4 provided they are in accordance with Table R602.10.5. Wood structural panel sheathing shall be installed at corners in accordance with Figure R602.10.5. The bracing ((amounts)) percentages in Table R602.10.1 for Method 3 shall be permitted to be multiplied by a factor of 0.9 for exterior walls with a maximum opening height that does not exceed 85 percent of the wall height or a factor of 0.8 for exterior walls with a maximum opening height that does not exceed 67 percent of the wall height.~~

R602.10.6 Alternate braced wall panel construction methods. Alternate braced wall panels shall be constructed in accordance with Sections R602.10.6.1 and R602.10.6.2.

R602.10.6.1 Alternate braced wall panels. Alternate braced wall ((lines)) panels constructed in accordance with one of the following provisions shall be permitted to replace each 4 feet (1219 mm) of braced wall panel as required by Section R602.10.4. The maximum height and minimum width of each panel shall be in accordance with Table R602.10.6:

1. In one-story buildings, each panel shall be sheathed on one face with ³/₈-inch-minimum-thickness (10 mm) wood structural panel sheathing nailed with 8d common or galvanized box nails in accordance with Table R602.3(1) and blocked at all wood structural panel sheathing edges. Two anchor bolts installed in accordance with Figure R403.1(1) shall be provided in each panel. Anchor bolts shall be placed ~~((at panel quarter points)) in from each end of the panel a horizontal distance of one-fourth the panel width.~~ Each panel end stud shall have a tie-down device fastened to the foundation, capable of providing an uplift capacity in accordance with Table R602.10.6. The tie down device shall be installed in accordance with the manufacturer’s recommendations. The panels shall be supported directly on a foundation or on floor framing supported directly

on a foundation which is continuous across the entire length of the braced wall line. This foundation shall be reinforced with not less than one No. 4 bar top and bottom. When the continuous foundation is required to have a depth greater than 12 inches (305 mm), a minimum 12-inch-by-12-inch (305 mm by 305 mm) continuous footing or turned down slab edge is permitted at door openings in the braced wall line. This continuous footing or turned down slab edge shall be reinforced with not less than one No. 4 bar top and bottom. This reinforcement shall be lapped 15 inches (381 mm) with the reinforcement required in the continuous foundation located directly under the braced wall line.

2. In the first story of two-story buildings, each braced wall panel shall be in accordance with Item 1 above, except that ((the)):

2.1. The wood structural panel sheathing shall be ((installed)) provided on both faces,

2.2 ((s)) Sheathing edge nailing spacing shall not exceed 4 inches (102 mm) on center, and, ((at least three anchor bolts shall be placed at one-fifth points.))

2.3. Anchor bolts shall be placed at the center of the panel width and in from each end of the panel a horizontal distance of one-fifth the panel width (three total).

R602.10.6.2 Alternate braced wall panel adjacent to a door or window opening. Alternate braced wall panels constructed in accordance with one of the following provisions are also permitted to replace each 4 feet (1219 mm) of braced wall panel as required by Section R602.10.4 for use adjacent to a window or door opening with a full-length header:

1. In one-story buildings, each panel shall have a length of not less than 16 inches (406 mm) and a height of not more than 10 feet (3048 mm). Each panel shall be sheathed on one face with a single layer of ³/₈-inch-minimum-thickness (10 mm)

TABLE R602.10.5
LENGTH REQUIREMENTS FOR BRACED WALL PANELS IN A CONTINUOUSLY SHEATHED WALL^{a, b, c}

MINIMUM LENGTH OF BRACED WALL PANEL (inches)			MAXIMUM OPENING HEIGHT NEXT TO THE BRACED WALL PANEL (% of wall height)
8-foot wall	9-foot wall	10-foot wall	
48	54	60	100
32	36	40	85
24	27	30	65

For SI: 1 inch = 25.4 mm, 1 foot = 305 mm, 1 pound per square foot = 0.0479 kPa.

- a. Linear interpolation shall be permitted.
- b. Full-height sheathed wall segments to either side of garage openings that support ((light frame)) roofs of light-framed construction only, with roof covering dead loads of 3 psf or less shall be permitted to have a 4:1 ((aspeet)) height-to-width ratio.
- c. Walls on either or both sides of openings in garages attached to fully sheathed dwellings shall be permitted to be built in accordance with Section R602.10.6.2 and Figure R602.10.6.2 except that a single ((bottom)) sill plate shall be permitted and two anchor bolts shall be placed at 1/3 points. In addition, tie-down devices shall not be required and the vertical wall segment shall have a maximum 6:1 height-to-width ratio (with height being measured from top of header to the bottom of the sill plate). This option shall be permitted for the first story of two-story applications in Seismic Design Categories A through C.

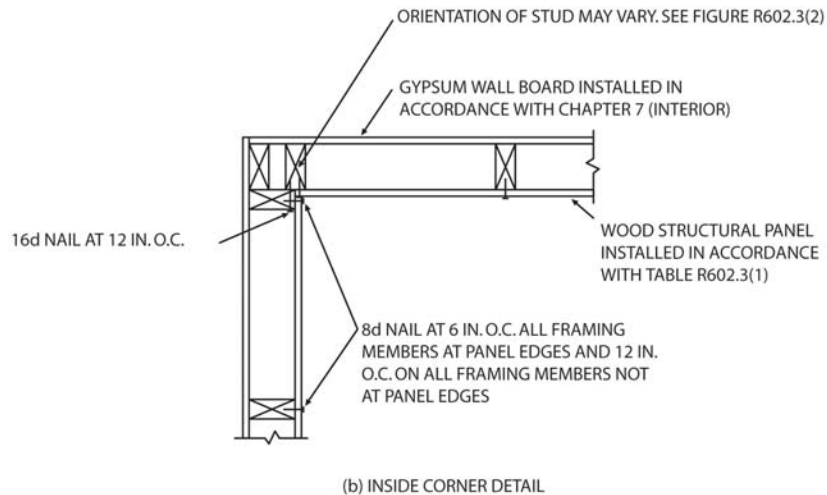
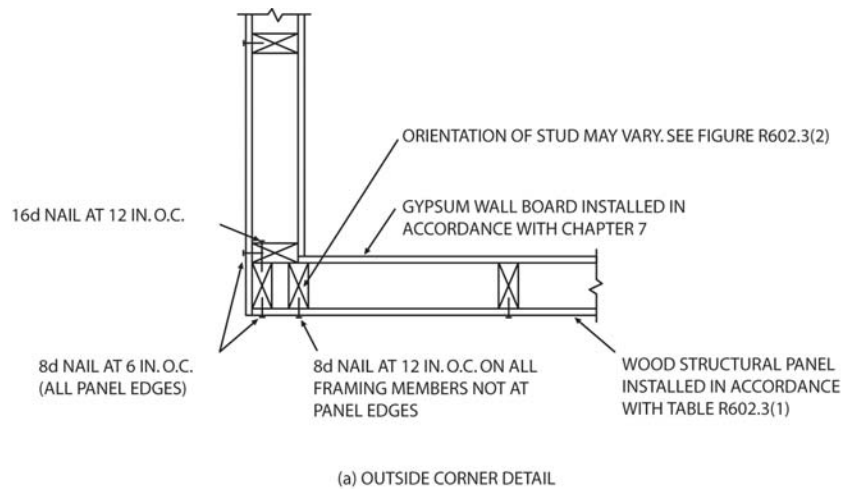

For SI: 1 inch = 25.4 mm.
Gypsum board nails deleted for clarity.

FIGURE R602.10.5
TYPICAL EXTERIOR CORNER FRAMING FOR CONTINUOUS STRUCTURAL
PANEL SHEATHING; SHOWING REQUIRED STUD-TO-STUD NAILING

wood structural panel sheathing nailed with 8d common or galvanized box nails in accordance with Figure R602.10.6.2. The wood structural panel sheathing shall extend up over the solid sawn or glued-laminated header and shall be nailed in accordance with Figure R602.10.6.2. Use of a built-up header consisting of at least two 2 x 12s and fastened in accordance with Table R602.3(1) shall be permitted. A spacer, if used, shall be placed on the side of the built-up beam opposite the wood structural panel sheathing. The header shall extend between the inside faces of the first full-length outer studs of each panel. The clear span of the header between the inner studs of each panel shall be not less than 6 feet (1829 mm) and not more than 18 feet (5486 mm) in length. A strap

with an uplift capacity of not less than 1000 pounds (4448 N) shall fasten the header to the side of the inner studs opposite the sheathing. One anchor bolt not less than $\frac{5}{8}$ -inch-diameter (16 mm) and installed in accordance with Section R403.1.6 shall be installed in the center of each sill plate. The studs at each end of the panel shall have a tie-down device fastened to the foundation with an uplift capacity of not less than 4,200 pounds (18 683 N).

Where a panel is located on one side of the opening, the header shall extend between the inside face of the first full-length stud of the panel and the bearing studs at the other end of the opening. A strap with an uplift capacity of not less than 1000 pounds (4448 N) shall fasten the header to the bearing

TABLE R602.10.6
MINIMUM WIDTHS AND TIE-DOWN FORCES OF ALTERNATE BRACED WALL PANELS

SEISMIC DESIGN CATEGORY AND WINDSPEED	TIE-DOWN FORCE (lb)	HEIGHT OF BRACED WALL PANEL				
		Sheathed Width				
		8 ft. 2' - 4"	9 ft. 2' - 8"	10 ft. 2' - 8"	11 ft. 3' - 2"	12 ft. 3' - 6"
SDC A, B, and C Windspeed < 110 mph	R602.10.6.1, Item 1	1800	1800	1800	2000	2200
	R602.10.6.1, Item 2	3000	3000	3000	3300	3600
SDC D ₀ , D ₁ and D ₂ Windspeed < 110 mph	R602.10.6.1, Item 1	Sheathed Width				
		2' - 8"	2' - 8"	2' - 8"	Note a	Note a
	R602.10.6.1, Item 2	1800	1800	1800	—	—
	R602.10.6.1, Item 2	3000	3000	3000	—	—

For SI: 1 inch = 25.4 mm, 1 foot = 304.8 mm.

a. Not permitted because maximum height is 10 feet.

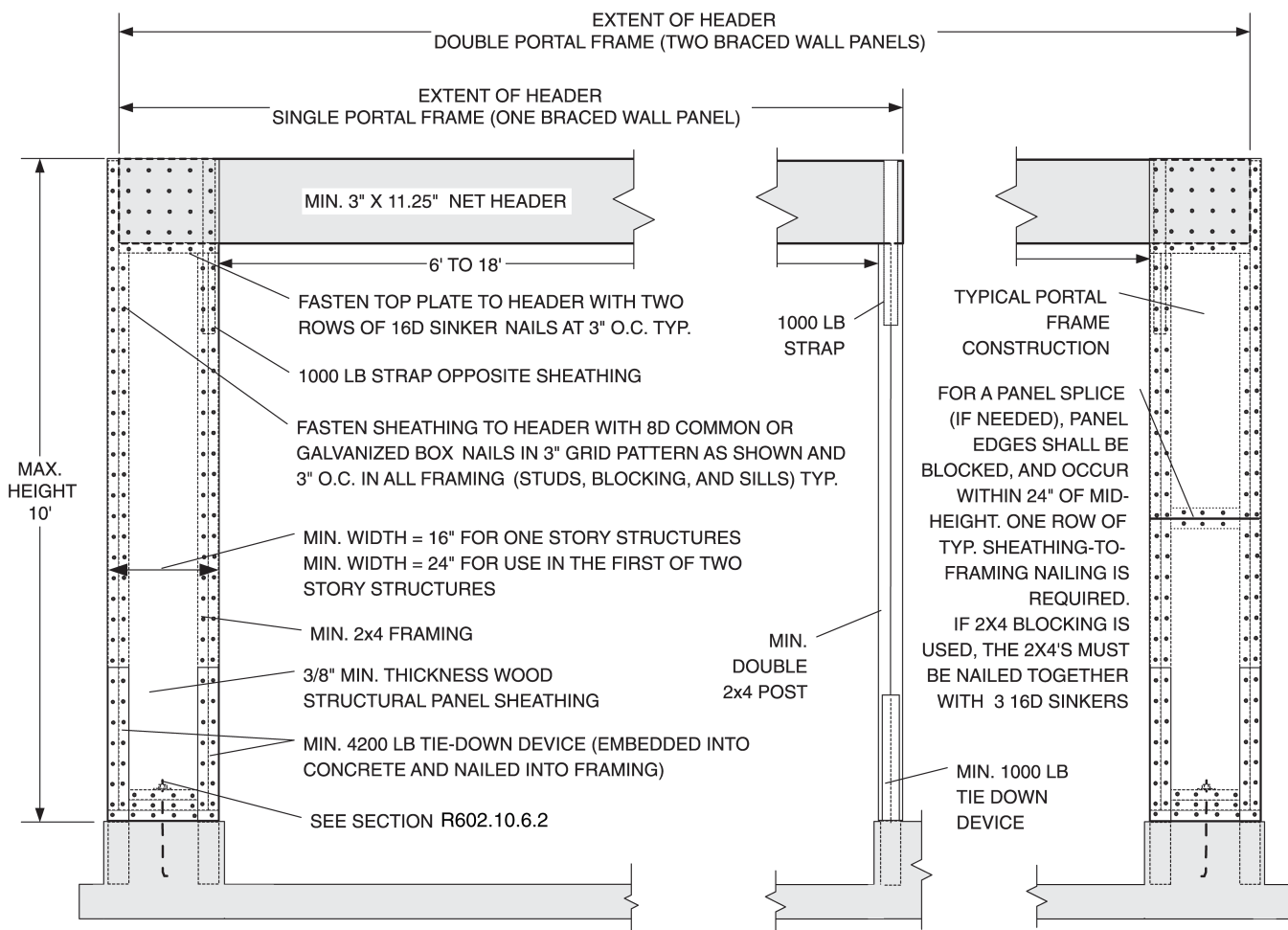

For SI: 1 inch = 25.4 mm, 1 foot = 304.8 mm, 1 pound = 0.454 kg.

FIGURE R602.10.6.2
ALTERNATE BRACED WALL PANEL ADJACENT TO A DOOR OR WINDOW OPENING

studs. The bearing studs shall also have a tie-down device fastened to the foundation with an uplift capacity of not less than 1000 pounds (4448 N).

The tie-down devices shall be an embedded-strap type, installed in accordance with the manufacturer's recommendations. The panels shall be supported directly on a foundation which is continuous across the entire length of the braced wall line. The foundation shall be reinforced with not less than one No. 4 bar top and bottom.

Where the continuous foundation is required to have a depth greater than 12 inches (305 mm), a minimum 12-inch-by-12-inch (305 mm by 305 mm) continuous footing or turned down slab edge is permitted at door openings in the braced wall line. This continuous footing or turned down slab edge shall be reinforced with not less than one No. 4 bar top and bottom. This reinforcement shall be lapped not less than 15 inches (381 mm) with the reinforcement required in the continuous foundation located directly under the braced wall line.

2. In the first story of two-story buildings, each wall panel shall be braced in accordance with Item 1 above, except that each panel shall have a length of not less than 24 inches (610 mm).

R602.10.7 Panel joints. All vertical joints of panel sheathing shall occur over, and be fastened to, common studs. Horizontal joints in braced wall panels shall occur over, and be fastened to, common blocking of a minimum ~~((1 1/2-inch (38 mm)))~~ **2 inches (51 mm) in nominal thickness.**

Exception: Blocking is not required behind horizontal joints in Seismic Design Categories A and B and detached dwellings in Seismic Design Category C when constructed in accordance with Section R602.10.3, braced-wall-panel construction method 3 and Table R602.10.1, method 3, or where permitted by the manufacturer's installation requirements for the specific sheathing material.

R602.10.8 Connections. Braced wall ~~((line))~~ **panel bottom** (sole) plates shall be fastened to the floor framing and top plates shall be connected to the framing above in accordance with Table R602.3(1). ~~((Sills))~~ **Sill plates** shall be fastened to the **footing**, foundation or slab in accordance with Sections R403.1.6 and R602.11. Where joists are perpendicular to the braced wall lines above, blocking shall be provided under and in line with the braced wall panels. Where joists are perpendicular to braced wall lines below, blocking shall be provided over and in line with the braced wall panels. Where joists are parallel to braced wall lines above or below, a rim joist or other parallel framing member shall be provided at the wall to permit fastening per Table R602.3(1). **For buildings in Seismic Design Categories D₀, D₁ and D₂, braced wall panels shall also be fastened in accordance with Section R602.11.2.**

R602.10.9 Interior braced wall support. ~~This section is not adopted. See Section R403.1.2. ((In one-story buildings located in Seismic Design Category D₂, interior braced wall lines shall be supported on continuous foundations at intervals not exceeding 50 feet (15 240 mm). In two-story buildings~~

~~located in Seismic Design Category D₂, all interior braced wall panels shall be supported on continuous foundations.~~

Exception: Two-story buildings shall be permitted to have interior braced wall lines supported on continuous foundations at intervals not exceeding 50 feet (15 240 mm) provided that:

1. The height of cripple walls does not exceed 4 feet (1219 mm);
2. First-floor braced wall panels are supported on doubled floor joists, continuous blocking or floor beams;
3. The distance between bracing lines does not exceed twice the building width measured parallel to the braced wall line.)

R602.10.10 Design of structural elements. Where a building, or portion thereof, does not comply with one or more of the bracing requirements in ~~((this section,))~~ **Sections R602.10 through R602.10.9**, those portions shall be designed and constructed in accordance with accepted engineering practice.

R602.10.11 Bracing in Seismic Design Categories D₀, D₁ and D₂. Structures located in Seismic Design Categories D₀, D₁ and D₂ shall ~~((have))~~ **be provided with** exterior and interior braced wall lines.

R602.10.11.1 Braced wall line spacing. Spacing between braced wall lines in each story shall not exceed 25 feet (7620 mm) on center in both the longitudinal and transverse directions.

Exception: In one- and two-story buildings, ~~((spacing between))~~ two adjacent braced wall lines shall not exceed 35 feet (10 663 mm) on center in order to accommodate ~~((one single room))~~ **an area** not exceeding 900 square feet (84 m²) in each dwelling unit. Spacing between all other braced wall lines shall not exceed 25 feet (7620 mm).

R602.10.11.2 Braced wall panel location. Exterior braced wall lines shall have a braced wall panel **located** at each end of the braced wall line.

Exception: For braced wall panel construction Method 3 of Section R602.10.3, the braced wall panel shall be permitted to begin no more than 8 feet (2438 mm) from each end of the braced wall line provided the following is satisfied:

1. A minimum 24-inch-wide (610 mm) panel is applied to each side of the building corner and the two 24-inch-wide (610 mm) panels at the corner shall be attached to framing in accordance with Figure R602.10.5; or
2. The end of each braced wall panel closest to the corner shall have a tie-down device fastened to the stud at the edge of the braced wall panel closest to the corner and to the foundation or framing below. The tie-down device shall be capable of providing an uplift allowable design value of at least 1,800 pounds (8 kN). The tie-down device shall be installed in accordance with the manufacturer's recommendations.

R602.10.11.3 Collectors. A designed collector shall be provided if a braced wall panel is not located at each end of a braced wall line as indicated in Section R602.10.11.2, or, when using the Section R602.10.11.2 exception, if a braced wall panel is more than 8 feet (2438 mm) from each end of a braced wall line.

R602.10.11.4 Cripple wall bracing. In addition to the requirements of Section R602.10.2, where interior braced wall panels occur without a continuous foundation below, the length of parallel exterior cripple wall bracing shall be one and one-half times the length required by Table R602.10.1. Where cripple walls braced using Method 3 of Section R602.10.3 cannot provide this additional length, the capacity of the sheathing shall be increased by reducing the spacing of fasteners along the perimeter of each piece of sheathing to 4 inches (102 mm) on center.

R602.10.11.5 Sheathing attachment. Adhesive attachment of wall sheathing shall not be permitted in Seismic Design Categories C, D₀, D₁ and D₂.

R602.11 Framing and connections for Seismic Design Categories D₀, D₁ and D₂. The framing and connections details of buildings located in Seismic Design Categories D₀, D₁ and D₂ shall be in accordance with Sections R602.11.1 through R602.11.3.

R602.11.1 Wall anchorage. Braced wall line sills shall be anchored to concrete or masonry foundations in accordance with Sections R403.1.6 and R602.11. For all buildings in Seismic Design Categories D₀, D₁ and D₂ and townhouses in Seismic Design Category C, plate washers, a

minimum of 0.229 inch by 3 inches by 3 inches (5.8 mm by 76 mm by 76 mm) in size, shall be installed between the foundation sill plate and the nut. The hole in the plate washer is permitted to be diagonally slotted with a width of up to 3/16 inch (5 mm) larger than the bolt diameter and a slot length not to exceed 1 3/4 inches (44 mm), provided a standard cut washer is placed between the plate washer and the nut.

R602.11.2 Interior braced wall panel connections. Interior braced wall panels shall be fastened to floor and roof framing in accordance with Table R602.3(1), to required foundations in accordance with Section R602.11.1, and in accordance with the following requirements:

1. Floor joists parallel to the top plate shall be toe-nailed to the top plate with at least 8d nails spaced a maximum of 6 inches (152 mm) on center.
2. Top plate laps shall be face-nailed with at least eight 16d nails on each side of the splice.

R602.11.3 Stepped foundations. Where stepped foundations occur, the following requirements apply:

1. Where the height of a required braced wall panel that extends from foundation to floor above varies more than 4 feet (1220 mm), the braced wall panel shall be constructed in accordance with Figure R602.11.3.
2. Where the lowest floor framing rests directly on a sill bolted to a foundation not less than 8 feet (2440 mm) in length along a line of bracing, the line shall be considered as braced. The double plate of the cripple stud

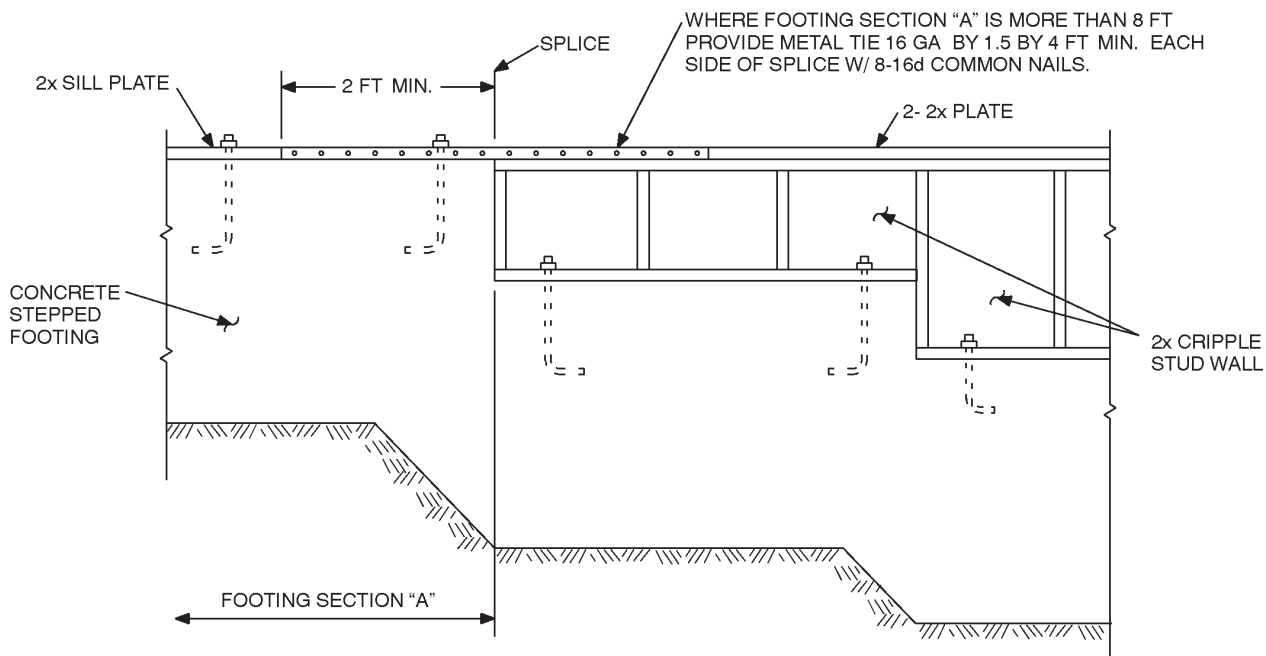

For SI: 1 inch 25.4 mm, 1 foot = 304.8 mm.

Note: Where footing Section "A" is less than 8 feet long in a 25-foot-long wall, install bracing at cripple stud wall.

FIGURE R602.11.3
STEPPED FOUNDATION CONSTRUCTION

wall beyond the segment of footing that extends to the lowest framed floor shall be spliced by extending the upper top plate a minimum of 4 feet (1219 mm) along the foundation. Anchor bolts shall be located a maximum of 1 foot and 3 feet (305 and 914 mm) from each end of the plate section at the step in the foundation.

3. Where cripple walls occur between the top of the foundation and the lowest floor framing, the bracing requirements for a story shall apply.
4. Where only the bottom of the foundation is stepped and the lowest floor framing rests directly on a sill bolted to the foundations, the requirements of Section R602.11.1 shall apply.

**SECTION R603
STEEL WALL FRAMING**

R603.1 General. Elements shall be straight and free of any defects that would significantly affect structural performance. Cold-formed steel wall framing members shall comply with the requirements of this section.

R603.1.1 Applicability limits. The provisions of this section shall control the construction of exterior steel wall framing and interior load-bearing steel wall framing for buildings not more than 60 feet (18 288 mm) long perpendicular to the joist or truss span, not more than 40 feet (12 192 mm) wide parallel to the joist or truss span, and not more than two stories in height. All exterior walls installed in accordance with the provisions of this section shall be considered as load-bearing walls. Steel walls constructed in accordance with the provisions of this section shall be limited to sites subjected to a maximum design wind speed of 110 miles per hour (49 m/s) Exposure A, B or C and a maximum ground snow load of 70 psf (3.35 kPa).

R603.1.2 In-line framing. Load-bearing steel studs constructed in accordance with Section R603 shall be located directly in-line with joists, trusses and rafters with a maximum tolerance of 3/4 inch (19.1 mm) between their center lines. Interior load-bearing steel stud walls shall be supported on foundations or shall be located directly above load-bearing walls with a maximum tolerance of 3/4 inch (19 mm) between the centerline of the studs.

R603.2 Structural framing. Load-bearing steel wall framing members shall comply with Figure R603.2(1) and with the dimensional and minimum thickness requirements specified in Tables R603.2(1) and R603.2(2). Tracks shall comply with Figure R603.2(2) and shall have a minimum flange width of 1 1/4 inches (32 mm). The maximum inside bend radius for members shall be the greater of 3/32 inch (2.4 mm) or twice the uncoated steel thickness. Holes in wall studs and other structural members shall comply with all of the following conditions:

1. Holes shall conform to Figure R603.2(3);
2. Holes shall be permitted only along the centerline of the web of the framing member;
3. Holes shall have a center-to-center spacing of not less than 24 inches (610 mm);
4. Holes shall have a width not greater than 0.5 times the member depth, or 1 1/2 inches (38.1 mm);
5. Holes shall have a length not exceeding 4 1/2 inches (114 mm); and
6. Holes shall have a minimum distance between the edge of the bearing surface and the edge of the hole of not less than 10 inches (254 mm).

Framing members with web holes violating the above requirements shall be patched in accordance with Section R603.3.5 or designed in accordance with accepted engineering practices.

**TABLE R603.2(1)
LOAD-BEARING COLD-FORMED STEEL STUD SIZES**

MEMBER DESIGNATION ^a	WEB DEPTH (inches)	MINIMUM FLANGE WIDTH (inches)	MAXIMUM FLANGE WIDTH (inches)	MINIMUM LIP SIZE (inches)
350S162-t	3.5	1.625	2	0.5
550S162-t	5.5	1.625	2	0.5

For SI: 1 inch = 25.4 mm; 1 mil = 0.0254 mm.

a. The member designation is defined by the first number representing the member depth in hundredths of an inch “S” representing a stud or joist member, the second number representing the flange width in hundredths of an inch, and the letter “t” shall be a number representing the minimum base metal thickness in mils [See Table R603.2(2)].

**TABLE R603.2(2)
MINIMUM THICKNESS OF COLD-FORMED STEEL STUDS**

DESIGNATION (mils)	MINIMUM UNCOATED THICKNESS (inches)	REFERENCE GAGE NUMBER
33	0.033	20
43	0.043	18
54	0.054	16
68	0.068	14

For SI: 1 inch = 25.4 mm, 1 mil = 0.0254 mm.

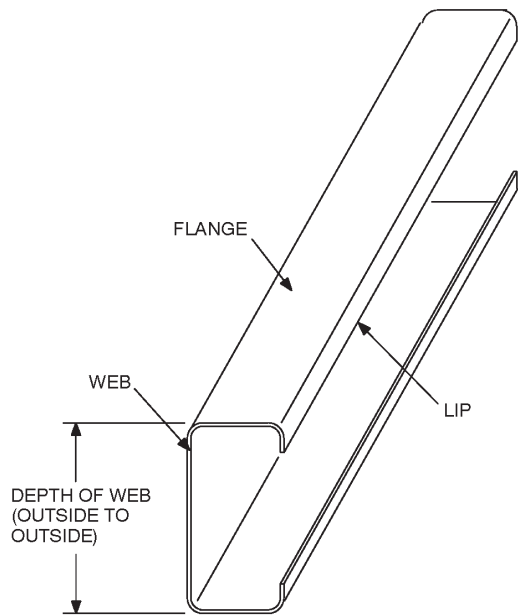

FIGURE R603.2(1)
C-SECTION

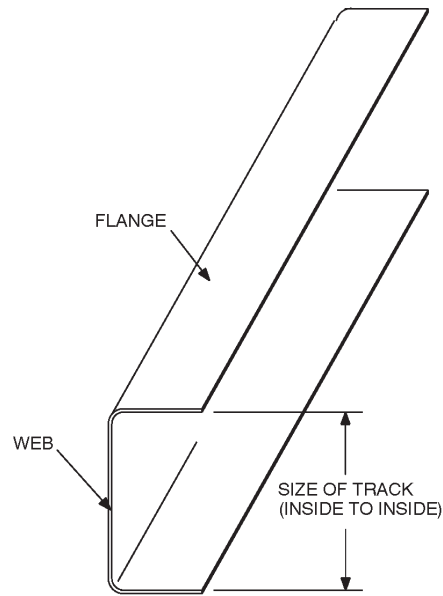

FIGURE R603.2(2)
TRACK SECTION

R603.2.1 Material. Load-bearing steel framing members shall be cold-formed to shape from structural quality sheet steel complying with the requirements of one of the following:

1. ASTM A 653: Grades 33, 37, 40 and 50 (Class 1 and 3).
2. ASTM A 792: Grades 33, 37, 40 and 50A.
3. ASTM A 875: Grades 33, 37, 40 and 50 (Class 1 and 3).
4. ASTM A 1003: Grades 33, 37, 40 and 50.

R603.2.2 Identification. Load-bearing steel framing members shall have a legible label, stencil, stamp or embossment with the following information as a minimum:

1. Manufacturer's identification.
2. Minimum uncoated steel thickness in inches (mm).
3. Minimum coating designation.
4. Minimum yield strength, in kips per square inch (ksi) (kN).

R603.2.3 Corrosion protection. Load-bearing steel framing shall have a metallic coating complying with one of the following:

1. A minimum of G 60 in accordance with ASTM A 653.
2. A minimum of AZ 50 in accordance with ASTM A 792.
3. A minimum of GF 60 in accordance with ASTM A 875.

R603.2.4 Fastening requirements. Screws for steel-to-steel connections shall be installed with a minimum edge distance

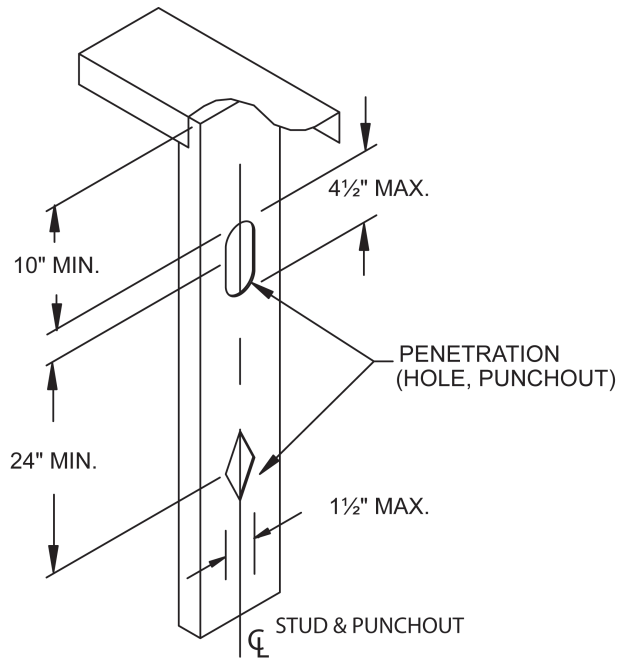

For SI: 1 inch = 25.4 mm.

FIGURE R603.2(3)
WEB HOLES

and center-to-center spacing of $\frac{1}{2}$ inch (12.7 mm), shall be self-drilling tapping and shall conform to SAE J 78. Structural sheathing shall be attached to steel studs with minimum No. 8 self-drilling tapping screws that conform to SAE J 78. Screws for attaching structural sheathing to steel wall framing shall have a minimum head diameter of 0.292 inch (7.4 mm) with countersunk heads and shall be installed with a minimum edge distance of $\frac{3}{8}$ inch (9.5 mm). Gypsum board shall be attached

to steel wall framing with minimum No. 6 screws conforming to ASTM C 954 and shall be installed in accordance with Section R702. For all connections, screws shall extend through the steel a minimum of three exposed threads. All self-drilling tapping screws conforming to SAE J 78 shall have a Type II coating in accordance with ASTM B 633.

Where No. 8 screws are specified in a steel-to-steel connection the required number of screws in the connection is permitted to be reduced in accordance with the reduction factors in Table R603.2.4, when larger screws are used or when one of the sheets of steel being connected is thicker than 33 mils (0.84 mm). When applying the reduction factor the resulting number of screws shall be rounded up.

**TABLE R603.2.4
SCREW SUBSTITUTION FACTOR**

SCREW SIZE	THINNEST CONNECTED STEEL SHEET (mils)	
	33	43
#8	1.0	0.67
#10	0.93	0.62
#12	0.86	0.56

For SI: 1 mil = 0.0254 mm.

R603.3 Wall construction. All exterior steel framed walls and interior load-bearing steel framed walls shall be constructed in accordance with the provisions of this section and Figure R603.3.

R603.3.1 Wall to foundation or floor connections. Steel framed walls shall be anchored to foundations or floors in accordance with Table R603.3.1 and Figure R603.3.1(1) or R603.3.1(2).

R603.3.2 Load-bearing walls. Steel studs shall comply with Tables R603.3.2(2) through R603.3.2(21). The tabulated stud thickness for structural walls shall be used when the attic load is 10 psf (0.48 kPa) or less. When an attic storage load is greater than 10 psf (0.48 kPa) but less than or equal to 20 psf (0.96 kPa), the next higher snow load column value from Tables R603.3.2(2) through R603.3.2(21) shall be used to select the stud size. The tabulated stud thickness for structural walls supporting one floor, roof and ceiling shall be used when the second floor live load is 30 psf (1.44 kPa). When the second floor live load is greater than 30 psf (1.44 kPa) but less than or equal to 40 psf (1.92 kPa) the design value in the next higher snow load column from Tables R603.2(12) through R603.3.2(21) shall be used to select the stud size.

Fastening requirements shall be in accordance with Section R603.2.4 and Table R603.3.2(1). Tracks shall have the same minimum thickness as the wall studs. Exterior walls with a minimum of 1/2-inch (13 mm) gypsum board installed in accordance with Section R702 on the interior surface and wood structural panels of minimum 7/16-inch thick (11 mm) oriented-strand board or 15/32-inch thick (12 mm) plywood installed in accordance with Table R603.3.2(1) on the outside surface shall be permitted to use the next thinner stud from Tables R603.3.2(2) through R603.3.2(13) but not less than 33 mils (0.84 mm). Interior load-bearing walls with a minimum 1/2-inch (13 mm) gypsum board installed in accordance with Section R702 on both sides of the wall shall be permitted to use

the next thinner stud from Tables R603.3.2(2) through R603.3.2(13) but not less than 33 mils (0.84 mm).

R603.3.3 Stud bracing. The flanges of steel studs shall be laterally braced in accordance with one of the following:

1. Gypsum board installed with minimum No. 6 screws in accordance with Section R702 or structural sheathing installed in accordance with Table R603.3.2(1).
2. Horizontal steel strapping installed in accordance with Figure R603.3 at mid-height for 8-foot (2438 mm) walls, and one-third points for 9-foot and 10-foot (2743 mm and 3048 mm) walls. Steel straps shall be at least 1.5 inches in width and 33 mils in thickness (38 mm by 0.84 mm). Straps shall be attached to the flanges of studs with at least one No. 8 screw. In-line blocking shall be installed between studs at the termination of all straps. Straps shall be fastened to the blocking with at least two No. 8 screws.
3. Sheathing on one side and strapping on the other side. Sheathing shall be installed in accordance with Method #1 above. Steel straps shall be installed in accordance with Method #2 above.

R603.3.4 Cutting and notching. Flanges and lips of steel studs and headers shall not be cut or notched.

R603.3.5 Hole patching. Web holes violating the requirements in Section R603.2 shall be designed in accordance with one of the following:

1. Framing members shall be replaced or designed in accordance with accepted engineering practices when web holes exceed the following size limits:
 - 1.1. The depth of the hole, measured across the web, exceeds 70 percent of the flat width of the web; or
 - 1.2. The length of the hole measured along the web exceeds 10 inches (254 mm) or the depth of the web, whichever is greater.
2. Web holes not exceeding the dimensional requirements in R603.3.5(1) shall be patched with a solid steel plate, stud section, or track section in accordance with Figure R603.3.5. The steel patch shall be as a minimum the same thickness as the receiving member and shall extend at least 1 inch (25 mm) beyond all edges of the hole. The steel patch shall be fastened to the web of the receiving member with No. 8 screws spaced no more than 1 inch (25 mm) center-to-center along the edges of the patch with a minimum edge distance of 1/2 inch (13 mm).

R603.3.6 Splicing. Steel studs and other structural members shall not be spliced. Tracks shall be spliced in accordance with Figure R603.3.6.

R603.4 Corner framing. Corner studs and the top tracks shall be installed in accordance with Figure R603.4.

R603.5 Exterior wall covering. The method of attachment of exterior wall covering materials to cold-formed steel stud wall framing shall conform to the manufacturer's installation instructions.

WALL CONSTRUCTION

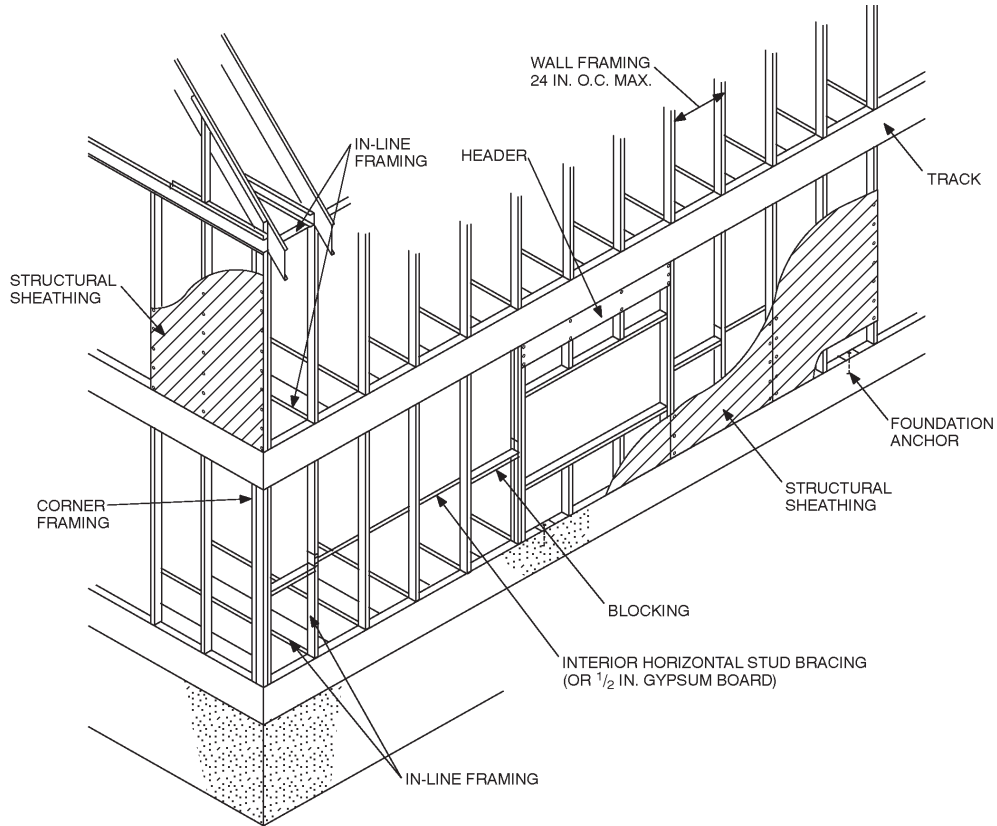

For SI: 1 inch = 25.4 mm.

**FIGURE R603.3
STEEL WALL CONSTRUCTION**

**TABLE R603.3.1
WALL TO FOUNDATION OR FLOOR CONNECTION REQUIREMENTS^{a,b,c}**

FRAMING CONDITION	BASIC WIND SPEED (mph) AND EXPOSURE		
	85 A/B or Seismic Design Categories A, B and C	85 C or less than 110 A/B	Less than 110 C
Wall bottom track to floor joist or track	1-No. 8 screw at 12" o.c.	1-No. 8 screw at 12" o.c.	2-No. 8 screw at 12" o.c.
Wall bottom track to wood sill per Figure R603.3.1(2)	Steel plate spaced at 4' o.c., with 4-No. 8 screws and 4-10d or 6-8d common nails	Steel plate spaced at 3' o.c., with 4-No. 8 screws and 4-10d or 6-8d common nails	Steel plate spaced at 2' o.c., with 4-No. 8 screws and 4-10d or 6-8d common nails
Wall bottom track to foundation per Figure R603.3.1(1)	1/2" minimum diameter anchor bolt at 6' o.c.	1/2" minimum diameter anchor bolt at 6' o.c.	1/2" minimum diameter anchor bolt at 4' o.c.
Wind uplift connector capacity for 16-inch stud spacing ^c	N/R	N/R	65 lb
Wind uplift connector capacity for 24-inch stud spacing ^c	N/R	N/R	100 lb

For SI: 1 inch = 25.4 mm, 1 foot = 304.8 mm, 1 mile per hour = 0.447 m/s, 1 pound = 4.4 N.

- a. Anchor bolts shall be located not more than 12 inches from corners or the termination of bottom tracks (e.g., at door openings or corners). Bolts shall extend a minimum of 7 inches into concrete or masonry.
- b. All screw sizes shown are minimum.
- c. N/R = uplift connector not required. Uplift connectors are in addition to other connection requirements and shall be applied in accordance with Section R603.8.

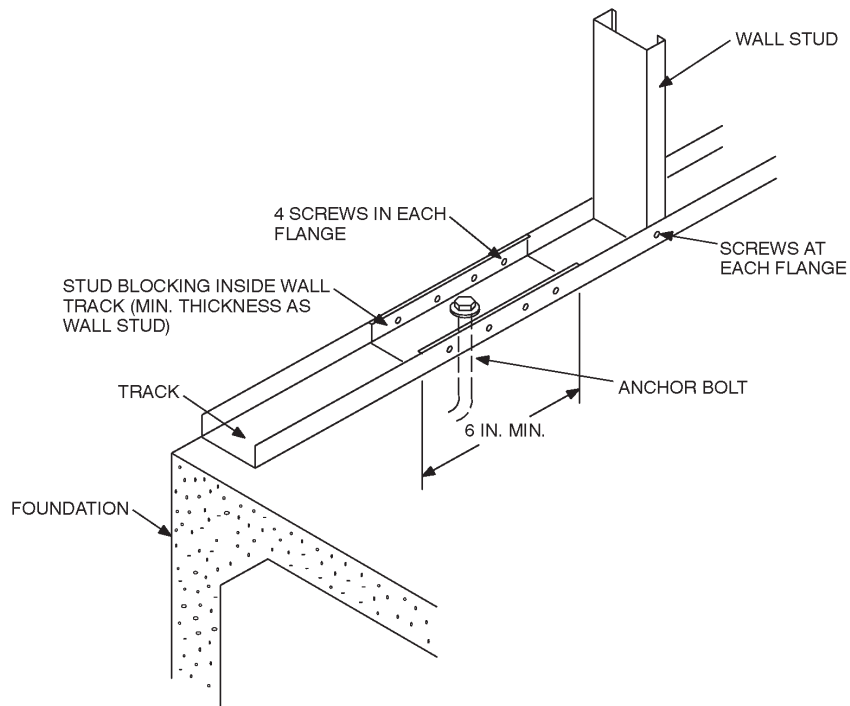

For SI: 1 inch = 25.4 mm.

FIGURE R603.3.1(1)
WALL TO FOUNDATION CONNECTION

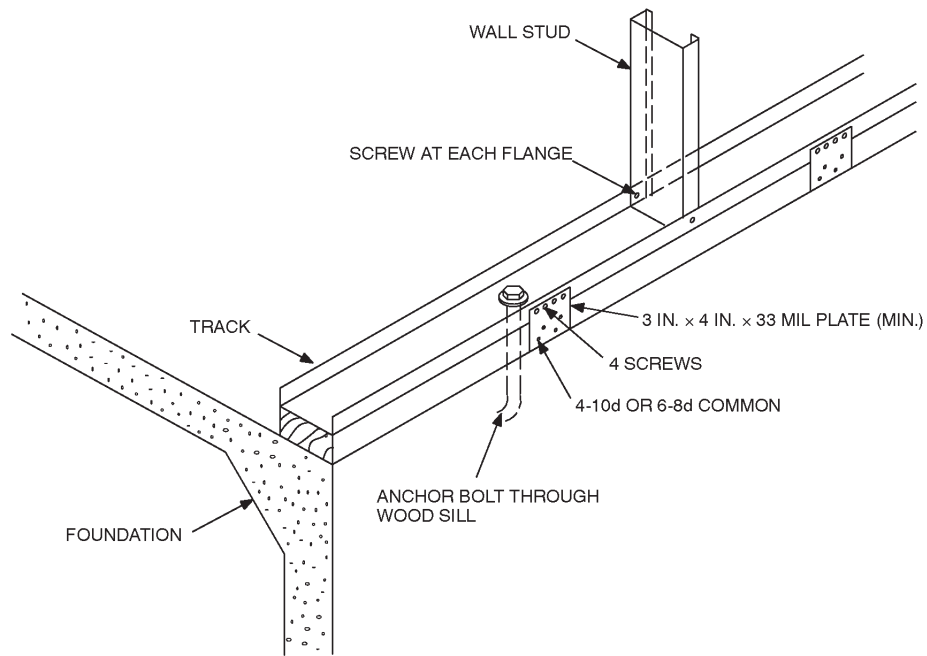

For SI: 1 inch = 25.4 mm.

FIGURE R603.3.1(2)
WALL TO WOOD SILL CONNECTION

TABLE R603.3.2(1)
WALL FASTENING SCHEDULE^a

DESCRIPTION OF BUILDING ELEMENT	NUMBER AND SIZE OF FASTENERS ^a	SPACING OF FASTENERS
Floor joist to track of load-bearing wall	2-No. 8 screws	Each joist
Wall stud to top or bottom track	2-No. 8 screws	Each end of stud, one per flange
Structural sheathing to wall studs	No. 8 screws	6" o.c. on edges and 12" o.c. at intermediate supports
Roof framing to wall	Approved design or tie down in accordance with Section R802.11	

For SI: 1 inch = 25.4 mm.

a. All screw sizes shown are minimum.

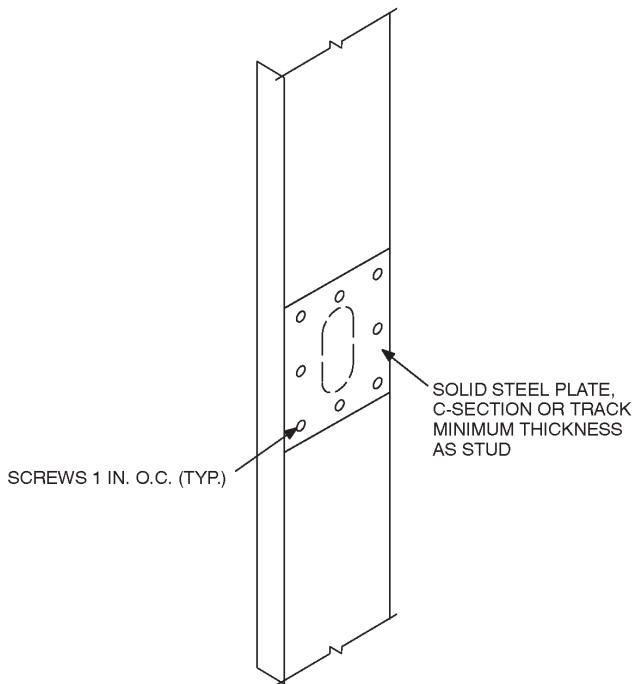

For SI: 1 inch = 25.4 mm.

FIGURE R603.3.5
HOLE PATCH

R603.6 Headers. Headers shall be installed above wall openings in all exterior walls and interior load-bearing walls in accordance with Figure R603.6 and Tables R603.6(1) through R603.6(8), or shall be designed in accordance with the AISI Standard for Cold-formed Steel Framing—Header Design (COFS/Header Design).

R603.6.1 Jack and king studs, and head track. The number of jack and king studs shall comply with Table R603.6(9). King and jack studs shall be of the same dimension and thickness as the adjacent wall studs. Headers constructed of C-shape framing members shall be connected to king studs in accordance with Table R603.6.(10). One-half the total number of screws shall be applied to the header and one-half to the king stud by use of a minimum 2-inch by 2-inch (51 mm by 51 mm) clip angle or 4-inch-wide (102 mm) steel plate. The clip angle or plate shall extend the depth of the header minus $\frac{1}{2}$ inch (13 mm) and shall have a minimum thickness of the header members or the wall studs, whichever is thicker.

Head track spans shall comply with Table R603.6(11) and shall be in accordance with Figures R603.3 and R603.6. Increasing the head track tabular value shall not be prohibited when in accordance with one of the following:

1. For openings less than 4 feet (1219 mm) in height that have a top and bottom head track, multiply the tabular value by 1.75; or
2. For openings less than 6 feet (1829 mm) in height that have a top and bottom head track, multiply the tabular value by 1.50.

R603.7 Structural sheathing. In areas where the basic wind speed is less than 110 miles per hour (49 m/s), wood structural panel sheathing shall be installed on all exterior walls of buildings in accordance with this section. Wood structural panel sheathing shall consist of minimum $\frac{7}{16}$ -inch-thick (11 mm) oriented-strand board or $\frac{15}{32}$ -inch-thick (12 mm) plywood and shall be installed on all exterior wall surfaces in accordance with Section R603.7.1 and Figure R603.3. The minimum length of full height sheathing on exterior walls shall be determined in accordance with Table R603.7, but shall not be less than 20 percent of the braced wall length in any case. The minimum percentage of full height sheathing in Table R603.7 shall include only those sheathed wall sections, uninterrupted by openings, which are a minimum of 48 inches (1120 mm) wide. The minimum percentage of full-height structural sheathing shall be multiplied by 1.10 for 9-foot-high (2743 mm) walls and multiplied by 1.20 for 10-foot-high (3048 mm) walls. In addition, structural sheathing shall:

1. Be installed with the long dimension parallel to the stud framing and shall cover the full vertical height of studs, from the bottom of the bottom track to the top of the top track of each story.
2. Be applied to each end (corners) of each of the exterior walls with a minimum 48-inch-wide (1219 mm) panel.

R603.7.1 Structural sheathing fastening. All edges and interior areas of wood structural panel sheathing shall be fastened to a framing member and tracks in accordance with Table R603.3.2(1).

R603.7.2 Hold-down requirements. Multiplying the percentage of structural sheathing required in Table R603.7 by 0.6 is permitted where a hold-down anchor with a capacity of 4,300 pounds (19 kN) is provided at each end of exterior walls. Installations of a single hold-down anchor at wall corners is permitted.

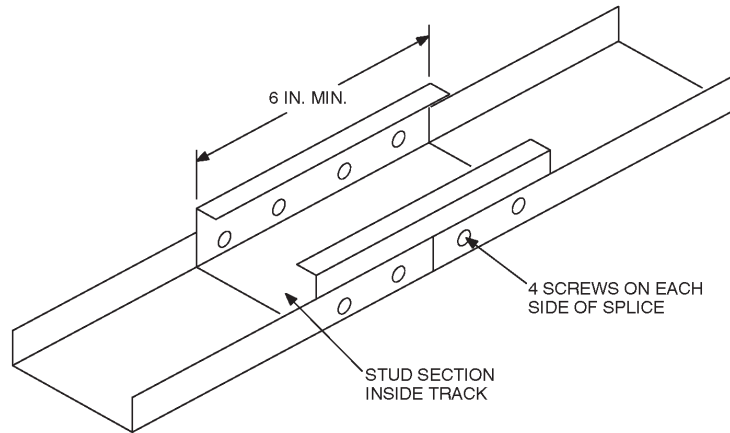

For SI: 1 inch = 25.4 mm.

**FIGURE R603.3.6
TRACK SPLICE**

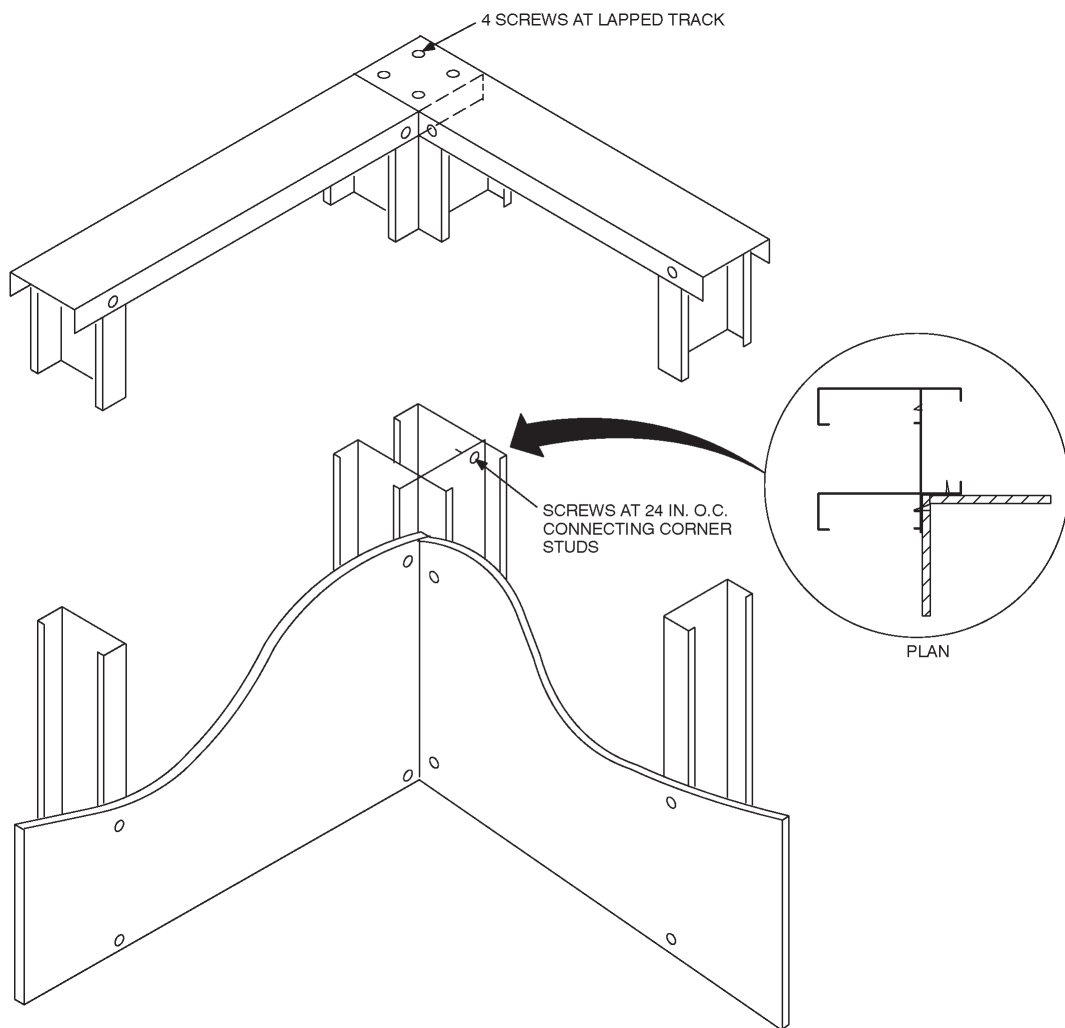

For SI: 1 inch = 25.4

**FIGURE R603.4
CORNER FRAMING**

TABLE R603.3.2(2)
24-FOOT-WIDE BUILDING SUPPORTING ROOF AND CEILING ONLY^{a, b, c}
33 ksi STEEL

WIND SPEED		MEMBER SIZE	STUD SPACING (inches)	MINIMUM STUD THICKNESS (mils)													
				8-Foot Studs				9-Foot Studs				10-Foot Studs					
Exp. A/B	Exp. C			Ground Snow Load (psf)													
				20	30	50	70	20	30	50	70	20	30	50	70		
85 mph	—	350S162	16	33	33	33	33	33	33	33	33	33	33	33	33	33	
			24	33	33	33	33	33	33	33	33	33	33	33	33	43	
		550S162	16	33	33	33	33	33	33	33	33	33	33	33	33	33	33
			24	33	33	33	33	33	33	33	33	33	33	33	33	33	33
90 mph	—	350S162	16	33	33	33	33	33	33	33	33	33	33	33	33	33	
			24	33	33	33	33	33	33	33	33	33	33	33	43		
		550S162	16	33	33	33	33	33	33	33	33	33	33	33	33	33	
			24	33	33	33	33	33	33	33	33	33	33	33	33	33	
100 mph	85 mph	350S162	16	33	33	33	33	33	33	33	33	33	33	33	33	33	
			24	33	33	33	33	33	33	33	33	33	33	33	43		
		550S162	16	33	33	33	33	33	33	33	33	33	33	33	33	33	
			24	33	33	33	33	33	33	33	33	33	33	33	33	33	
110 mph	90 mph	350S162	16	33	33	33	33	33	33	33	33	33	33	33	33	33	
			24	33	33	33	33	33	33	33	43	33	33	33	43		
		550S162	16	33	33	33	33	33	33	33	33	33	33	33	33	33	
			24	33	33	33	33	33	33	33	33	33	33	33	33	33	
—	100 mph	350S162	16	33	33	33	33	33	33	33	33	33	33	33	33	33	
			24	33	33	33	43	33	33	33	43	43	43	43	43		
		550S162	16	33	33	33	33	33	33	33	33	33	33	33	33	33	
			24	33	33	33	33	33	33	33	33	33	33	33	33	33	
—	110 mph	350S162	16	33	33	33	33	33	33	33	33	33	33	33	33	33	
			24	33	33	33	43	43	43	43	43	54	54	54	54		
		550S162	16	33	33	33	33	33	33	33	33	33	33	33	33	33	
			24	33	33	33	33	33	33	33	33	33	33	33	33	33	

For SI: 1 inch = 25.4 mm, 1 foot = 304.8 mm, 1 mil = 0.0254 mm, 1 mile per hour = 0.447 m/s, 1 pound per square foot = 0.0479 kPa, 1 ksi = 1000 psi = 6.895 MPa.

- a. Deflection criterion: *L*/240.
- b. Design load assumptions:
 Roof/ceiling dead load is 12 psf.
 Attic live load is 10 psf.
- c. Building width is in the direction of horizontal framing members supported by the wall studs.

TABLE R603.3.2(3)
24-FOOT-WIDE BUILDING SUPPORTING ROOF AND CEILING ONLY^{a, b, c}
50 ksi STEEL

WIND SPEED		MEMBER SIZE	STUD SPACING (inches)	MINIMUM STUD THICKNESS (mils)													
				8-Foot Studs				9-Foot Studs				10-Foot Studs					
Exp. A/B	Exp. C			Ground Snow Load (psf)													
				20	30	50	70	20	30	50	70	20	30	50	70		
85 mph	—	350S162	16	33	33	33	33	33	33	33	33	33	33	33	33	33	
			24	33	33	33	33	33	33	33	33	33	33	33	33	33	33
		550S162	16	33	33	33	33	33	33	33	33	33	33	33	33	33	33
			24	33	33	33	33	33	33	33	33	33	33	33	33	33	33
90 mph	—	350S162	16	33	33	33	33	33	33	33	33	33	33	33	33	33	
			24	33	33	33	33	33	33	33	33	33	33	33	33	33	
		550S162	16	33	33	33	33	33	33	33	33	33	33	33	33	33	33
			24	33	33	33	33	33	33	33	33	33	33	33	33	33	33
100 mph	85 mph	350S162	16	33	33	33	33	33	33	33	33	33	33	33	33	33	
			24	33	33	33	33	33	33	33	33	33	33	33	33	33	
		550S162	16	33	33	33	33	33	33	33	33	33	33	33	33	33	33
			24	33	33	33	33	33	33	33	33	33	33	33	33	33	33
110 mph	90 mph	350S162	16	33	33	33	33	33	33	33	33	33	33	33	33	33	
			24	33	33	33	33	33	33	33	33	33	33	33	33	33	
		550S162	16	33	33	33	33	33	33	33	33	33	33	33	33	33	33
			24	33	33	33	33	33	33	33	33	33	33	33	33	33	33
—	100 mph	350S162	16	33	33	33	33	33	33	33	33	33	33	33	33	33	
			24	33	33	33	33	33	33	33	33	43	43	43	43		
		550S162	16	33	33	33	33	33	33	33	33	33	33	33	33	33	33
			24	33	33	33	33	33	33	33	33	33	33	33	33	33	33
—	110 mph	350S162	16	33	33	33	33	33	33	33	33	33	33	33	33	33	
			24	33	33	33	33	33	33	33	33	54	54	54	54		
		550S162	16	33	33	33	33	33	33	33	33	33	33	33	33	33	33
			24	33	33	33	33	33	33	33	33	33	33	33	33	33	33

For SI: 1 inch = 25.4 mm, 1 foot = 304.8 mm, 1 mil = 0.0254 mm, 1 mile per hour = 0.447 m/s, 1 pound per square foot = 0.0479 kPa, 1 ksi = 1000 psi = 6.895 MPa.

- a. Deflection criterion: $L/240$.
- b. Design load assumptions:
 Roof/ceiling dead load is 12 psf.
 Attic live load is 10 psf.
- c. Building width is in the direction of horizontal framing members supported by the wall studs.

TABLE R603.3.2(4)
28-FOOT-WIDE BUILDING SUPPORTING ROOF AND CEILING ONLY^{a, b, c}
33 ksi STEEL

WIND SPEED		MEMBER SIZE	STUD SPACING (inches)	MINIMUM STUD THICKNESS (mils)													
Exp. A/B	Exp. C			8-Foot Studs				9-Foot Studs				10-Foot Studs					
				Ground Snow Load (psf)													
				20	30	50	70	20	30	50	70	20	30	50	70		
85 mph	—	350S162	16	33	33	33	33	33	33	33	33	33	33	33	33	33	
			24	33	33	33	43	33	33	33	43	33	33	33	33	43	
		550S162	16	33	33	33	33	33	33	33	33	33	33	33	33	33	33
			24	33	33	33	33	33	33	33	33	33	33	33	33	33	33
90 mph	—	350S162	16	33	33	33	33	33	33	33	33	33	33	33	33	33	
			24	33	33	33	43	33	33	33	43	33	33	33	43		
		550S162	16	33	33	33	33	33	33	33	33	33	33	33	33	33	
			24	33	33	33	33	33	33	33	33	33	33	33	33	33	
100 mph	85 mph	350S162	16	33	33	33	33	33	33	33	33	33	33	33	33	33	
			24	33	33	33	43	33	33	33	43	33	33	43	43		
		550S162	16	33	33	33	33	33	33	33	33	33	33	33	33	33	
			24	33	33	33	33	33	33	33	33	33	33	33	33	33	
110 mph	90 mph	350S162	16	33	33	33	33	33	33	33	33	33	33	33	33	33	
			24	33	33	33	43	33	33	33	43	33	33	43	43		
		550S162	16	33	33	33	33	33	33	33	33	33	33	33	33	33	
			24	33	33	33	33	33	33	33	33	33	33	33	33	33	
—	100 mph	350S162	16	33	33	33	33	33	33	33	33	33	33	33	33	33	
			24	33	33	33	43	33	33	43	43	43	43	43	43		
		550S162	16	33	33	33	33	33	33	33	33	33	33	33	33	33	
			24	33	33	33	33	33	33	33	33	33	33	33	33	33	
—	110 mph	350S162	16	33	33	33	33	33	33	33	33	33	33	33	33	33	
			24	33	33	33	43	43	43	43	43	54	54	54	54		
		550S162	16	33	33	33	33	33	33	33	33	33	33	33	33	33	
			24	33	33	33	33	33	33	33	33	33	33	33	33	33	

For SI: 1 inch = 25.4 mm, 1 foot = 304.8 mm, 1 mil = 0.0254 mm, 1 mile per hour = 0.447 m/s, 1 pound per square foot = 0.0479 kPa, 1 ksi = 1000 psi = 6.895 MPa.

- a. Deflection criterion: $L/240$.
- b. Design load assumptions:
 Roof/ceiling dead load is 12 psf.
 Attic live load is 10 psf.
- c. Building width is in the direction of horizontal framing members supported by the wall studs.

TABLE R603.3.2(5)
28-FOOT-WIDE BUILDING SUPPORTING ROOF AND CEILING ONLY^{a, b, c}
50 ksi STEEL

WIND SPEED		MEMBER SIZE	STUD SPACING (inches)	MINIMUM STUD THICKNESS (mils)													
				8-Foot Studs				9-Foot Studs				10-Foot Studs					
Exp. A/B	Exp. C			Ground Snow Load (psf)													
				20	30	50	70	20	30	50	70	20	30	50	70		
85 mph	—	350S162	16	33	33	33	33	33	33	33	33	33	33	33	33	33	
			24	33	33	33	33	33	33	33	33	33	33	33	33	43	
		550S162	16	33	33	33	33	33	33	33	33	33	33	33	33	33	33
			24	33	33	33	33	33	33	33	33	33	33	33	33	33	33
90 mph	—	350S162	16	33	33	33	33	33	33	33	33	33	33	33	33	33	
			24	33	33	33	33	33	33	33	33	33	33	33	43		
		550S162	16	33	33	33	33	33	33	33	33	33	33	33	33	33	33
			24	33	33	33	33	33	33	33	33	33	33	33	33	33	33
100 mph	85 mph	350S162	16	33	33	33	33	33	33	33	33	33	33	33	33	33	
			24	33	33	33	33	33	33	33	33	33	33	33	43		
		550S162	16	33	33	33	33	33	33	33	33	33	33	33	33	33	33
			24	33	33	33	33	33	33	33	33	33	33	33	33	33	33
110 mph	90 mph	350S162	16	33	33	33	33	33	33	33	33	33	33	33	33	33	
			24	33	33	33	33	33	33	33	33	33	33	43	43		
		550S162	16	33	33	33	33	33	33	33	33	33	33	33	33	33	33
			24	33	33	33	33	33	33	33	33	33	33	33	33	33	33
—	100 mph	350S162	16	33	33	33	33	33	33	33	33	33	33	33	33	33	
			24	33	33	33	33	33	33	33	33	43	43	43	43		
		550S162	16	33	33	33	33	33	33	33	33	33	33	33	33	33	33
			24	33	33	33	33	33	33	33	33	33	33	33	33	33	33
—	110 mph	350S162	16	33	33	33	33	33	33	33	33	33	33	33	33	33	
			24	33	33	33	43	33	33	33	43	54	54	54	54		
		550S162	16	33	33	33	33	33	33	33	33	33	33	33	33	33	33
			24	33	33	33	33	33	33	33	33	33	33	33	33	33	33

For SI: 1 inch = 25.4 mm, 1 foot = 304.8 mm, 1 mil = 0.0254 mm, 1 mile per hour = 0.447 m/s, 1 pound per square foot = 0.0479 kPa, 1 ksi = 1000 psi = 6.895 MPa.

- a. Deflection criterion: $L/240$.
- b. Design load assumptions:
 Roof/ceiling dead load is 12 psf.
 Attic live load is 10 psf.
- c. Building width is in the direction of horizontal framing members supported by the wall studs.

TABLE R603.3.2(6)
32-FOOT-WIDE BUILDING SUPPORTING ROOF AND CEILING ONLY^{a, b, c}
33 ksi STEEL

WIND SPEED		MEMBER SIZE	STUD SPACING (inches)	MINIMUM STUD THICKNESS (mils)													
Exp. A/B	Exp. C			8-Foot Studs				9-Foot Studs				10-Foot Studs					
				Ground Snow Load (psf)													
				20	30	50	70	20	30	50	70	20	30	50	70		
85 mph	—	350S162	16	33	33	33	33	33	33	33	33	33	33	33	33	33	
			24	33	33	33	43	33	33	33	43	33	33	43	43		
		550S162	16	33	33	33	33	33	33	33	33	33	33	33	33	33	33
			24	33	33	33	33	33	33	33	33	33	33	33	33	33	33
90 mph	—	350S162	16	33	33	33	33	33	33	33	33	33	33	33	33	33	
			24	33	33	33	43	33	33	33	43	33	33	43	43		
		550S162	16	33	33	33	33	33	33	33	33	33	33	33	33	33	
			24	33	33	33	33	33	33	33	33	33	33	33	33	33	
100 mph	85 mph	350S162	16	33	33	33	33	33	33	33	33	33	33	33	33	33	
			24	33	33	33	43	33	33	33	43	33	33	43	43		
		550S162	16	33	33	33	33	33	33	33	33	33	33	33	33	33	
			24	33	33	33	33	33	33	33	33	33	33	33	33	33	
110 mph	90 mph	350S162	16	33	33	33	33	33	33	33	33	33	33	33	33	33	
			24	33	33	33	43	33	33	33	43	33	33	43	43		
		550S162	16	33	33	33	33	33	33	33	33	33	33	33	33	33	
			24	33	33	33	33	33	33	33	33	33	33	33	33	33	
—	100 mph	350S162	16	33	33	33	33	33	33	33	33	33	33	33	33	43	
			24	33	33	43	43	33	43	43	43	43	43	43	43	54	
		550S162	16	33	33	33	33	33	33	33	33	33	33	33	33	33	
			24	33	33	33	33	33	33	33	33	33	33	33	33	43	
—	110 mph	350S162	16	33	33	33	33	33	33	33	33	33	33	33	33	43	
			24	33	33	43	43	33	43	43	43	54	54	54	54		
		550S162	16	33	33	33	33	33	33	33	33	33	33	33	33	33	
			24	33	33	33	33	33	33	33	33	33	33	33	33	43	

For SI: 1 inch = 25.4 mm, 1 foot = 304.8 mm, 1 mil = 0.0254 mm, 1 mile per hour = 0.447 m/s, 1 pound per square foot = 0.0479 kPa, 1 ksi = 1000 psi = 6.895 MPa.

- a. Deflection criterion: $L/240$.
- b. Design load assumptions:
 Roof/ceiling dead load is 12 psf.
 Attic live load is 10 psf.
- c. Building width is in the direction of horizontal framing members supported by the wall studs.

TABLE R603.3.2(7)
32-FOOT-WIDE BUILDING SUPPORTING ROOF AND CEILING ONLY^{a, b, c}
50 ksi STEEL

WIND SPEED		MEMBER SIZE	STUD SPACING (inches)	MINIMUM STUD THICKNESS (mils)														
				8-Foot Studs				9-Foot Studs				10-Foot Studs						
Exp. A/B	Exp. C			Ground Snow Load (psf)														
				20	30	50	70	20	30	50	70	20	30	50	70			
85 mph	—	350S162	16	33	33	33	33	33	33	33	33	33	33	33	33	33		
			24	33	33	33	33	33	33	33	33	33	33	33	33	33	43	
		550S162	16	33	33	33	33	33	33	33	33	33	33	33	33	33	33	33
			24	33	33	33	33	33	33	33	33	33	33	33	33	33	33	33
90 mph	—	350S162	16	33	33	33	33	33	33	33	33	33	33	33	33	33	33	
			24	33	33	33	33	33	33	33	33	33	33	33	33	33	43	
		550S162	16	33	33	33	33	33	33	33	33	33	33	33	33	33	33	33
			24	33	33	33	33	33	33	33	33	33	33	33	33	33	33	33
100 mph	85 mph	350S162	16	33	33	33	33	33	33	33	33	33	33	33	33	33	33	
			24	33	33	33	43	33	33	33	33	33	33	33	33	33	43	
		550S162	16	33	33	33	33	33	33	33	33	33	33	33	33	33	33	33
			24	33	33	33	33	33	33	33	33	33	33	33	33	33	33	33
110 mph	90 mph	350S162	16	33	33	33	33	33	33	33	33	33	33	33	33	33	33	
			24	33	33	33	43	33	33	33	33	33	33	33	33	33	43	
		550S162	16	33	33	33	33	33	33	33	33	33	33	33	33	33	33	33
			24	33	33	33	33	33	33	33	33	33	33	33	33	33	33	33
—	100 mph	350S162	16	33	33	33	33	33	33	33	33	33	33	33	33	33	33	
			24	33	33	33	43	33	33	33	43	43	43	43	43	43	43	
		550S162	16	33	33	33	33	33	33	33	33	33	33	33	33	33	33	33
			24	33	33	33	33	33	33	33	33	33	33	33	33	33	33	33
—	110 mph	350S162	16	33	33	33	33	33	33	33	33	33	33	33	33	33	33	
			24	33	33	33	43	33	33	33	43	54	54	54	54	54	54	
		550S162	16	33	33	33	33	33	33	33	33	33	33	33	33	33	33	33
			24	33	33	33	33	33	33	33	33	33	33	33	33	33	33	33

For SI: 1 inch = 25.4 mm, 1 foot = 304.8 mm, 1 mil = 0.0254 mm, 1 mile per hour = 0.447 m/s, 1 pound per square foot = 0.0479 kPa, 1 ksi = 1000 psi = 6.895 MPa.

- a. Deflection criterion: $L/240$.
- b. Design load assumptions:
 Roof/ceiling dead load is 12 psf.
 Attic live load is 10 psf.
- c. Building width is in the direction of horizontal framing members supported by the wall studs.

TABLE R603.3.2(8)
36-FOOT-WIDE BUILDING SUPPORTING ROOF AND CEILING ONLY^{a, b, c}
33 ksi STEEL

WIND SPEED		MEMBER SIZE	STUD SPACING (inches)	MINIMUM STUD THICKNESS (mils)													
Exp. A/B	Exp. C			8-Foot Studs				9-Foot Studs				10-Foot Studs					
				Ground Snow Load (psf)													
				20	30	50	70	20	30	50	70	20	30	50	70		
85 mph	—	350S162	16	33	33	33	33	33	33	33	33	33	33	33	33	33	
			24	33	33	43	43	33	33	33	43	33	33	43	43		
		550S162	16	33	33	33	33	33	33	33	33	33	33	33	33	33	33
			24	33	33	33	33	33	33	33	33	33	33	33	33	33	33
90 mph	—	350S162	16	33	33	33	33	33	33	33	33	33	33	33	33	33	
			24	33	33	43	43	33	33	33	43	33	33	43	43		
		550S162	16	33	33	33	33	33	33	33	33	33	33	33	33	33	33
			24	33	33	33	33	33	33	33	33	33	33	33	33	33	33
100 mph	85 mph	350S162	16	33	33	33	33	33	33	33	33	33	33	33	33	33	
			24	33	33	33	43	33	33	43	43	33	33	43	54		
		550S162	16	33	33	33	33	33	33	33	33	33	33	33	33	33	33
			24	33	33	33	33	33	33	33	33	33	33	33	33	33	43
110 mph	90 mph	350S162	16	33	33	33	33	33	33	33	33	33	33	33	33	33	
			24	33	33	43	43	33	33	43	43	33	43	43	54		
		550S162	16	33	33	33	33	33	33	33	33	33	33	33	33	33	33
			24	33	33	33	33	33	33	33	33	33	33	33	33	33	43
—	100 mph	350S162	16	33	33	33	33	33	33	33	33	33	33	33	33	43	
			24	33	33	43	43	43	43	43	43	43	43	43	54		
		550S162	16	33	33	33	33	33	33	33	33	33	33	33	33	33	
			24	33	33	33	43	33	33	33	43	33	33	33	33	43	
—	110 mph	350S162	16	33	33	33	33	33	33	33	33	33	33	33	33	43	
			24	33	33	43	54	43	43	43	54	54	54	54	54		
		550S162	16	33	33	33	33	33	33	33	33	33	33	33	33	33	
			24	33	33	33	43	33	33	33	43	33	33	33	33	33	

For SI: 1 inch = 25.4 mm, 1 foot = 304.8 mm, 1 mil = 0.0254 mm, 1 mile per hour = 0.447 m/s, 1 pound per square foot = 0.0479 kPa, 1 ksi = 1000 psi = 6.895 MPa.

- a. Deflection criterion: $L/240$.
- b. Design load assumptions:
 Roof/ceiling dead load is 12 psf.
 Attic live load is 10 psf.
- c. Building width is in the direction of horizontal framing members supported by the wall studs.

TABLE R603.3.2(9)
36-FOOT-WIDE BUILDING SUPPORTING ROOF AND CEILING ONLY^{a, b, c}
50 ksi STEEL

WIND SPEED		MEMBER SIZE	STUD SPACING (inches)	MINIMUM STUD THICKNESS (mils)													
				8-Foot Studs				9-Foot Studs				10-Foot Studs					
Exp. A/B	Exp. C			Ground Snow Load (psf)													
				20	30	50	70	20	30	50	70	20	30	50	70		
85 mph	—	350S162	16	33	33	33	33	33	33	33	33	33	33	33	33	33	
			24	33	33	33	43	33	33	33	43	33	33	33	33	33	43
		550S162	16	33	33	33	33	33	33	33	33	33	33	33	33	33	33
			24	33	33	33	33	33	33	33	33	33	33	33	33	33	33
90 mph	—	350S162	16	33	33	33	33	33	33	33	33	33	33	33	33	33	
			24	33	33	33	43	33	33	33	43	33	33	33	33	43	
		550S162	16	33	33	33	33	33	33	33	33	33	33	33	33	33	33
			24	33	33	33	33	33	33	33	33	33	33	33	33	33	33
100 mph	85 mph	350S162	16	33	33	33	33	33	33	33	33	33	33	33	33	33	
			24	33	33	33	43	33	33	33	43	33	33	33	33	43	
		550S162	16	33	33	33	33	33	33	33	33	33	33	33	33	33	33
			24	33	33	33	33	33	33	33	33	33	33	33	33	33	33
110 mph	90 mph	350S162	16	33	33	33	33	33	33	33	33	33	33	33	33	33	
			24	33	33	33	43	33	33	33	43	33	33	33	43	43	
		550S162	16	33	33	33	33	33	33	33	33	33	33	33	33	33	33
			24	33	33	33	33	33	33	33	33	33	33	33	33	33	33
—	100 mph	350S162	16	33	33	33	33	33	33	33	33	33	33	33	33	33	
			24	33	33	33	43	33	33	33	43	43	43	43	43	43	
		550S162	16	33	33	33	33	33	33	33	33	33	33	33	33	33	33
			24	33	33	33	33	33	33	33	33	33	33	33	33	33	33
—	110 mph	350S162	16	33	33	33	33	33	33	33	33	33	33	33	33	33	
			24	33	33	33	43	33	33	33	43	54	54	54	54	54	
		550S162	16	33	33	33	33	33	33	33	33	33	33	33	33	33	33
			24	33	33	33	33	33	33	33	33	33	33	33	33	33	33

For SI: 1 inch = 25.4 mm, 1 foot = 304.8 mm, 1 mil = 0.0254 mm, 1 mile per hour = 0.447 m/s, 1 pound per square foot = 0.0479 kPa, 1 ksi = 1000 psi = 6.895 MPa.

- a. Deflection criterion: $L/240$.
- b. Design load assumptions:
 Roof/ceiling dead load is 12 psf.
 Attic live load is 10 psf.
- c. Building width is in the direction of horizontal framing members supported by the wall studs.

TABLE R603.3.2(10)
40-FOOT-WIDE BUILDING SUPPORTING ROOF AND CEILING ONLY^{a, b, c}
33 ksi STEEL

WIND SPEED		MEMBER SIZE	STUD SPACING (inches)	MINIMUM STUD THICKNESS (mils)													
Exp. A/B	Exp. C			8-Foot Studs				9-Foot Studs				10-Foot Studs					
				Ground Snow Load (psf)													
				20	30	50	70	20	30	50	70	20	30	50	70		
85 mph	—	350S162	16	33	33	33	33	33	33	33	33	33	33	33	33	43	
			24	33	33	43	43	33	33	43	43	33	33	43	43	54	
		550S162	16	33	33	33	33	33	33	33	33	33	33	33	33	33	33
			24	33	33	33	43	33	33	33	33	33	33	33	33	33	43
90 mph	—	350S162	16	33	33	33	33	33	33	33	33	33	33	33	33	43	
			24	33	33	43	43	33	33	43	43	33	33	43	54		
		550S162	16	33	33	33	33	33	33	33	33	33	33	33	33	33	
			24	33	33	33	43	33	33	33	33	33	33	33	33	43	
100 mph	85 mph	350S162	16	33	33	33	33	33	33	33	33	33	33	33	33	43	
			24	33	33	43	43	33	33	43	43	33	33	43	54		
		550S162	16	33	33	33	33	33	33	33	33	33	33	33	33	33	
			24	33	33	33	43	33	33	33	33	43	33	33	33	43	
110 mph	90 mph	350S162	16	33	33	33	33	33	33	33	33	33	33	33	33	43	
			24	33	33	43	54	33	33	43	43	43	43	43	54		
		550S162	16	33	33	33	33	33	33	33	33	33	33	33	33	33	
			24	33	33	33	43	33	33	33	33	43	33	33	33	43	
—	100 mph	350S162	16	33	33	33	43	33	33	33	43	33	33	33	43		
			24	33	33	43	54	43	43	43	54	43	43	43	54		
		550S162	16	33	33	33	33	33	33	33	33	33	33	33	33		
			24	33	33	33	43	33	33	33	33	43	33	33	33	43	
—	110 mph	350S162	16	33	33	33	43	33	33	33	43	33	33	43	43		
			24	33	43	43	54	33	43	43	54	54	54	54	54		
		550S162	16	33	33	33	33	33	33	33	33	33	33	33	33		
			24	33	33	33	43	33	33	33	33	43	33	33	33	43	

For SI: 1 inch = 25.4 mm, 1 foot = 304.8 mm, 1 mil = 0.0254 mm, 1 mile per hour = 0.447 m/s, 1 pound per square foot = 0.0479 kPa, 1 ksi = 1000 psi = 6.895 MPa.

- a. Deflection criterion: $L/240$.
- b. Design load assumptions:
 Roof/ceiling dead load is 12 psf.
 Attic live load is 10 psf.
- c. Building width is in the direction of horizontal framing members supported by the wall studs.

TABLE R603.3.2(11)
40-FOOT-WIDE BUILDING SUPPORTING ROOF AND CEILING ONLY^{a, b, c}
50 ksi STEEL

WIND SPEED		MEMBER SIZE	STUD SPACING (inches)	MINIMUM STUD THICKNESS (mils)													
				8-Foot Studs				9-Foot Studs				10-Foot Studs					
Exp. A/B	Exp. C			Ground Snow Load (psf)													
				20	30	50	70	20	30	50	70	20	30	50	70		
85 mph	—	350S162	16	33	33	33	33	33	33	33	33	33	33	33	33	33	
			24	33	33	33	43	33	33	33	43	33	33	43	33	43	
		550S162	16	33	33	33	33	33	33	33	33	33	33	33	33	33	33
			24	33	33	33	33	33	33	33	33	33	33	33	33	33	33
90 mph	—	350S162	16	33	33	33	33	33	33	33	33	33	33	33	33	33	
			24	33	33	33	43	33	33	33	43	33	33	43	43		
		550S162	16	33	33	33	33	33	33	33	33	33	33	33	33	33	33
			24	33	33	33	33	33	33	33	33	33	33	33	33	33	33
100 mph	85 mph	350S162	16	33	33	33	33	33	33	33	33	33	33	33	33	33	
			24	33	33	33	43	33	33	33	43	33	33	43	43		
		550S162	16	33	33	33	33	33	33	33	33	33	33	33	33	33	33
			24	33	33	33	33	33	33	33	33	33	33	33	33	33	33
110 mph	90 mph	350S162	16	33	33	33	33	33	33	33	33	33	33	33	33	33	
			24	33	33	33	43	33	33	33	43	33	33	43	43		
		550S162	16	33	33	33	33	33	33	33	33	33	33	33	33	33	33
			24	33	33	33	33	33	33	33	33	33	33	33	33	33	33
—	100 mph	350S162	16	33	33	33	33	33	33	33	33	33	33	33	33	33	
			24	33	33	43	43	33	33	33	43	43	43	43	54		
		550S162	16	33	33	33	33	33	33	33	33	33	33	33	33	33	33
			24	33	33	33	33	33	33	33	33	33	33	33	33	33	33
—	110 mph	350S162	16	33	33	33	33	33	33	33	33	33	33	33	33	43	
			24	33	33	43	43	33	33	43	43	54	54	54	54		
		550S162	16	33	33	33	33	33	33	33	33	33	33	33	33	33	33
			24	33	33	33	33	33	33	33	33	33	33	33	33	33	33

For SI: 1 inch = 25.4 mm, 1 foot = 304.8 mm, 1 mil = 0.0254 mm, 1 mile per hour = 0.447 m/s, 1 pound per square foot = 0.0479 kPa, 1 ksi = 1000 psi = 6.895 MPa.

- a. Deflection criterion: $L/240$.
- b. Design load assumptions:
 Roof/ceiling dead load is 12 psf.
 Attic live load is 10 psf.
- c. Building width is in the direction of horizontal framing members supported by the wall studs.

TABLE R603.3.2(12)
24-FOOT-WIDE BUILDING SUPPORTING ONE FLOOR, ROOF AND CEILING^{a, b, c}
33 ksi STEEL

WIND SPEED		MEMBER SIZE	STUD SPACING (inches)	MINIMUM STUD THICKNESS (mils)													
Exp. A/B	Exp. C			8-Foot Studs				9-Foot Studs				10-Foot Studs					
				Ground Snow Load (psf)													
				20	30	50	70	20	30	50	70	20	30	50	70		
85 mph	—	350S162	16	33	33	33	33	33	33	33	33	33	33	33	33	33	
			24	33	33	33	43	33	33	33	43	43	43	43	43	43	
		550S162	16	33	33	33	33	33	33	33	33	33	33	33	33	33	33
			24	33	33	33	33	33	33	33	33	33	33	33	33	33	33
90 mph	—	350S162	16	33	33	33	33	33	33	33	33	33	33	33	33	33	
			24	33	33	33	43	33	33	33	43	43	43	43	43		
		550S162	16	33	33	33	33	33	33	33	33	33	33	33	33	33	
			24	33	33	33	33	33	33	33	33	33	33	33	33	33	
100 mph	85 mph	350S162	16	33	33	33	33	33	33	33	33	33	33	33	33	33	
			24	33	33	33	43	33	33	43	43	43	43	43	43		
		550S162	16	33	33	33	33	33	33	33	33	33	33	33	33	33	
			24	33	33	33	33	33	33	33	33	33	33	33	33	33	
110 mph	90 mph	350S162	16	33	33	33	33	33	33	33	33	33	33	33	33	33	
			24	33	33	43	43	43	43	43	43	43	43	43	43		
		550S162	16	33	33	33	33	33	33	33	33	33	33	33	33	33	
			24	33	33	33	33	33	33	33	33	33	33	33	33	33	
—	100 mph	350S162	16	33	33	33	33	33	33	33	33	33	33	33	43	43	
			24	43	43	43	43	43	43	43	43	43	43	43	54	54	
		550S162	16	33	33	33	33	33	33	33	33	33	33	33	33	33	
			24	33	33	33	33	33	33	33	33	33	33	33	33	33	
—	110 mph	350S162	16	33	33	33	33	33	33	33	33	33	43	43	43	43	
			24	43	43	43	43	43	43	43	43	43	54	54	54	54	
		550S162	16	33	33	33	33	33	33	33	33	33	33	33	33	33	
			24	33	33	33	33	33	33	33	33	33	33	33	33	43	

For SI: 1 inch = 25.4 mm, 1 foot = 304.8 mm, 1 mil = 0.0254 mm, 1 mile per hour = 0.447 m/s, 1 pound per square foot = 0.0479 kPa, 1 ksi = 1000 psi = 6.895 MPa.

a. Deflection criterion: $L/240$.

b. Design load assumptions:

Second floor dead load is 10 psf.

Second floor live load is 30 psf.

Roof/ceiling dead load is 12 psf.

Attic live load is 10 psf.

c. Building width is in the direction of horizontal framing members supported by the wall studs.

TABLE R603.3.2(13)
24-FOOT-WIDE BUILDING SUPPORTING ONE FLOOR, ROOF AND CEILING^{a, b, c}
50 ksi STEEL

WIND SPEED		MEMBER SIZE	STUD SPACING (inches)	MINIMUM STUD THICKNESS (mils)													
Exp. A/B	Exp. C			8-Foot Studs				9-Foot Studs				10-Foot Studs					
				Ground Snow Load (psf)													
				20	30	50	70	20	30	50	70	20	30	50	70		
85 mph	—	350S162	16	33	33	33	33	33	33	33	33	33	33	33	33	33	
			24	33	33	33	33	33	33	33	33	33	33	33	33	43	
		550S162	16	33	33	33	33	33	33	33	33	33	33	33	33	33	33
			24	33	33	33	33	33	33	33	33	33	33	33	33	33	33
90 mph	—	350S162	16	33	33	33	33	33	33	33	33	33	33	33	33	33	
			24	33	33	33	33	33	33	33	33	33	33	33	43		
		550S162	16	33	33	33	33	33	33	33	33	33	33	33	33	33	
			24	33	33	33	33	33	33	33	33	33	33	33	33	33	
100 mph	85 mph	350S162	16	33	33	33	33	33	33	33	33	33	33	33	33	33	
			24	33	33	33	33	33	33	33	33	33	33	33	43		
		550S162	16	33	33	33	33	33	33	33	33	33	33	33	33	33	
			24	33	33	33	33	33	33	33	33	33	33	33	33	33	
110 mph	90 mph	350S162	16	33	33	33	33	33	33	33	33	33	33	33	33	33	
			24	33	33	33	33	33	33	33	33	33	33	43	43		
		550S162	16	33	33	33	33	33	33	33	33	33	33	33	33	33	
			24	33	33	33	33	33	33	33	33	33	33	33	33	33	
—	100 mph	350S162	16	33	33	33	33	33	33	33	33	33	33	33	33	33	
			24	33	33	33	43	33	33	33	43	43	43	43	43		
		550S162	16	33	33	33	33	33	33	33	33	33	33	33	33	33	
			24	33	33	33	33	33	33	33	33	33	33	33	33	33	
—	110 mph	350S162	16	33	33	33	33	33	33	33	33	33	33	33	33	33	
			24	33	33	33	43	33	43	43	43	54	54	54	54		
		550S162	16	33	33	33	33	33	33	33	33	33	33	33	33	33	
			24	33	33	33	33	33	33	33	33	33	33	33	33	33	

For SI: 1 inch = 25.4 mm, 1 foot = 304.8 mm, 1 mil = 0.0254 mm, 1 mile per hour = 0.447 m/s, 1 pound per square foot = 0.0479 kPa, 1 ksi = 1000 psi = 6.895 MPa.

a. Deflection criterion: $L/240$.

b. Design load assumptions:

Second floor dead load is 10 psf.

Second floor live load is 30 psf.

Roof/ceiling dead load is 12 psf.

Attic live load is 10 psf.

c. Building width is in the direction of horizontal framing members supported by the wall studs.

TABLE R603.3.2(14)
28-FOOT-WIDE BUILDING SUPPORTING ONE FLOOR, ROOF AND CEILING^{a, b, c}
33 ksi STEEL

WIND SPEED		MEMBER SIZE	STUD SPACING (inches)	MINIMUM STUD THICKNESS (mils)													
Exp. A/B	Exp. C			8-Foot Studs				9-Foot Studs				10-Foot Studs					
				Ground Snow Load (psf)													
				20	30	50	70	20	30	50	70	20	30	50	70		
85 mph	—	350S162	16	33	33	33	33	33	33	33	33	33	33	33	33	33	
			24	33	43	43	43	33	33	43	43	43	43	43	43	43	
		550S162	16	33	33	33	33	33	33	33	33	33	33	33	33	33	33
			24	33	33	33	33	33	33	33	33	33	33	33	33	33	33
90 mph	—	350S162	16	33	33	33	33	33	33	33	33	33	33	33	33	33	
			24	33	43	43	43	33	33	43	43	43	43	43	43		
		550S162	16	33	33	33	33	33	33	33	33	33	33	33	33	33	
			24	33	33	33	33	33	33	33	33	33	33	33	33	33	
100 mph	85 mph	350S162	16	33	33	33	33	33	33	33	33	33	33	33	33	33	
			24	33	43	43	43	43	43	43	43	43	43	43	43		
		550S162	16	33	33	33	33	33	33	33	33	33	33	33	33	33	
			24	33	33	33	33	33	33	33	33	33	33	33	33	33	
110 mph	90 mph	350S162	16	33	33	33	33	33	33	33	33	33	33	33	33	33	
			24	43	43	43	43	43	43	43	43	43	43	43	54		
		550S162	16	33	33	33	33	33	33	33	33	33	33	33	33	33	
			24	33	33	33	33	33	33	33	33	33	33	33	33	33	
—	100 mph	350S162	16	33	33	33	33	33	33	33	33	33	43	43	43	43	
			24	43	43	43	43	43	43	43	43	43	54	54	54	54	
		550S162	16	33	33	33	33	33	33	33	33	33	33	33	33	33	
			24	33	33	33	33	33	33	33	33	33	33	33	33	43	
—	110 mph	350S162	16	33	33	33	33	33	33	33	33	43	43	43	43	43	
			24	43	43	43	43	43	43	43	54	54	54	54	54		
		550S162	16	33	33	33	33	33	33	33	33	33	33	33	33	33	
			24	33	33	33	33	33	33	33	33	33	33	33	43	43	

For SI: 1 inch = 25.4 mm, 1 foot = 304.8 mm, 1 mil = 0.0254 mm, 1 mile per hour = 0.447 m/s, 1 pound per square foot = 0.0479 kPa, 1 ksi = 1000 psi = 6.895 MPa.

a. Deflection criterion: $L/240$.

b. Design load assumptions:

Second floor dead load is 10 psf.

Second floor live load is 30 psf.

Roof/ceiling dead load is 12 psf.

Attic live load is 10 psf.

c. Building width is in the direction of horizontal framing members supported by the wall studs.

TABLE R603.3.2(15)
28-FOOT-WIDE BUILDING SUPPORTING ONE FLOOR, ROOF AND CEILING^{a, b, c}
50 ksi STEEL

WIND SPEED		MEMBER SIZE	STUD SPACING (inches)	MINIMUM STUD THICKNESS (mils)													
				8-Foot Studs				9-Foot Studs				10-Foot Studs					
Exp. A/B	Exp. C			Ground Snow Load (psf)													
				20	30	50	70	20	30	50	70	20	30	50	70		
85 mph	—	350S162	16	33	33	33	33	33	33	33	33	33	33	33	33	33	
			24	33	33	33	43	33	33	33	33	33	33	33	33	33	43
		550S162	16	33	33	33	33	33	33	33	33	33	33	33	33	33	33
			24	33	33	33	33	33	33	33	33	33	33	33	33	33	33
90 mph	—	350S162	16	33	33	33	33	33	33	33	33	33	33	33	33	33	
			24	33	33	33	43	33	33	33	33	33	33	33	33	43	
		550S162	16	33	33	33	33	33	33	33	33	33	33	33	33	33	33
			24	33	33	33	33	33	33	33	33	33	33	33	33	33	33
100 mph	85 mph	350S162	16	33	33	33	33	33	33	33	33	33	33	33	33	33	
			24	33	33	33	43	33	33	33	33	33	33	33	43	43	
		550S162	16	33	33	33	33	33	33	33	33	33	33	33	33	33	33
			24	33	33	33	33	33	33	33	33	33	33	33	33	33	33
110 mph	90 mph	350S162	16	33	33	33	33	33	33	33	33	33	33	33	33	33	
			24	33	33	33	43	33	33	33	43	43	43	43	43		
		550S162	16	33	33	33	33	33	33	33	33	33	33	33	33	33	33
			24	33	33	33	33	33	33	33	33	33	33	33	33	33	33
—	100 mph	350S162	16	33	33	33	33	33	33	33	33	33	33	33	33	33	
			24	33	33	43	43	33	33	43	43	43	43	43	43		
		550S162	16	33	33	33	33	33	33	33	33	33	33	33	33	33	
			24	33	33	33	33	33	33	33	33	33	33	33	33	33	
—	110 mph	350S162	16	33	33	33	33	33	33	33	33	33	33	33	33	43	
			24	33	43	43	43	43	43	43	43	54	54	54	54		
		550S162	16	33	33	33	33	33	33	33	33	33	33	33	33	33	
			24	33	33	33	33	33	33	33	33	33	33	33	33	33	

For SI: 1 inch = 25.4 mm, 1 foot = 304.8 mm, 1 mil = 0.0254 mm, 1 mile per hour = 0.447 m/s, 1 pound per square foot = 0.0479 kPa, 1 ksi = 1000 psi = 6.895 MPa.

a. Deflection criterion: $L/240$.

b. Design load assumptions:

Second floor dead load is 10 psf.

Second floor live load is 30 psf.

Roof/ceiling dead load is 12 psf.

Attic live load is 10 psf.

c. Building width is in the direction of horizontal framing members supported by the wall studs.

TABLE R603.3.2(16)
32-FOOT-WIDE BUILDING SUPPORTING ONE FLOOR, ROOF AND CEILING^{a, b, c}
33 ksi STEEL

WIND SPEED		MEMBER SIZE	STUD SPACING (inches)	MINIMUM STUD THICKNESS (mils)													
Exp. A/B	Exp. C			8-Foot Studs				9-Foot Studs				10-Foot Studs					
				Ground Snow Load (psf)													
				20	30	50	70	20	30	50	70	20	30	50	70		
85 mph	—	350S162	16	33	33	33	33	33	33	33	33	33	33	33	33	33	
			24	43	43	43	43	43	43	43	43	43	43	43	43	54	
		550S162	16	33	33	33	33	33	33	33	33	33	33	33	33	33	33
			24	33	33	33	43	33	33	33	33	33	33	33	33	33	43
90 mph	—	350S162	16	33	33	33	33	33	33	33	33	33	33	33	33	33	
			24	43	43	43	43	43	43	43	43	43	43	43	54		
		550S162	16	33	33	33	33	33	33	33	33	33	33	33	33	33	
			24	33	33	33	43	33	33	33	33	33	33	33	33	43	
100 mph	85 mph	350S162	16	33	33	33	33	33	33	33	33	33	33	33	33	43	
			24	43	43	43	43	43	43	43	43	43	43	43	54		
		550S162	16	33	33	33	33	33	33	33	33	33	33	33	33	33	
			24	33	33	33	43	33	33	33	33	33	33	33	33	43	
110 mph	90 mph	350S162	16	33	33	33	33	33	33	33	33	33	33	33	33	43	
			24	43	43	43	43	43	43	43	43	43	43	43	54		
		550S162	16	33	33	33	33	33	33	33	33	33	33	33	33	33	
			24	33	33	33	43	33	33	33	33	33	33	33	33	43	
—	100 mph	350S162	16	33	33	33	33	33	33	33	33	33	43	43	43	43	
			24	43	43	43	54	43	43	43	54	54	54	54	54		
		550S162	16	33	33	33	33	33	33	33	33	33	33	33	33	33	
			24	33	33	33	43	33	33	33	43	33	33	43	43	43	
—	110 mph	350S162	16	33	33	33	43	33	33	43	43	43	43	43	43		
			24	43	43	43	54	43	54	54	54	54	54	54	68		
		550S162	16	33	33	33	33	33	33	33	33	33	33	33	33		
			24	33	33	33	43	33	33	33	43	43	43	43	43		

For SI: 1 inch = 25.4 mm, 1 foot = 304.8 mm, 1 mil = 0.0254 mm, 1 mile per hour = 0.447 m/s, 1 pound per square foot = 0.0479 kPa, 1 ksi = 1000 psi = 6.895 MPa.

a. Deflection criterion: $L/240$.

b. Design load assumptions:

Second floor dead load is 10 psf.

Second floor live load is 30 psf.

Roof/ceiling dead load is 12 psf.

Attic live load is 10 psf.

c. Building width is in the direction of horizontal framing members supported by the wall studs.

TABLE R603.3.2(17)
32-FOOT-WIDE BUILDING SUPPORTING ONE FLOOR, ROOF AND CEILING^{a, b, c}
50 ksi STEEL

WIND SPEED		MEMBER SIZE	STUD SPACING (inches)	MINIMUM STUD THICKNESS (mils)													
				8-Foot Studs				9-Foot Studs				10-Foot Studs					
Exp. A/B	Exp. C			Ground Snow Load (psf)													
				20	30	50	70	20	30	50	70	20	30	50	70		
85 mph	—	350S162	16	33	33	33	33	33	33	33	33	33	33	33	33	33	
			24	33	43	43	43	33	33	33	43	33	33	43	43	43	
		550S162	16	33	33	33	33	33	33	33	33	33	33	33	33	33	33
			24	33	33	33	33	33	33	33	33	33	33	33	33	33	33
90 mph	—	350S162	16	33	33	33	33	33	33	33	33	33	33	33	33	33	
			24	33	43	43	43	33	33	33	43	33	33	43	43		
		550S162	16	33	33	33	33	33	33	33	33	33	33	33	33	33	
			24	33	33	33	33	33	33	33	33	33	33	33	33	33	
100 mph	85 mph	350S162	16	33	33	33	33	33	33	33	33	33	33	33	33	33	
			24	33	43	43	43	33	33	33	43	43	43	43	43		
		550S162	16	33	33	33	33	33	33	33	33	33	33	33	33	33	
			24	33	33	33	33	33	33	33	33	33	33	33	33	33	
110 mph	90 mph	350S162	16	33	33	33	33	33	33	33	33	33	33	33	33	33	
			24	33	43	43	43	33	33	33	43	43	43	43	54		
		550S162	16	33	33	33	33	33	33	33	33	33	33	33	33	33	
			24	33	33	33	33	33	33	33	33	33	33	33	33	33	
—	100 mph	350S162	16	33	33	33	33	33	33	33	33	33	33	33	33	33	
			24	33	43	43	43	43	43	43	43	43	43	43	54		
		550S162	16	33	33	33	33	33	33	33	33	33	33	33	33	33	
			24	33	33	33	33	33	33	33	33	33	33	33	33	33	
—	110 mph	350S162	16	33	33	33	33	33	33	33	33	33	33	33	33	43	
			24	43	43	43	43	43	43	43	43	54	54	54	54		
		550S162	16	33	33	33	33	33	33	33	33	33	33	33	33	33	
			24	33	33	33	33	33	33	33	33	33	33	33	33	33	

For SI: 1 inch = 25.4 mm, 1 foot = 304.8 mm, 1 mil = 0.0254 mm, 1 mile per hour = 0.447 m/s, 1 pound per square foot = 0.0479 kPa, 1 ksi = 1000 psi = 6.895 MPa.

a. Deflection criterion: $L/240$.

b. Design load assumptions:

Second floor dead load is 10 psf.

Second floor live load is 30 psf.

Roof/ceiling dead load is 12 psf.

Attic live load is 10 psf.

c. Building width is in the direction of horizontal framing members supported by the wall studs.

TABLE R603.3.2(18)
36-FOOT-WIDE BUILDING SUPPORTING ONE FLOOR, ROOF AND CEILING^{a, b, c}
33 ksi STEEL

WIND SPEED		MEMBER SIZE	STUD SPACING (inches)	MINIMUM STUD THICKNESS (mils)													
Exp. A/B	Exp. C			8-Foot Studs				9-Foot Studs				10-Foot Studs					
				Ground Snow Load (psf)													
				20	30	50	70	20	30	50	70	20	30	50	70		
85 mph	—	350S162	16	33	33	33	33	33	33	33	33	33	33	33	33	43	
			24	43	43	43	54	43	43	43	43	43	43	43	43	43	54
		550S162	16	33	33	33	33	33	33	33	33	33	33	33	33	33	33
			24	43	43	43	43	33	33	33	43	33	33	33	33	33	43
90 mph	—	350S162	16	33	33	33	33	33	33	33	33	33	33	33	33	43	
			24	43	43	43	54	43	43	43	43	43	43	43	43	54	
		550S162	16	33	33	33	33	33	33	33	33	33	33	33	33	33	
			24	43	43	43	43	33	33	33	43	33	33	43	43	43	
100 mph	85 mph	350S162	16	33	33	33	33	33	33	33	33	33	33	33	33	43	
			24	43	43	43	54	43	43	43	54	43	43	54	54		
		550S162	16	33	33	33	33	33	33	33	33	33	33	33	33	33	
			24	43	43	43	43	33	33	33	43	33	33	43	43	43	
110 mph	90 mph	350S162	16	33	33	33	43	33	33	33	33	33	33	33	43	43	
			24	43	43	43	54	43	43	43	54	43	43	54	54		
		550S162	16	33	33	33	33	33	33	33	33	33	33	33	33	33	
			24	43	43	43	43	33	33	33	43	33	33	43	43	43	
—	100 mph	350S162	16	33	33	33	43	33	33	43	43	43	43	43	43		
			24	43	43	43	54	43	43	54	54	54	54	54	54		
		550S162	16	33	33	33	33	33	33	33	33	33	33	33	33		
			24	43	43	43	43	33	33	33	43	43	43	43	43		
—	110 mph	350S162	16	33	33	33	43	33	33	43	43	43	43	43	43		
			24	43	43	43	54	43	54	54	54	54	54	54	68		
		550S162	16	33	33	33	33	33	33	33	33	33	33	33	33		
			24	33	33	33	43	33	33	33	43	43	43	43	43		

For SI: 1 inch = 25.4 mm, 1 foot = 304.8 mm, 1 mil = 0.0254 mm, 1 mile per hour = 0.447 m/s, 1 pound per square foot = 0.0479 kPa, 1 ksi = 1000 psi = 6.895 MPa.

- a. Deflection criterion: $L/240$.
- b. Design load assumptions:
 - Second floor dead load is 10 psf.
 - Second floor live load is 30 psf.
 - Roof/ceiling dead load is 12 psf.
 - Attic live load is 10 psf.
- c. Building width is in the direction of horizontal framing members supported by the wall studs.

TABLE R603.3.2(19)
36-FOOT-WIDE BUILDING SUPPORTING ONE FLOOR, ROOF AND CEILING^{a, b, c}
50 ksi STEEL

WIND SPEED		MEMBER SIZE	STUD SPACING (inches)	MINIMUM STUD THICKNESS (mils)													
				8-Foot Studs				9-Foot Studs				10-Foot Studs					
Exp. A/B	Exp. C			Ground Snow Load (psf)													
				20	30	50	70	20	30	50	70	20	30	50	70		
85 mph	—	350S162	16	33	33	33	33	33	33	33	33	33	33	33	33	33	
			24	43	43	43	43	33	33	43	43	43	43	43	43	43	
		550S162	16	33	33	33	33	33	33	33	33	33	33	33	33	33	33
			24	33	33	33	43	33	33	33	33	33	33	33	33	33	33
90 mph	—	350S162	16	33	33	33	33	33	33	33	33	33	33	33	33	33	
			24	43	43	43	43	33	33	43	43	43	43	43	43		
		550S162	16	33	33	33	33	33	33	33	33	33	33	33	33	33	
			24	33	43	33	43	33	33	33	33	33	33	33	33	33	
100 mph	85 mph	350S162	16	33	33	33	33	33	33	33	33	33	33	33	33	33	
			24	43	43	43	43	33	33	43	43	43	43	43	43		
		550S162	16	33	33	33	33	33	33	33	33	33	33	33	33	33	
			24	33	33	33	43	33	33	33	33	33	33	33	33	33	
110 mph	90 mph	350S162	16	33	33	33	33	33	33	33	33	33	33	33	33	33	
			24	43	43	43	43	33	33	43	43	43	43	43	54		
		550S162	16	33	33	33	33	33	33	33	33	33	33	33	33	33	
			24	43	33	33	43	33	33	33	33	33	33	33	33	33	
—	100 mph	350S162	16	33	33	33	33	33	33	33	33	33	33	33	33	43	
			24	43	43	43	43	43	43	43	43	43	43	43	54	54	
		550S162	16	33	33	33	33	33	33	33	33	33	33	33	33	33	
			24	33	33	33	43	33	33	33	33	33	33	33	33	43	
—	110 mph	350S162	16	33	33	33	33	33	33	33	33	33	33	33	43	43	
			24	43	43	43	54	43	43	43	43	43	54	54	54		
		550S162	16	33	33	33	33	33	33	33	33	33	33	33	33	33	
			24	33	33	33	33	33	33	33	33	33	33	33	33	43	

For SI: 1 inch = 25.4 mm, 1 foot = 304.8 mm, 1 mil = 0.0254 mm, 1 mile per hour = 0.447 m/s 1 pound per square foot = 0.0479 kPa, 1 ksi = 1000 psi = 6.895 MPa.

- a. Deflection criterion: $L/240$.
- b. Design load assumptions:
 - Second floor dead load is 10 psf.
 - Second floor live load is 30 psf.
 - Roof/ceiling dead load is 12 psf.
 - Attic live load is 10 psf.
- c. Building width is in the direction of horizontal framing members supported by the wall studs.

TABLE R603.3.2(20)
40-FOOT-WIDE BUILDING SUPPORTING ONE FLOOR, ROOF AND CEILING^{a, b, c}
33 ksi STEEL

WIND SPEED		MEMBER SIZE	STUD SPACING (inches)	MINIMUM STUD THICKNESS (mils)												
Exp. A/B	Exp. C			8-Foot Studs				9-Foot Studs				10-Foot Studs				
				Ground Snow Load (psf)												
				20	30	50	70	20	30	50	70	20	30	50	70	
85 mph	—	350S162	16	33	33	33	43	33	33	33	43	33	33	33	43	
			24	43	54	54	54	43	43	43	54	43	43	54	54	
		550S162	16	33	33	33	33	33	33	33	33	33	33	33	33	33
			24	43	43	43	43	43	43	43	43	43	33	43	43	43
90 mph	—	350S162	16	33	33	33	43	33	33	33	43	33	33	33	43	
			24	43	54	54	54	43	43	43	54	43	43	54	54	
		550S162	16	33	33	33	33	33	33	33	33	33	33	33	33	
			24	43	43	43	43	43	43	43	43	33	43	43	43	
100 mph	85 mph	350S162	16	33	33	33	43	33	33	33	43	33	33	43	43	
			24	43	54	54	54	43	43	43	54	43	43	54	54	
		550S162	16	33	33	33	33	33	33	33	33	33	33	33	33	
			24	43	43	43	43	43	43	43	43	33	43	43	43	
110 mph	90 mph	350S162	16	33	33	33	43	33	33	33	43	33	43	43	43	
			24	43	54	54	54	43	43	43	54	43	54	54		
		550S162	16	33	33	33	33	33	33	33	33	33	33	33	33	
			24	43	43	43	43	43	43	43	43	33	43	43	43	
—	100 mph	350S162	16	33	33	33	43	33	33	43	43	33	43	43	43	
			24	43	54	54	54	54	54	54	54	43	54	54	68	
		550S162	16	33	33	33	33	33	33	33	33	33	33	33	33	
			24	43	43	43	43	43	43	43	43	33	43	43	43	
—	110 mph	350S162	16	33	33	43	43	43	43	43	43	33	43	43	43	
			24	54	54	54	54	54	54	54	54	54	68	68	68	
		550S162	16	33	33	33	33	33	33	33	33	33	33	33	33	
			24	43	43	43	43	43	43	43	43	33	43	43	43	

For SI: 1 inch = 25.4 mm, 1 foot = 304.8 mm, 1 mil = 0.0254 mm, 1 mile per hour = 0.447 m/s, 1 pound per square foot = 0.0479 kPa, 1 ksi = 1000 psi = 6.895 MPa.

- a. Deflection criterion: $L/240$.
- b. Design load assumptions:
 - Second floor dead load is 10 psf.
 - Second floor live load is 30 psf.
 - Roof/ceiling dead load is 12 psf.
 - Attic live load is 10 psf.
- c. Building width is in the direction of horizontal framing members supported by the wall studs.

TABLE R603.3.2(21)
40-FOOT-WIDE BUILDING SUPPORTING ONE FLOOR, ROOF AND CEILING^{a, b, c}
50 ksi STEEL

WIND SPEED		MEMBER SIZE	STUD SPACING (inches)	MINIMUM STUD THICKNESS (mils)													
				8-Foot Studs				9-Foot Studs				10-Foot Studs					
Exp. A/B	Exp. C			Ground Snow Load (psf)													
				20	30	50	70	20	30	50	70	20	30	50	70		
85 mph	—	350S162	16	33	33	33	33	33	33	33	33	33	33	33	33	33	
			24	43	43	43	54	43	43	43	43	43	43	43	43	43	54
		550S162	16	33	33	33	33	33	33	33	33	33	33	33	33	33	33
			24	33	33	43	43	33	33	33	33	33	33	33	33	33	43
90 mph	—	350S162	16	33	33	33	33	33	33	33	33	33	33	33	33	33	
			24	43	43	43	54	43	43	43	43	43	43	43	43	54	
		550S162	16	33	33	33	33	33	33	33	33	33	33	33	33	33	
			24	33	33	43	43	33	33	33	33	33	33	33	33	33	43
100 mph	85 mph	350S162	16	33	33	33	33	33	33	33	33	33	33	33	33	33	
			24	43	43	43	54	43	43	43	43	43	43	43	43	54	
		550S162	16	33	33	33	33	33	33	33	33	33	33	33	33	33	
			24	33	33	43	43	33	33	33	33	33	33	33	33	33	43
110 mph	90 mph	350S162	16	33	33	33	33	33	33	33	33	33	33	33	33	33	
			24	43	43	43	54	43	43	43	43	43	43	43	43	54	
		550S162	16	33	33	33	33	33	33	33	33	33	33	33	33	33	
			24	33	33	43	43	33	33	33	33	33	33	33	33	33	43
—	100 mph	350S162	16	33	33	33	33	33	33	33	33	33	33	33	33	33	
			24	43	43	43	54	43	43	43	43	43	43	54	54	54	
		550S162	16	33	33	33	33	33	33	33	33	33	33	33	33	33	
			24	33	33	43	43	33	33	33	33	33	33	33	33	33	43
—	110 mph	350S162	16	33	33	33	43	33	33	33	43	33	43	43	43		
			24	43	43	43	54	43	43	43	54	54	54	54	54		
		550S162	16	33	33	33	33	33	33	33	33	33	33	33	33		
			24	33	33	43	43	33	33	43	43	33	33	33	43	43	

For SI: 1 inch = 25.4 mm, 1 foot = 304.8 mm, 1 mil = 0.0254 mm, 1 mile per hour = 0.447 m/s, 1 pound per square foot = 0.0479 kPa, 1 ksi = 1000 psi = 6.895 MPa.

a. Deflection criterion: $L/240$.

b. Design load assumptions:

Second floor dead load is 10 psf.

Second floor live load is 30 psf.

Roof/ceiling dead load is 12 psf.

Attic live load is 10 psf.

c. Building width is in the direction of horizontal framing members supported by the wall studs.

TABLE R603.6(1)
BOX-BEAM HEADER SPANS
Headers supporting roof and ceiling only (33 ksi steel)^{a, b, c}

MEMBER DESIGNATION	GROUND SNOW LOAD (20 psf)					GROUND SNOW LOAD (30 psf)				
	Building width ^c					Building width ^c				
	24'	28'	32'	36'	40'	24'	28'	32'	36'	40'
2-350S162-33	3'-10"	3'-5"	3'-0"	2'-6"	2'-2"	3'-3"	2'-9"	2'-4"	—	—
2-350S162-43	5'-1"	4'-8"	4'-4"	4'-0"	3'-7"	4'-6"	4'-2"	3'-8"	3'-4"	2'-11"
2-350S162-54	5'-9"	5'-4"	5'-0"	4'-9"	4'-5"	5'-3"	4'-10"	4'-6"	4'-2"	3'-10"
2-350S162-68	6'-7"	6'-1"	5'-9"	5'-5"	5'-1"	6'-0"	5'-6"	5'-2"	4'-10"	4'-7"
2-350S162-97	8'-0"	7'-5"	7'-0"	6'-6"	6'-3"	7'-3"	6'-9"	6'-4"	6'-0"	5'-7"
2-550S162-33	5'-8"	5'-0"	4'-5"	3'-11"	3'-4"	4'-9"	4'-1"	3'-6"	2'-11"	—
2-550S162-43	7'-2"	6'-8"	6'-3"	5'-8"	5'-2"	6'-6"	5'-11"	5'-3"	4'-9"	4'-3"
2-550S162-54	8'-2"	7'-7"	7'-2"	6'-9"	6'-5"	7'-5"	6'-11"	6'-6"	6'-0"	5'-6"
2-550S162-68	9'-3"	8'-7"	8'-0"	7'-8"	7'-3"	8'-5"	7'-10"	7'-4"	7'-0"	6'-7"
2-550S162-97	11'-2"	10'-5"	9'-10"	9'-3"	8'-11"	10'-2"	9'-6"	9'-1"	8'-5"	8'-0"
2-800S162-33	6'-9"	5'-11"	5'-2"	4'-6"	3'-10"	5'-6"	4'-6"	4'-0"	—	—
2-800S162-43	9'-0"	8'-5"	7'-8"	7'-0"	6'-4"	8'-1"	7'-3"	6'-6"	5'-9"	5'-2"
2-800S162-54	10'-9"	10'-0"	9'-5"	8'-11"	8'-4"	9'-9"	9'-1"	8'-6"	7'-9"	7'-1"
2-800S162-68	12'-2"	11'-4"	10'-8"	10'-2"	9'-7"	11'-1"	10'-4"	9'-9"	9'-3"	8'-9"
2-800S162-97	14'-9"	13'-9"	13'-0"	12'-3"	11'-7"	13'-5"	12'-6"	11'-10"	11'-2"	10'-7"
2-1000S162-43	10'-0"	9'-2"	8'-4"	7'-6"	6'-9"	8'-9"	7'-10"	7'-0"	6'-2"	5'-5"
2-1000S162-54	12'-0"	11'-2"	10'-6"	9'-11"	9'-2"	10'-11"	10'-2"	9'-3"	8'-6"	7'-9"
2-1000S162-68	14'-5"	13'-6"	12'-8"	12'-0"	11'-5"	13'-2"	12'-3"	11'-6"	11'-0"	10'-4"
2-1000S162-97	17'-5"	16'-4"	15'-4"	14'-6"	13'-11"	16'-0"	14'-11"	14'-0"	13'-3"	12'-7"
2-1200S162-43	10'-10"	9'-9"	8'-9"	7'-11"	7'-1"	9'-3"	8'-2"	7'-2"	6'-4"	5'-6"
2-1200S162-54	13'-0"	12'-2"	11'-6"	10'-7"	9'-9"	11'-11"	11'-0"	10'-0"	9'-0"	8'-2"
2-1200S162-68	15'-5"	14'-5"	13'-6"	12'-11"	12'-3"	14'-0"	13'-2"	12'-4"	11'-9"	10'-11"
2-1200S162-97	20'-1"	18'-9"	17'-9"	16'-9"	16'-0"	18'-4"	17'-2"	16'-2"	15'-3"	14'-7"

For SI: 1 inch = 25.4 mm, 1 foot = 304.8 mm, 1 pound per square foot = 0.0479 kPa, 1 pound per square inch = 6.895 kPa.

a. Deflection criteria: *L*/360 for live loads, *L*/240 for total loads.

b. Design load assumptions:

Roof/Ceiling dead load is 12 psf.

Attic dead load is 10 psf.

c. Building width is in the direction of horizontal framing members supported by the header

TABLE R603.6(2)
BOX-BEAM HEADER SPANS
Headers supporting roof and ceiling only (33 ksi steel)^{a, b, c}

MEMBER DESIGNATION	GROUND SNOW LOAD (50 psf)					GROUND SNOW LOAD (70 psf)				
	Building width ^c					Building width ^c				
	24'	28'	32'	36'	40'	24'	28'	32'	36'	40'
2-350S162-33	—	—	—	—	—	—	—	—	—	—
2-350S162-43	3'-2"	2'-7"	2'-2"	—	—	2'-0"	—	—	—	—
2-350S162-54	4'-1"	3'-6"	3'-1"	2'-8"	2'-3"	3'-0"	2'-6"	—	—	—
2-350S162-68	4'-9"	4'-5"	4'-0"	3'-7"	3'-3"	4'-0"	3'-4"	3'-0"	2'-6"	2'-1"
2-350S162-97	5'-10"	5'-5"	5'-1"	4'-9"	4'-6"	5'-0"	4'-7"	4'-4"	4'-0"	3'-9"
2-550S162-33	2'-9"	—	—	—	—	—	—	—	—	—
2-550S162-43	4'-7"	3'-11"	3'-3"	—	—	3'-2"	—	—	—	—
2-550S162-54	5'-10"	5'-2"	4'-6"	4'-0"	3'-6"	4'-5"	3'-9"	3'-1"	—	—
2-550S162-68	6'-10"	6'-4"	5'-9"	5'-3"	4'-9"	5'-7"	5'-0"	4'-4"	3'-9"	3'-3"
2-550S162-97	8'-4"	7'-9"	7'-3"	6'-10"	6'-6"	7'-2"	6'-8"	6'-3"	5'-11"	5'-7"
2-800S162-33	—	—	—	—	—	—	—	—	—	—
2-800S162-43	5'-7"	4'-9"	3'-11"	—	—	—	—	—	—	—
2-800S162-54	7'-7"	6'-8"	5'-11"	5'-2"	4'-6"	5'-9"	4'-10"	—	—	—
2-800S162-68	9'-1"	8'-4"	7'-6"	6'-10"	6'-3"	7'-4"	6'-6"	5'-9"	5'-0"	4'-4"
2-800S162-97	11'-0"	10'-4"	9'-8"	9'-2"	8'-9"	9'-6"	8'-11"	8'-4"	7'-11"	7'-6"
2-1000S162-43	6'-0"	4'-11"	—	—	—	—	—	—	—	—
2-1000S162-54	8'-4"	7'-4"	6'-4"	5'-7"	4'-9"	6'-3"	5'-2"	—	—	—
2-1000S162-68	10'-9"	9'-9"	8'-10"	8'-0"	7'-3"	8'-7"	7'-7"	6'-7"	5'-9"	5'-0"
2-1000S162-97	13'-1"	12'-3"	11'-6"	10'-11"	10'-4"	11'-4"	10'-7"	10'-0"	9'-5"	8'-11"
2-1200S162-43	6'-1"	—	—	—	—	—	—	—	—	—
2-1200S162-54	8'-9"	7'-8"	6'-7"	5'-9"	—	6'-6"	—	—	—	—
2-1200S162-68	11'-6"	10'-4"	9'-4"	8'-4"	7'-7"	9'-1"	8'-0"	6'-11"	6'-0"	—
2-1200S162-97	15'-1"	14'-1"	13'-3"	12'-7"	12'-0"	13'-1"	12'-3"	11'-6"	11'-0"	10'-2"

For SI: 1 inch = 25.4 mm, 1 foot = 304.8 mm, 1 pound per square foot = 0.0479 kPa, 1 pound per square inch = 6.895 kPa.

a. Deflection criteria: $L/360$ for live loads, $L/240$ for total loads.

b. Design load assumptions:

Roof/Ceiling dead load is 12 psf.

Attic dead load is 10 psf.

c. Building width is in the direction of horizontal framing members supported by the header

TABLE R603.6(3)
BOX-BEAM HEADER SPANS
Headers supporting one floor, roof and ceiling (33 ksi steel)^{a, b, c}

MEMBER DESIGNATION	GROUND SNOW LOAD (20 psf)					GROUND SNOW LOAD (30 psf)				
	Building width ^c					Building width ^c				
	24'	28'	32'	36'	40'	24'	28'	32'	36'	40'
2-350S162-33	—	—	—	—	—	—	—	—	—	—
2-350S162-43	2'-6"	—	—	—	—	2'-5"	—	—	—	—
2-350S162-54	3'-6"	3'-0"	2'-6"	—	—	3'-4"	2'-10"	2'-4"	—	—
2-350S162-68	4'-4"	3'-11"	3'-5"	3'-0"	2'-7"	4'-3"	3'-9"	3'-3"	2'-10"	2'-6"
2-350S162-97	5'-4"	5'-0"	4'-7"	4'-4"	4'-1"	5'-4"	4'-11"	4'-6"	4'-3"	4'-0"
2-550S162-33	—	—	—	—	—	—	—	—	—	—
2-550S162-43	3'-9"	3'-0"	—	—	—	3'-7"	2'-11"	—	—	—
2-550S162-54	5'-0"	4'-4"	3'-9"	3'-2"	—	4'-10"	4'-2"	3'-6"	3'-0"	—
2-550S162-68	6'-3"	5'-6"	5'-0"	4'-5"	4'-0"	6'-1"	5'-5"	4'-9"	4'-3"	3'-9"
2-550S162-97	7'-8"	7'-2"	6'-8"	6'-4"	6'-0"	7'-6"	7'-0"	6'-6"	6'-2"	5'-10"
2-800S162-33	—	—	—	—	—	—	—	—	—	—
2-800S162-43	4'-6"	—	—	—	—	4'-4"	—	—	—	—
2-800S162-54	6'-6"	5'-7"	4'-10"	4'-1"	—	6'-4"	5'-5"	4'-7"	—	—
2-800S162-68	8'-2"	7'-3"	6'-6"	5'-10"	5'-2"	8'-0"	7'-0"	6'-4"	5'-6"	5'-0"
2-800S162-97	10'-1"	9'-6"	8'-11"	8'-6"	8'-0"	10'-0"	9'-4"	8'-9"	8'-3"	7'-11"
2-1000S162-43	4'-9"	—	—	—	—	—	—	—	—	—
2-1000S162-54	7'-1"	6'-0"	5'-2"	—	—	6'-10"	5'-10"	4'-11"	—	—
2-1000S162-68	9'-7"	8'-6"	7'-7"	6'-9"	6'-0"	9'-4"	8'-4"	7'-4"	6'-6"	5'-9"
2-1000S162-97	12'-0"	11'-3"	10'-7"	10'-0"	9'-6"	11'-11"	11'-1"	10'-5"	9'-11"	9'-5"
2-1200S162-43	—	—	—	—	—	—	—	—	—	—
2-1200S162-54	7'-6"	6'-4"	—	—	—	7'-2"	6'-0"	—	—	—
2-1200S162-68	10'-1"	9'-0"	8'-0"	7'-0"	6'-2"	9'-11"	8'-9"	7'-9"	6'-9"	6'-0"
2-1200S162-97	14'-0"	13'-0"	12'-3"	11'-7"	11'-0"	13'-9"	12'-10"	12'-0"	11'-6"	10'-11"

For SI: 1 inch = 25.4 mm, 1 foot = 304.8 mm, 1 pound per square foot = 0.0479 kPa, 1 pound per square inch = 6.895 kPa.

a. Deflection criteria: $L/360$ for live loads, $L/240$ for total loads.

b. Design load assumptions:

Roof/Ceiling dead load is 12 psf.

Attic dead load is 10 psf.

c. Building width is in the direction of horizontal framing members supported by the header

TABLE R603.6(4)
BOX-BEAM HEADER SPANS
Headers supporting one floor, roof and ceiling (33 ksi steel)^{a, b, c}

MEMBER DESIGNATION	GROUND SNOW LOAD (50 psf)					GROUND SNOW LOAD (70 psf)				
	Building width ^c					Building width ^c				
	24'	28'	32'	36'	40'	24'	28'	32'	36'	40'
2-350S162-33	—	—	—	—	—	—	—	—	—	—
2-350S162-43	—	—	—	—	—	—	—	—	—	—
2-350S162-54	2'-6"	2'-1"	—	—	—	—	—	—	—	—
2-350S162-68	3'-6"	3'-0"	2'-6"	2'-2"	—	2'-9"	2'-2"	—	—	—
2-350S162-97	4'-9"	4'-5"	4'-1"	3'-10"	3'-7"	4'-2"	3'-11"	3'-7"	3'-4"	2'-11"
2-550S162-33	—	—	—	—	—	—	—	—	—	—
2-550S162-43	—	—	—	—	—	—	—	—	—	—
2-550S162-54	3'-11"	3'-4"	—	—	—	2'-10"	—	—	—	—
2-550S162-68	5'-2"	4'-6"	3'-11"	3'-4"	2'-10"	4'-1"	3'-5"	2'-9"	—	—
2-550S162-97	6'-10"	6'-4"	6'-0"	5'-7"	5'-4"	6'-1"	5'-7"	5'-4"	4'-9"	4'-4"
2-800S162-33	—	—	—	—	—	—	—	—	—	—
2-800S162-43	—	—	—	—	—	—	—	—	—	—
2-800S162-54	5'-1"	4'-2"	—	—	—	—	—	—	—	—
2-800S162-68	6'-9"	6'-1"	5'-2"	4'-5"	—	5'-5"	4'-6"	—	—	—
2-800S162-97	9'-1"	8'-6"	8'-0"	7'-6"	7'-1"	8'-2"	7'-7"	7'-0"	6'-5"	5'-10"
2-1000S162-43	—	—	—	—	—	—	—	—	—	—
2-1000S162-54	5'-6"	—	—	—	—	—	—	—	—	—
2-1000S162-68	7'-10"	6'-11"	6'-0"	5'-2"	—	6'-4"	5'-4"	—	—	—
2-1000S162-97	10'-10"	10'-1"	9'-6"	9'-0"	8'-4"	9'-9"	9'-2"	8'-4"	7'-7"	7'-0"
2-1200S162-43	—	—	—	—	—	—	—	—	—	—
2-1200S162-54	5'-7"	—	—	—	—	—	—	—	—	—
2-1200S162-68	8'-4"	7'-2"	6'-2"	—	—	6'-6"	—	—	—	—
2-1200S162-97	12'-6"	11'-8"	11'-0"	10'-4"	9'-6"	11'-3"	10'-6"	9'-6"	8'-8"	8'-0"

For SI: 1 inch = 25.4 mm, 1 foot = 304.8 mm, 1 pound per square foot = 0.0479 kPa, 1 pound per square inch = 6.895 kPa.

a. Deflection criteria: $L/360$ for live loads, $L/240$ for total loads.

b. Design load assumptions:

Roof/Ceiling dead load is 12 psf.

Attic dead load is 10 psf.

c. Building width is in the direction of horizontal framing members supported by the header.

TABLE R603.6(5)
BACK-TO-BACK HEADER SPANS
Headers supporting roof and ceiling only (33 ksi steel)^{a, b, c}

MEMBER DESIGNATION	GROUND SNOW LOAD (20 psf)					GROUND SNOW LOAD (30 psf)				
	Building width ^c					Building width ^c				
	24'	28'	32'	36'	40'	24'	28'	32'	36'	40'
2-350S162-33	3'-7"	3'-1"	2'-8"	2'-4"	—	2'-11"	2'-6"	—	—	—
2-350S162-43	5'-0"	4'-8"	4'-4"	3'-10"	3'-7"	4'-6"	4'-0"	3'-8"	3'-4"	2'-11"
2-350S162-54	5'-9"	5'-5"	5'-0"	4'-9"	4'-6"	5'-3"	4'-10"	4'-6"	4'-4"	3'-11"
2-350S162-68	6'-7"	6'-2"	5'-9"	5'-5"	5'-2"	5'-11"	5'-7"	5'-2"	4'-10"	4'-7"
2-350S162-97	7'-11"	7'-6"	6'-11"	6'-7"	6'-6"	7'-4"	6'-9"	6'-4"	5'-11"	5'-8"
2-550S162-33	5'-5"	4'-9"	4'-4"	3'-9"	3'-5"	4'-7"	3'-11"	3'-5"	2'-11"	—
2-550S162-43	7'-3"	6'-8"	6'-2"	5'-8"	5'-4"	6'-6"	5'-10"	5'-5"	4'-10"	4'-6"
2-550S162-54	8'-2"	7'-8"	7'-2"	6'-9"	6'-5"	7'-5"	6'-10"	6'-6"	6'-1"	5'-9"
2-550S162-68	9'-4"	8'-8"	8'-7"	7'-8"	7'-4"	8'-6"	7'-10"	7'-5"	6'-11"	6'-7"
2-550S162-97	11'-3"	10'-6"	9'-11"	9'-4"	8'-10"	10'-3"	9'-6"	8'-11"	8'-6"	8'-0"
2-800S162-33	6'-9"	5'-11"	5'-5"	4'-9"	4'-4"	6'-9"	5'-0"	4'-5"	3'-9"	—
2-800S162-43	9'-1"	8'-6"	7'-9"	7'-3"	6'-8"	8'-3"	7'-6"	6'-9"	6'-3"	5'-8"
2-800S162-54	10'-9"	10'-1"	9'-6"	8'-11"	8'-6"	9'-9"	9'-2"	8'-7"	8'-2"	7'-8"
2-800S162-68	12'-3"	11'-5"	10'-9"	10'-2"	9'-8"	11'-2"	10'-5"	9'-9"	9'-4"	8'-9"
2-800S162-97	14'-9"	13'-9"	13'-0"	12'-4"	11'-8"	13'-6"	12'-7"	11'-10"	11'-2"	10'-8"
2-1000S162-43	10'-1"	9'-5"	8'-8"	8'-0"	7'-6"	9'-1"	8'-4"	7'-7"	6'-11"	6'-5"
2-1000S162-54	12'-0"	11'-5"	10'-7"	10'-0"	9'-6"	11'-0"	10'-3"	9'-7"	9'-1"	8'-6"
2-1000S162-68	14'-6"	13'-6"	12'-8"	12'-0"	11'-6"	13'-2"	12'-4"	11'-7"	10'-11"	10'-6"
2-1000S162-97	17'-6"	16'-5"	15'-5"	14'-7"	13'-10"	16'-0"	14'-10"	14'-0"	13'-4"	12'-8"
2-1200S162-43	11'-0"	10'-4"	9'-6"	8'-9"	8'-2"	10'-0"	9'-1"	8'-4"	7'-7"	7'-0"
2-1200S162-54	13'-1"	12'-3"	11'-6"	10'-10"	10'-5"	11'-10"	11'-1"	10'-6"	9'-10"	9'-4"
2-1200S162-68	15'-6"	14'-6"	13'-7"	12'-10"	12'-3"	14'-1"	13'-2"	12'-5"	11'-9"	11'-2"
2-1200S162-97	20'-2"	18'-9"	17'-9"	16'-9"	16'-0"	18'-4"	17'-2"	16'-2"	15'-5"	14'-7"

For SI: 1 inch = 25.4 mm, 1 foot = 304.8 mm, 1 pound per square foot = 0.0479 kPa, 1 pound per square inch = 6.895 kPa.

a. Deflection criteria: *L*/360 for live loads, *L*/240 for total loads.

b. Design load assumptions:

Roof/Ceiling dead load is 12 psf.

Attic dead load is 10 psf.

c. Building width is in the direction of horizontal framing members supported by the header.

TABLE R603.6(6)
BACK-TO-BACK HEADER SPANS
Headers supporting roof and ceiling only (33 ksi steel)^{a, b, c}

MEMBER DESIGNATION	GROUND SNOW LOAD (50 psf)					GROUND SNOW LOAD (70 psf)				
	Building width ^c					Building width ^c				
	24'	28'	32'	36'	40'	24'	28'	32'	36'	40'
2-350S162-33	—	—	—	—	—	—	—	—	—	—
2-350S162-43	3'-2"	2'-8"	2'-4"	—	—	2'-3"	—	—	—	—
2-350S162-54	4'-3"	3'-8"	3'-5"	2'-11"	2'-8"	3'-4"	2'-9"	2'-5"	2'-0"	1'-7"
2-350S162-68	4'-9"	4'-6"	4'-2"	3'-10"	3'-7"	4'-1"	3'-9"	3'-5"	3'-1"	2'-8"
2-350S162-97	5'-10"	5'-6"	5'-2"	4'-10"	4'-7"	5'-0"	4'-8"	4'-5"	4'-2"	3'-10"
2-550S162-33	2'-9"	—	—	—	—	—	—	—	—	—
2-550S162-43	4'-9"	4'-2"	3'-8"	3'-3"	2'-8"	3'-6"	2'-10"	—	—	—
2-550S162-54	6'-0"	5'-6"	4'-11"	4'-6"	4'-1"	4'-10"	4'-4"	3'-10"	3'-6"	2'-11"
2-550S162-68	6'-10"	6'-5"	5'-11"	5'-8"	5'-4"	5'-11"	5'-6"	4'-11"	4'-7"	4'-3"
2-550S162-97	8'-5"	7'-7"	4'-4"	6'-10"	6'-7"	7'-3"	6'-8"	6'-4"	5'-11"	5'-8"
2-800S162-33	3'-8"	—	—	—	—	—	—	—	—	—
2-800S162-43	6'-1"	5'-5"	4'-9"	4'-2"	3'-8"	4'-7"	3'-9"	—	—	—
2-800S162-54	8'-0"	7'-4"	6'-8"	6'-1"	5'-7"	6'-6"	5'-8"	5'-3"	4'-8"	4'-3"
2-800S162-68	9'-1"	8'-6"	7'-11"	7'-7"	7'-1"	7'-10"	7'-5"	6'-9"	6'-3"	5'-9"
2-800S162-97	11'-1"	10'-4"	9'-8"	9'-2"	8'-9"	9'-8"	8'-11"	8'-5"	7'-11"	7'-7"
2-1000S162-43	6'-9"	6'-0"	5'-5"	4'-9"	4'-2"	5'-2"	4'-5"	—	—	—
2-1000S162-54	8'-11"	8'-2"	7'-6"	6'-10"	6'-6"	7'-4"	6'-7"	5'-10"	5'-4"	4'-9"
2-1000S162-68	10'-9"	10'-1"	9'-6"	8'-11"	8'-6"	9'-5"	8'-9"	8'-1"	7'-6"	6'-10"
2-1000S162-97	13'-1"	12'-4"	11'-6"	10'-10"	10'-5"	11'-5"	10'-7"	9'-11"	9'-6"	8'-11"
2-1200S162-43	7'-6"	6'-7"	5'-10"	5'-2"	4'-7"	5'-8"	4'-10"	—	—	—
2-1200S162-54	9'-9"	8'-10"	8'-1"	7'-6"	6'-10"	7'-11"	7'-2"	6'-6"	5'-9"	5'-3"
2-1200S162-68	11'-7"	10'-9"	10'-2"	9'-7"	9'-1"	10'-2"	9'-6"	8'-7"	7'-11"	7'-5"
2-1200S162-97	15'-1"	14'-1"	13'-4"	12'-7"	12'-0"	13'-2"	12'-4"	11'-7"	10'-11"	10'-6"

For SI: 1 inch = 25.4 mm, 1 foot = 304.8 mm, 1 pound per square foot = 0.0479kPa, 1 pound per square inch = 6.895 kPa.

a. Deflection criteria: $L/360$ for live loads, $L/240$ for total loads.

b. Design load assumptions:

Roof/Ceiling dead load is 12 psf.

Attic dead load is 10 psf.

c. Building width is in the direction of horizontal framing members supported by the header.

TABLE R603.6(7)
BACK-TO-BACK HEADER SPANS
Headers supporting one floor, roof and ceiling (33 ksi steel)^{a, b, c}

MEMBER DESIGNATION	GROUND SNOW LOAD (20 psf)					GROUND SNOW LOAD (30 psf)				
	Building width ^c					Building width ^c				
	24'	28'	32'	36'	40'	24'	28'	32'	36'	40'
2-350S162-33	—	—	—	—	—	—	—	—	—	—
2-350S162-43	2'-7"	2'-1"	—	—	—	2'-6"	—	—	—	—
2-350S162-54	3'-8"	3'-3"	2'-9"	2'-6"	2'-1"	3'-7"	3'-1"	2'-8"	2'-5"	1'-11"
2-350S162-68	4'-5"	4'-0"	3'-9"	3'-6"	3'-1"	4'-4"	3'-11"	3'-8"	3'-5"	3'-0"
2-350S162-97	5'-5"	4'-11"	4'-8"	4'-5"	4'-1"	5'-4"	4'-10"	4'-7"	4'-4"	4'-0"
2-550S162-33	—	—	—	—	—	—	—	—	—	—
2-550S162-43	4'-1"	3'-6"	2'-10"	2'-5"	—	3'-11"	3'-5"	2'-9"	—	—
2-550S162-54	5'-5"	4'-9"	4'-4"	3'-10"	3'-6"	5'-3"	4'-8"	4'-3"	3'-9"	3'-5"
2-550S162-68	6'-6"	5'-10"	5'-6"	5'-1"	4'-8"	6'-2"	5'-9"	5'-5"	4'-11"	4'-7"
2-550S162-97	7'-8"	7'-2"	6'-8"	6'-5"	5'-11"	7'-7"	7'-0"	6'-7"	6'-3"	5'-10"
2-800S162-33	—	—	—	—	—	—	—	—	—	—
2-800S162-43	5'-4"	4'-7"	3'-10"	3'-4"	—	5'-1"	4'-5"	3'-9"	—	—
2-800S162-54	7'-3"	6'-6"	5'-10"	5'-4"	4'-9"	6'-11"	6'-4"	5'-8"	5'-3"	4'-8"
2-800S162-68	8'-5"	7'-9"	7'-5"	6'-9"	6'-5"	8'-4"	7'-8"	7'-3"	6'-8"	6'-3"
2-800S162-97	10'-2"	9'-6"	8'-11"	8'-6"	8'-1"	10'-0"	9'-5"	8'-9"	8'-5"	7'-10"
2-1000S162-43	5'-9"	5'-1"	4'-5"	3'-9"	—"	5'-8"	4'-11"	4'-4"	—	—
2-1000S162-54	7'-11"	7'-3"	6'-7"	5'-11"	5'-5"	7'-9"	7'-1"	6'-5"	5'-9"	5'-4"
2-1000S162-68	9'-11"	9'-4"	8'-9"	8'-1"	7'-7"	9'-10"	9'-2"	8'-7"	7'-11"	7'-5"
2-1000S162-97	12'-1"	11'-4"	10'-8"	10'-0"	9'-7"	11'-11"	11'-1"	10'-6"	9'-10"	9'-6"
2-1200S162-43	6'-6"	5'-8"	4'-10"	4'-2"	—	6'-4"	5'-6"	4'-8"	—	—
2-1200S162-54	8'-8"	7'-10"	7'-2"	6'-6"	5'-11"	8'-6"	7'-8"	6'-11"	6'-5"	5'-9"
2-1200S162-68	10'-8"	9'-11"	9'-5"	8'-8"	8'-1"	10'-6"	9'-9"	9'-3"	8'-6"	7'-11"
2-1200S162-97	13'-11"	13'-0"	12'-4"	11'-7"	11'-1"	13'-9"	12'-10"	12'-1"	11'-6"	10'-10"

For SI: 1 inch = 25.4 mm, 1 foot = 304.8 mm, 1 pound per square foot = 0.0479 kPa, 1 pound per square inch = 6.895 kPa.

a. Deflection criteria: *L*/360 for live loads, *L*/240 for total loads.

b. Design load assumptions:

Second floor dead load is 10 psf.

Roof/Ceiling dead load is 12 psf.

Second floor live load is 30 psf.

Roof/ceiling load is 12 psf.

Attic dead load is 10 psf.

c. Building width is in the direction of horizontal framing members supported by the header.

TABLE R603.6(8)
BACK-TO-BACK HEADER SPANS
Headers supporting one floor, roof and ceiling (33 ksi steel)^{a, b, c}

MEMBER DESIGNATION	GROUND SNOW LOAD (50 psf)					GROUND SNOW LOAD (70 psf)				
	Building width ^c					Building width ^c				
	24'	28'	32'	36'	40'	24'	28'	32'	36'	40'
2-350S162-33	—	—	—	—	—	—	—	—	—	—
2-350S162-43	—	—	—	—	—	—	—	—	—	—
2-350S162-54	2'-11"	2'-6"	2'-2"	—	—	2'-4"	—	—	—	—
2-350S162-68	3'-10"	3'-6"	3'-2"	2'-9"	2'-6"	3'-4"	2'-10"	2'-6"	2'-3"	1'-10"
2-350S162-97	4'-9"	4'-5"	4'-2"	3'-10"	3'-8"	4'-3"	3'-10"	3'-8"	3'-5"	3'-2"
2-550S162-33	—	—	—	—	—	—	—	—	—	—
2-550S162-43	3'-1"	2'-5"	—	—	—	—	—	—	—	—
2-550S162-54	4'-6"	3'-10"	3'-6"	3'-0"	2'-7"	3'-8"	3'-1"	2'-7"	2'-1"	—
2-550S162-68	5'-7"	5'-1"	4'-8"	4'-4"	3'-11"	4'-10"	4'-5"	3'-10"	3'-6"	3'-3"
2-550S162-97	6'-10"	6'-5"	5'-11"	5'-8"	5'-5"	6'-2"	5'-8"	5'-5"	3'-1"	4'-9"
2-800S162-33	—	—	—	—	—	—	—	—	—	—
2-800S162-43	4'-1"	3'-5"	—	—	—	—	—	—	—	—
2-800S162-54	6'-0"	5'-5"	4'-9"	4'-4"	3'-9"	4'-11"	4'-5"	3'-9"	3'-2"	—
2-800S162-68	7'-6"	6'-10"	6'-5"	5'-10"	5'-5"	6'-7"	5'-10"	5'-5"	4'-10"	4'-6"
2-800S162-97	9'-1"	8'-6"	8'-0"	7'-7"	7'-4"	8'-3"	7'-8"	7'-3"	6'-9"	6'-6"
2-1000S162-43	4'-8"	3'-10"	—	—	—	—	—	—	—	—
2-1000S162-54	6'-9"	6'-0"	5'-5"	4'-10"	4'-4"	5'-8"	4'-10"	4'-4"	3'-8"	—
2-1000S162-68	8'-10"	8'-3"	7'-7"	6'-11"	6'-6"	7'-9"	7'-1"	6'-6"	5'-10"	5'-5"
2-1000S162-97	10'-10"	10'-3"	9'-7"	9'-1"	8'-8"	9'-9"	9'-3"	8'-7"	8'-3"	7'-9"
2-1200S162-43	5'-1"	4'-4"	—	—	—	—	—	—	—	—
2-1200S162-54	7'-5"	6'-6"	5'-10"	5'-4"	4'-9"	6'-3"	5'-5"	4'-8"	4'-1"	—
2-1200S162-68	9'-7"	8'-9"	8'-1"	7'-6"	6'-11"	8'-8"	7'-7"	6'-11"	6'-4"	5'-9"
2-1200S162-97	12'-6"	11'-8"	11'-1"	10'-6"	9'-11"	11'-4"	10'-7"	10'-0"	9'-6"	9'-0"

For SI: 1 inch = 25.4 mm, 1 foot = 304.8 mm, 1 pound per square foot = 0.0479kPa, 1 pound per square inch = 6.895 kPa.

a. Deflection criteria: $L/360$ for live loads, $L/240$ for total loads.

b. Design load assumptions:

Second floor dead load is 10 psf.

Roof/Ceiling dead load is 12 psf.

Second floor live load is 30 psf.

Roof/ceiling dead load is 12 psf.

Attic dead load is 10 psf.

c. Building width is in the direction of horizontal framing members supported by the header.

TABLE R603.6(9)
TOTAL NUMBER OF JACK AND KING STUDS REQUIRED AT EACH END OF AN OPENING

SIZE OF OPENING (feet-inches)	24" O.C. STUD SPACING		16" O.C. STUD SPACING	
	No. of jack studs	No. of king studs	No. of jack studs	No. of king studs
Up to 3'-6"	1	1	1	1
> 3'-6" to 5'-0"	1	2	1	2
> 5'-0" to 5'-6"	1	2	2	2
> 5'-6" to 8'-0"	1	2	2	2
> 8'-0" to 10'-6"	2	2	2	3
> 10'-6" to 12'-0"	2	2	3	3
> 12'-0" to 13'-0"	2	3	3	3
> 13'-0" to 14'-0"	2	3	3	4
> 14'-0" to 16'-0"	2	3	3	4
> 16'-0" to 18'-0"	3	3	4	4

For SI: 1 inch = 25.4 mm, 1 foot = 304.8 mm.

TABLE R603.6(10)
HEADER TO KING STUD CONNECTION REQUIREMENTS^{a, b, c, d}

HEADER SPAN (feet)	BASIC WIND SPEED (mph), EXPOSURE		
	85 A/B or Seismic Design Categories A, B, C, D ₀ , D ₁ and D ₂	85 C or less than 110 A/B	Less than 110 C
≤ 4'	4-No. 8 screws	4-No. 8 screws	6-No. 8 screws
> 4' to 8'	4-No. 8 screws	4-No. 8 screws	8-No. 8 screws
> 8' to 12'	4-No. 8 screws	6-No. 8 screws	10-No. 8 screws
> 12' to 16'	4-No. 8 screws	8-No. 8 screws	12-No. 8 screws

For SI: 1 inch = 25.4 mm, 1 foot = 304.8 mm, 1 mile per hour = 0.447 m/s, 1 pound = 4.448 N.

- a. All screw sizes shown are minimum.
- b. For headers located on the first floor of a two-story building, the total number of screws may be reduced by two screws, but the total number of screws shall be no less than four.
- c. For roof slopes of 6:12 or greater, the required number of screws may be reduced by half, but the total number of screws shall be no less than four.
- d. Screws can be replaced by an uplift connector which has a capacity of the number of screws multiplied by 164 pounds (e.g., 12-No. 8 screws can be replaced by an uplift connector whose capacity exceeds 12 × 164 pounds = 1,968 pounds).

TABLE R603.6(11)
HEAD TRACK SPAN (33 ksi Steel)

BASIC WIND SPEED (mph)		ALLOWABLE HEAD TRACK SPAN ^{a, b} (ft-in)					
Exposure		Track Designation					
A/B	C	350T125-33	350T125-43	350T125-54	550T125-33	550T125-43	550T125-54
85		5'-0"	5'-7"	6'-2"	5'-10"	6'-8"	7'-0"
90		4'-10"	5'-5"	6'-0"	5'-8"	6'-3"	6'-10"
100	85	4'-6"	5'-1"	5'-8"	5'-4"	5'-11"	6'-5"
110	90	4'-2"	4'-9"	5'-4"	5'-1"	5'-7"	6'-1"
	100	3'-11"	4'-6"	5'-0"	4'-10"	5'-4"	5'-10"
	110	3'-8"	4'-2"	4'-9"	4'-1"	5'-1"	5'-7"

For SI: 1 inch = 25.4 mm, 1 foot = 304.8 mm, 1 mile per hour = 0.447 m/s.

- a. Deflection Limit: L/240
- b. Head track spans are based on components and cladding wind speeds and a 49-inch tributary span.

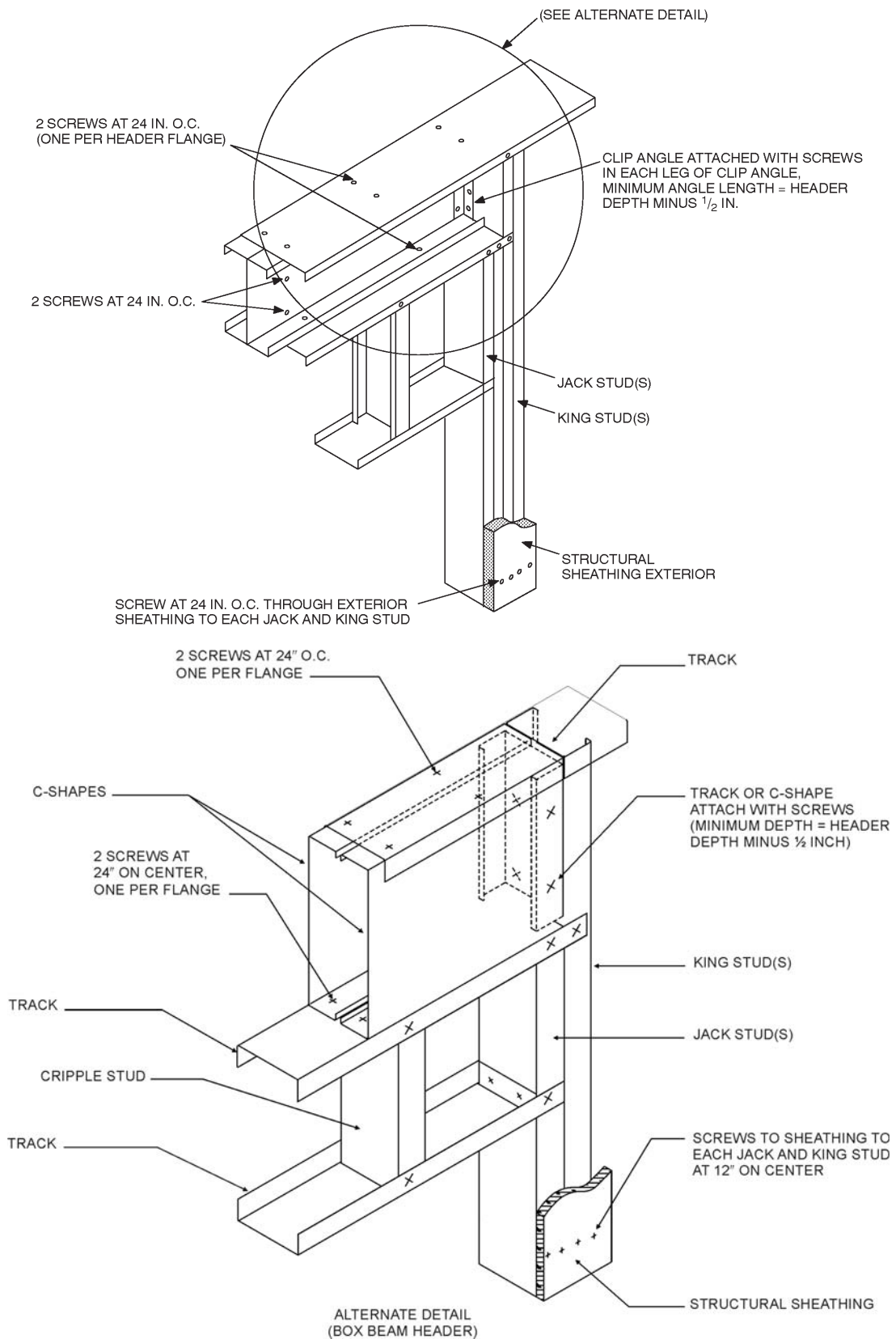

For SI: 1 inch = 25.4 mm.

**FIGURE R603.6
HEADER DETAIL**

TABLE R603.7
MINIMUM PERCENTAGE OF FULL HEIGHT STRUCTURAL SHEATHING ON EXTERIOR WALLS^{a, b, c, d, e}

WALL SUPPORTING	ROOF SLOPE	WIND SPEED (mph) AND EXPOSURE				
		85 A/B	100 A/B	110 A/B or 85 C	100 C	110 C
Roof and ceiling only	3:12	8	9	12	16	20
	6:12	12	15	20	26	35
	9:12	21	25	30	50	58
	12:12	30	35	40	66	75
One story, roof and ceiling	3:12	24	30	35	50	66
	6:12	25	30	40	58	74
	9:12	35	40	55	74	91
	12:12	40	50	65	100	115

For SI: 1 mile per hour = 0.447 m/s.

- Linear interpolation shall be permitted.
- Bracing amount shall not be less than 20 percent of the wall length after all applicable adjustments are made.
- Minimum percentages are based on a building aspect ratio of 1:1. Minimum percentages for the shorter walls of a building shall be multiplied by a factor of 1.5 and 2.0 for building aspect ratios of 1.5:1 and 2:1 respectively.
- For hip roofed homes with continuous structural sheathing, the amount of bracing shall be permitted to be multiplied by a factor of 0.95 for roof slopes not exceeding 7:12 and a factor of 0.9 for roof slopes greater than 7:12.
- Sheathing percentages are permitted to be reduced in accordance with Section R603.7.2.

SECTION R604 WOOD STRUCTURAL PANELS

R604.1 Identification and grade. Wood structural panels shall conform to DOC PS 1 or DOC PS 2. All panels shall be identified by a grade mark or certificate of inspection issued by an approved agency.

R604.2 Allowable spans. The maximum allowable spans for wood structural panel wall sheathing shall not exceed the values set forth in Table R602.3(3).

R604.3 Installation. Wood structural panel wall sheathing shall be attached to framing in accordance with Table R602.3(1). Wood structural panels marked Exposure 1 or Exterior are considered water-repellent sheathing under the code.

SECTION R605 PARTICLEBOARD

R605.1 Identification and grade. Particleboard shall conform to ANSI A208.1 and shall be so identified by a grade mark or certificate of inspection issued by an approved agency. Particleboard shall comply with the grades specified in Table R602.3(4).

SECTION R606 GENERAL MASONRY CONSTRUCTION

R606.1 General. Masonry construction shall be designed and constructed in accordance with the provisions of this section or in accordance with the provisions of ACI 530/ASCE 5/TMS 402.

R606.1.1 Professional registration not required. When the empirical design provisions of ACI 530/ASCE 5/TMS 402 Chapter 5 or the provisions of this section are used to design masonry, project drawings, typical details and specifications are not required to bear the seal of the architect or

engineer responsible for design, unless otherwise required by the state law of the jurisdiction having authority.

R606.2 Thickness of masonry. The nominal thickness of masonry walls shall conform to the requirements of Sections R606.2.1 through R606.2.4.

R606.2.1 Minimum thickness. The minimum thickness of masonry bearing walls more than one story high shall be 8 inches (203 mm). Solid masonry walls of one-story dwellings and garages shall not be less than 6 inches (152 mm) in thickness when not greater than 9 feet (2743 mm) in height, provided that when gable construction is used, an additional 6 feet (1829 mm) is permitted to the peak of the gable. Masonry walls shall be laterally supported in either the horizontal or vertical direction at intervals as required by Section R606.9.

R606.2.2 Rubble stone masonry wall. The minimum thickness of rough, random or coursed rubble stone masonry walls shall be 16 inches (406 mm).

R606.2.3 Change in thickness. Where walls of masonry of hollow units or masonry-bonded hollow walls are decreased in thickness, a course of solid masonry shall be constructed between the wall below and the thinner wall above, or special units or construction shall be used to transmit the loads from face shells or wythes above to those below.

R606.2.4 Parapet walls. Unreinforced solid masonry parapet walls shall not be less than 8 inches (203 mm) thick and their height shall not exceed four times their thickness. Unreinforced hollow unit masonry parapet walls shall be not less than 8 inches (203 mm) thick, and their height shall not exceed three times their thickness. Masonry parapet walls in areas subject to wind loads of 30 pounds per square foot (1.44 kPa) located in Seismic Design Category D₀, D₁ or D₂, or on townhouses in Seismic Design Category C shall be reinforced in accordance with Section R606.12.

R606.3 Corbeled masonry. Solid masonry units shall be used for corbeling. The maximum corbeled projection beyond the

face of the wall shall not be more than one-half of the wall thickness or one-half the wythe thickness for hollow walls; the maximum projection of one unit shall not exceed one-half the height of the unit or one-third the thickness at right angles to the wall. When corbeled masonry is used to support floor or roof-framing members, the top course of the corbel shall be a header course or the top course bed joint shall have ties to the vertical wall. The hollow space behind the corbeled masonry shall be filled with mortar or grout.

R606.4 Support conditions. Bearing and support conditions shall be in accordance with Sections R606.4.1 and R606.4.2.

R606.4.1 Bearing on support. Each masonry wythe shall be supported by at least two-thirds of the wythe thickness.

R606.4.2 Support at foundation. Cavity wall or masonry veneer construction may be supported on an 8-inch (203 mm) foundation wall, provided the 8-inch (203 mm) wall is corbeled with solid masonry to the width of the wall system above. The total horizontal projection of the corbel shall not exceed 2 inches (51 mm) with individual corbels projecting not more than one-third the thickness of the unit or one-half the height of the unit.

R606.5 Allowable stresses. Allowable compressive stresses in masonry shall not exceed the values prescribed in Table R606.5. In determining the stresses in masonry, the effects of all loads and conditions of loading and the influence of all forces affecting the design and strength of the several parts shall be taken into account.

R606.5.1 Combined units. In walls or other structural members composed of different kinds or grades of units, materials or mortars, the maximum stress shall not exceed the allowable stress for the weakest of the combination of units, materials and mortars of which the member is composed. The net thickness of any facing unit that is used to resist stress shall not be less than 1.5 inches (38 mm).

R606.6 Piers. The unsupported height of masonry piers shall not exceed ten times their least dimension. When structural clay tile or hollow concrete masonry units are used for isolated piers to support beams and girders, the cellular spaces shall be filled solidly with concrete or Type M or S mortar, except that unfilled hollow piers may be used if their unsupported height is not more than four times their least dimension. Where hollow masonry units are solidly filled with concrete or Type M, S or N mortar, the allowable compressive stress shall be permitted to be increased as provided in Table R606.5.

R606.6.1 Pier cap. Hollow piers shall be capped with 4 inches (102 mm) of solid masonry or concrete or shall have cavities of the top course filled with concrete or grout or other approved methods.

R606.7 Chases. Chases and recesses in masonry walls shall not be deeper than one-third the wall thickness, and the maximum length of a horizontal chase or horizontal projection shall not exceed 4 feet (1219 mm), and shall have at least 8 inches (203 mm) of masonry in back of the chases and recesses and between adjacent chases or recesses and the jambs of openings. Chases and recesses in masonry walls shall be designed and constructed so as not to reduce the required strength or required fire resistance of the wall and in no case shall a chase or recess

be permitted within the required area of a pier. Masonry directly above chases or recesses wider than 12 inches (305 mm) shall be supported on noncombustible lintels.

**TABLE R606.5
ALLOWABLE COMPRESSIVE STRESSES FOR
EMPIRICAL DESIGN OF MASONRY**

CONSTRUCTION; COMPRESSIVE STRENGTH OF UNIT, GROSS AREA	ALLOWABLE COMPRESSIVE STRESSES ^a GROSS CROSS-SECTIONAL AREA ^b	
	Type M or S mortar	Type N mortar
Solid masonry of brick and other solid units of clay or shale; sand-lime or concrete brick:		
8,000 + psi	350	300
4,500 psi	225	200
2,500 psi	160	140
1,500 psi	115	100
Grouted ^c masonry, of clay or shale; sand-lime or concrete:		
4,500+ psi	225	200
2,500 psi	160	140
1,500 psi	115	100
Solid masonry of solid concrete masonry units:		
3,000+ psi	225	200
2,000 psi	160	140
1,200 psi	115	100
Masonry of hollow load-bearing units:		
2,000+ psi	140	120
1,500 psi	115	100
1,000 psi	75	70
700 psi	60	55
Hollow walls (cavity or masonry bonded ^d) solid units:		
2,500+ psi	160	140
1,500 psi	115	100
Hollow units	75	70
Stone ashlar masonry:		
Granite	720	640
Limestone or marble	450	400
Sandstone or cast stone	360	320
Rubble stone masonry:		
Coarse, rough or random	120	100

For SI: 1 pound per square inch = 6.895 kPa.

- a. Linear interpolation shall be used for determining allowable stresses for masonry units having compressive strengths that are intermediate between those given in the table.
- b. Gross cross-sectional area shall be calculated on the actual rather than nominal dimensions.
- c. See Section R608.
- d. Where floor and roof loads are carried upon one wythe, the gross cross-sectional area is that of the wythe under load; if both wythes are loaded, the gross cross-sectional area is that of the wall minus the area of the cavity between the wythes. Walls bonded with metal ties shall be considered as cavity walls unless the collar joints are filled with mortar or grout.

R606.8 Stack bond. In unreinforced masonry where masonry units are laid in stack bond, longitudinal reinforcement consisting of not less than two continuous wires each with a minimum

aggregate cross-sectional area of 0.017 square inch (11 mm²) shall be provided in horizontal bed joints spaced not more than 16 inches (406 mm) on center vertically.

R606.9 Lateral support. Masonry walls shall be laterally supported in either the horizontal or the vertical direction. The maximum spacing between lateral supports shall not exceed the distances in Table R606.9. Lateral support shall be provided by cross walls, pilasters, buttresses or structural frame members when the limiting distance is taken horizontally, or by floors or roofs when the limiting distance is taken vertically.

**TABLE R606.9
SPACING OF LATERAL SUPPORT FOR MASONRY WALLS**

CONSTRUCTION	MAXIMUM WALL LENGTH TO THICKNESS OR WALL HEIGHT TO THICKNESS ^{a,b}
Bearing walls:	
Solid or solid grouted	20
All other	18
Nonbearing walls:	
Exterior	18
Interior	36

For SI: 1 foot = 304.8 mm.

- a. Except for cavity walls and cantilevered walls, the thickness of a wall shall be its nominal thickness measured perpendicular to the face of the wall. For cavity walls, the thickness shall be determined as the sum of the nominal thicknesses of the individual wythes. For cantilever walls, except for parapets, the ratio of height to nominal thickness shall not exceed 6 for solid masonry, or 4 for hollow masonry. For parapets, see Section R606.2.4.
- b. An additional unsupported height of 6 feet is permitted for gable end walls.

R606.9.1 Horizontal lateral support. Lateral support in the horizontal direction provided by intersecting masonry walls shall be provided by one of the methods in Section R606.9.1.1 or Section R606.9.1.2.

R606.9.1.1 Bonding pattern. Fifty percent of the units at the intersection shall be laid in an overlapping masonry bonding pattern, with alternate units having a bearing of not less than 3 inches (76 mm) on the unit below.

R606.9.1.2 Metal reinforcement. Interior nonload-bearing walls shall be anchored at their intersections, at vertical intervals of not more than 16 inches (406 mm) with joint reinforcement of at least 9 gage [0.148 in. (4mm)], or 1/4 inch (6 mm) galvanized mesh hardware cloth. Intersecting masonry walls, other than interior nonloadbearing walls, shall be anchored at vertical intervals of not more than 8 inches (203 mm) with joint reinforcement of at least 9 gage and shall extend at least 30 inches (762 mm) in each direction at the intersection. Other metal ties, joint reinforcement or anchors, if used, shall be spaced to provide equivalent area of anchorage to that required by this section.

R606.9.2 Vertical lateral support. Vertical lateral support of masonry walls in Seismic Design Category A, B or C shall be provided in accordance with one of the methods in Section R606.9.2.1 or Section R606.9.2.2.

R606.9.2.1 Roof structures. Masonry walls shall be anchored to roof structures with metal strap anchors spaced in accordance with the manufacturer's instructions, 1/2-inch (13 mm) bolts spaced not more than 6 feet (1829 mm) on center, or other approved anchors. Anchors shall be embedded at least 16 inches (406 mm)

into the masonry, or be hooked or welded to bond beam reinforcement placed not less than 6 inches (152 mm) from the top of the wall.

R606.9.2.2 Floor diaphragms. Masonry walls shall be anchored to floor diaphragm framing by metal strap anchors spaced in accordance with the manufacturer's instructions, 1/2-inch-diameter (13 mm) bolts spaced at intervals not to exceed 6 feet (1829 mm) and installed as shown in Figure R606.11(1), or by other approved methods.

R606.10 Lintels. Masonry over openings shall be supported by steel lintels, reinforced concrete or masonry lintels or masonry arches, designed to support load imposed.

R606.11 Anchorage. Masonry walls shall be anchored to floor and roof systems in accordance with the details shown in Figure R606.11(1), R606.11(2) or R606.11(3). Footings may be considered as points of lateral support.

R606.12 Seismic requirements. The seismic requirements of this section shall apply to the design of masonry and the construction of masonry building elements located in Seismic Design Category D₀, D₁ or D₂. Townhouses in Seismic Design Category C shall comply with the requirements of Section R606.12.2. These requirements shall not apply to glass unit masonry conforming to Section R610 or masonry veneer conforming to Section R703.7.

R606.12.1 General. Masonry structures and masonry elements shall comply with the requirements of Sections R606.12.2 through R606.12.4 based on the seismic design category established in Table R301.2(1). Masonry structures and masonry elements shall comply with the requirements of Section R606.12 and Figures R606.11(1), R606.11(2) and R606.11(3) or shall be designed in accordance with ACI 530/ASCE 5/TMS 402.

R606.12.1.1 Floor and roof diaphragm construction. Floor and roof diaphragms shall be constructed of wood structural panels attached to wood framing in accordance with Table R602.3(1) or to cold-formed steel floor framing in accordance with Table R505.3.1(2) or to cold-formed steel roof framing in accordance with Table R804.3. Additionally, sheathing panel edges perpendicular to framing members shall be backed by blocking, and sheathing shall be connected to the blocking with fasteners at the edge spacing. For Seismic Design Categories C, D₀, D₁ and D₂, where the width-to-thickness dimension of the diaphragm exceeds 2-to-1, edge spacing of fasteners shall be 4 inches (102 mm) on center.

R606.12.2 Seismic Design Category C. Townhouses located in Seismic Design Category C shall comply with the requirements of this section.

R606.12.2.1 Design of elements not part of the lateral force-resisting system.

R606.12.2.1.1 Load-bearing frames or columns. Elements not part of the lateral-force-resisting system shall be analyzed to determine their effect on the response of the system. The frames or columns shall be adequate for vertical load carrying capacity and induced moment caused by the design story drift.

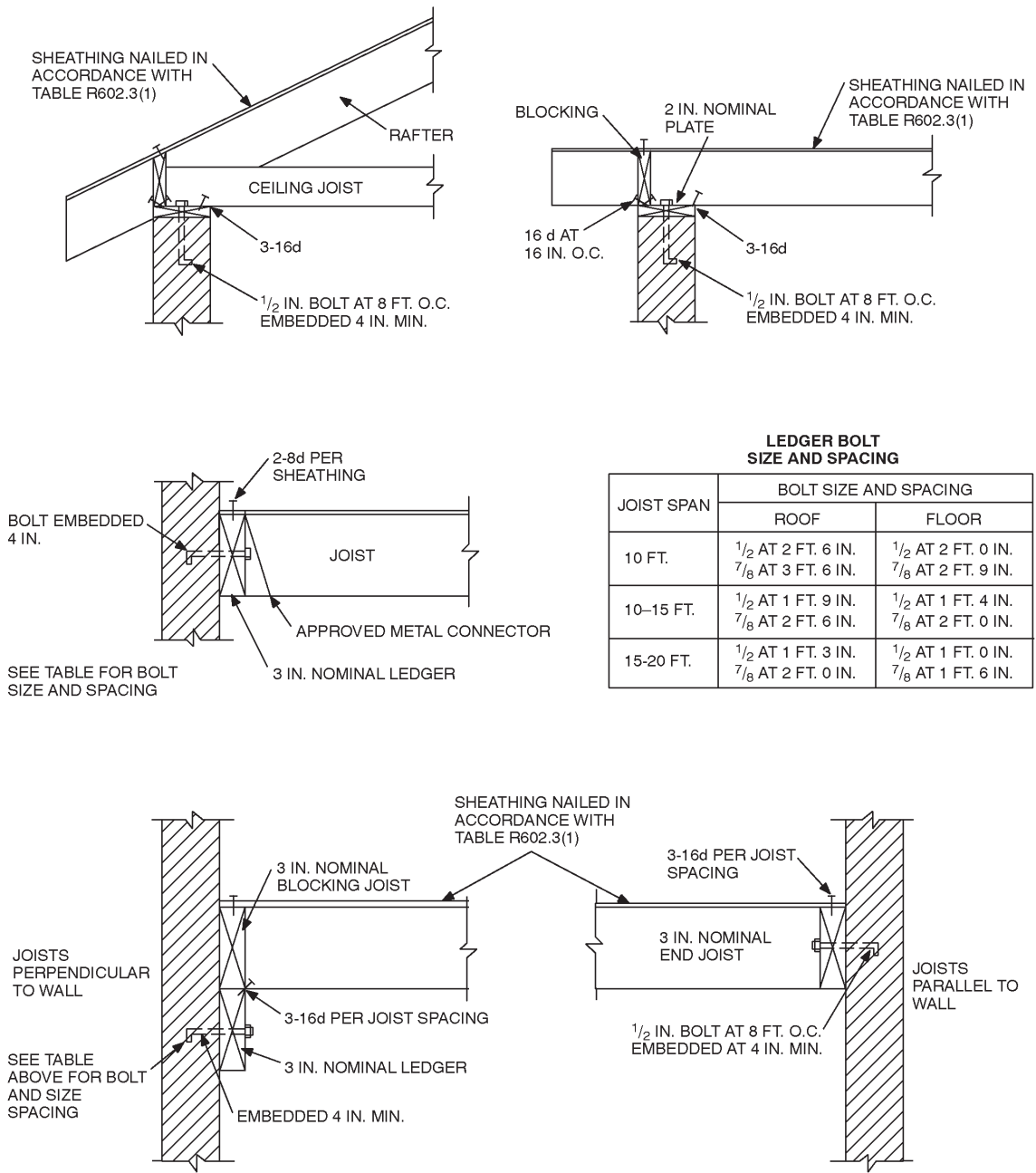

NOTE: Where bolts are located in hollow masonry, the cells in the courses receiving the bolt shall be grouted solid.
 For SI: 1 inch = 25.4 mm, 1 foot = 304.8 mm, 1 pound per square foot = 0.0479 kPa.

FIGURE R606.11(1)
ANCHORAGE REQUIREMENTS FOR MASONRY WALLS LOCATED IN SEISMIC DESIGN CATEGORY A, B OR C AND WHERE WIND LOADS ARE LESS THAN 30 PSF

WALL CONSTRUCTION

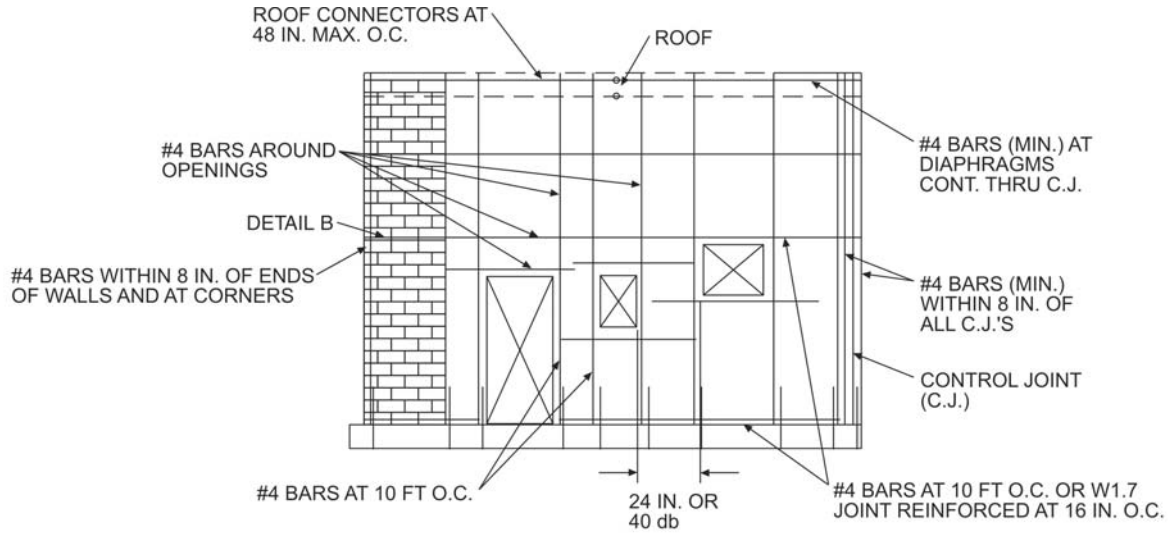

MINIMUM REINFORCEMENT FOR MASONRY WALLS

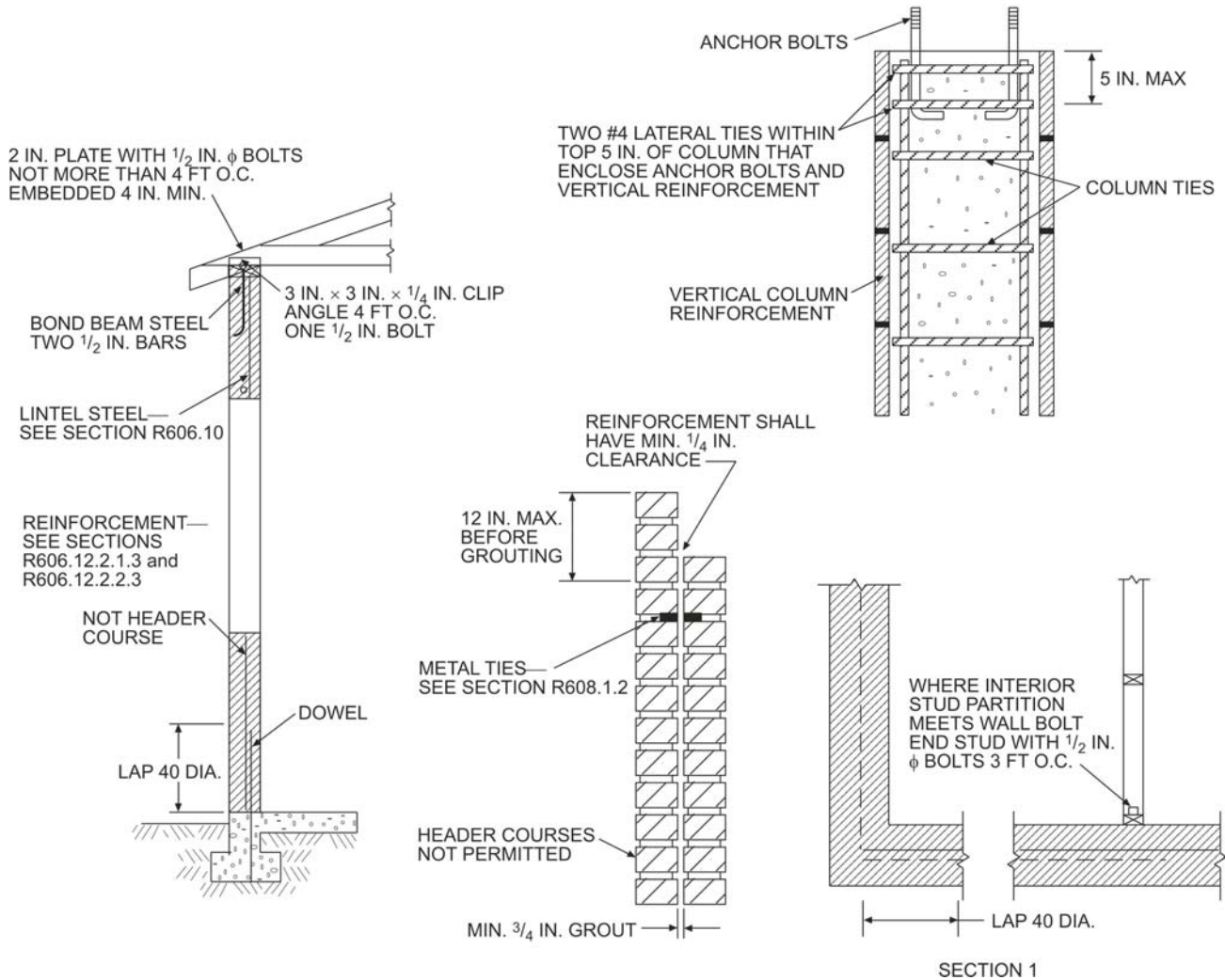

SECTION 1

For SI: 1 inch = 25.4 mm, 1 foot = 304.8 mm.

**FIGURE R606.11(2)
REQUIREMENTS FOR REINFORCED GROUDED MASONRY CONSTRUCTION IN SEISMIC DESIGN CATEGORY C**

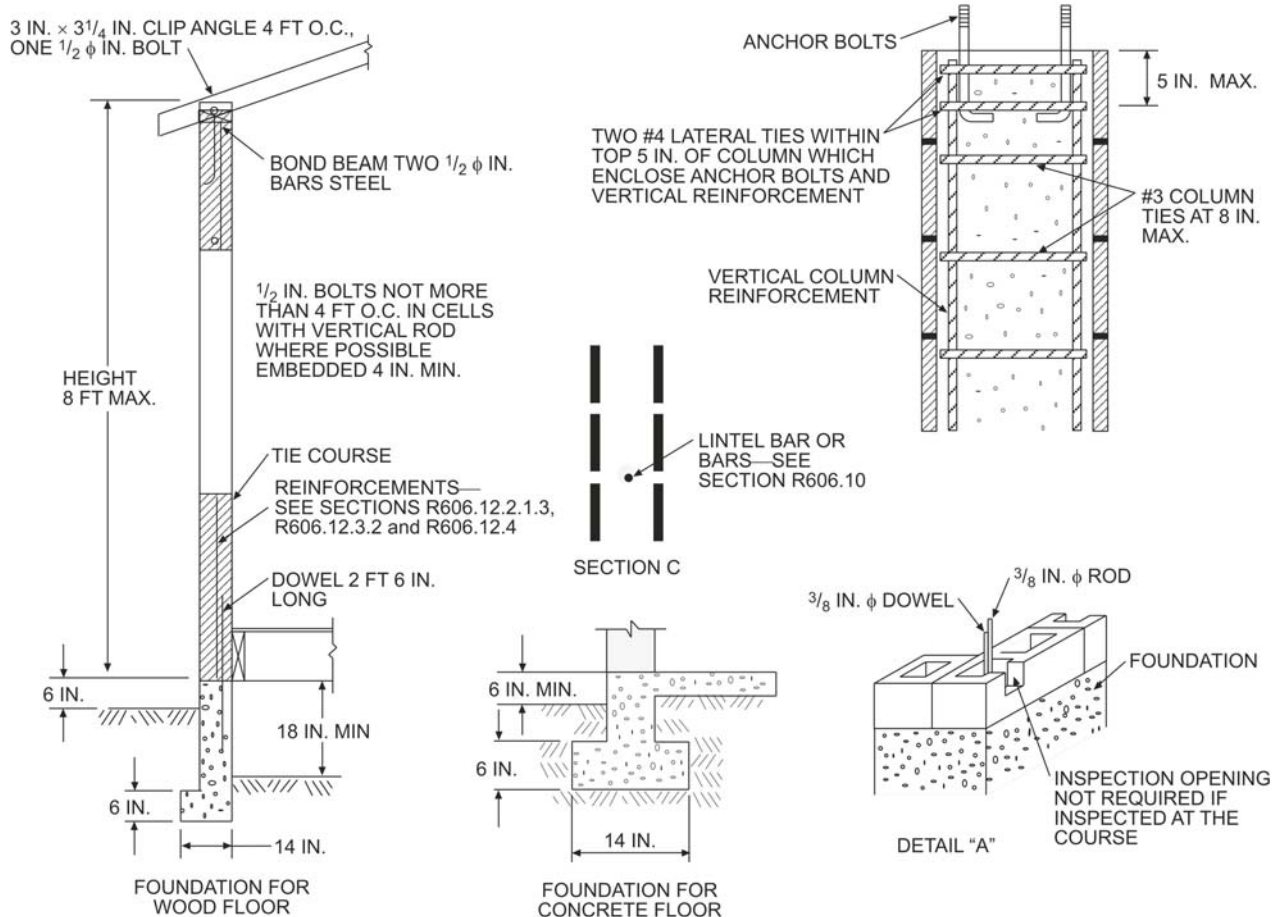
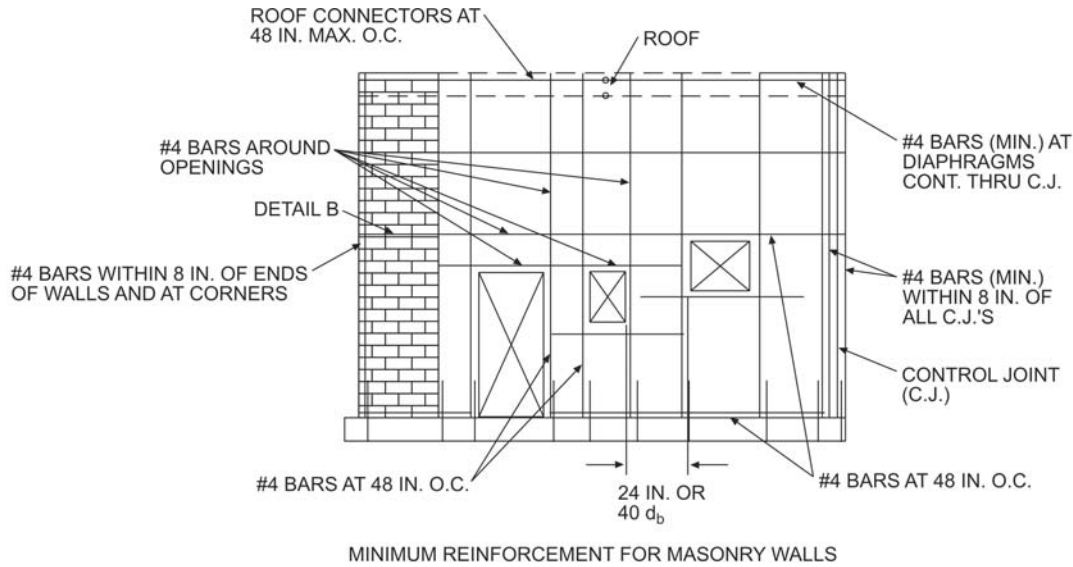

Note: A full bed joint must be provided. All cells containing vertical bars are to be filled to the top of wall and provide inspection opening as shown on detail "A." Horizontal bars are to be laid as shown on detail "B." Lintel bars are to be laid as shown on Section C.

NOTE: A full bed joint must be provided. All cells containing vertical bars are to be filled to the top of wall and provide inspection opening as shown on detail "A." Horizontal bars are to be laid as shown on detail "B." Lintel bars are to be laid as shown on Section C.

For SI: 1 inch = 25.4 mm, 1 foot = 304.8 mm.

FIGURE R606.11(3)
REQUIREMENTS FOR REINFORCED MASONRY CONSTRUCTION IN SEISMIC DESIGN CATEGORY D₀, D₁ OR D₂

R606.12.2.1.2 Masonry partition walls. Masonry partition walls, masonry screen walls and other masonry elements that are not designed to resist vertical or lateral loads, other than those induced by their own weight, shall be isolated from the structure so that vertical and lateral forces are not imparted to these elements. Isolation joints and connectors between these elements and the structure shall be designed to accommodate the design story drift.

R606.12.2.1.3 Reinforcement requirements for masonry elements. Masonry elements listed in Section R606.12.2.1.2 shall be reinforced in either the horizontal or vertical direction as shown in Figure R606.11(2) and in accordance with the following:

1. Horizontal reinforcement. Horizontal joint reinforcement shall consist of at least two longitudinal W1.7 wires spaced not more than 16 inches (406 mm) for walls greater than 4 inches (102 mm) in width and at least one longitudinal W1.7 wire spaced not more than 16 inches (406 mm) for walls not exceeding 4 inches (102 mm) in width; or at least one No. 4 bar spaced not more than 48 inches (1219 mm). Where two longitudinal wires of joint reinforcement are used, the space between these wires shall be the widest that the mortar joint will accommodate. Horizontal reinforcement shall be provided within 16 inches (406 mm) of the top and bottom of these masonry elements.
2. Vertical reinforcement. Vertical reinforcement shall consist of at least one No. 4 bar spaced not more than 48 inches (1219 mm). Vertical reinforcement shall be located within 16 inches (406 mm) of the ends of masonry walls.

R606.12.2.2 Design of elements part of the lateral-force-resisting system.

R606.12.2.2.1 Connections to masonry shear walls. Connectors shall be provided to transfer forces between masonry walls and horizontal elements in accordance with the requirements of Section 2.1.8 of ACI 530/ASCE 5/TMS 402. Connectors shall be designed to transfer horizontal design forces acting either perpendicular or parallel to the wall, but not less than 200 pounds per linear foot (2919 N/m) of wall. The maximum spacing between connectors shall be 4 feet (1219 mm). Such anchorage mechanisms shall not induce tension stresses perpendicular to grain in ledgers or nailers.

R606.12.2.2.2 Connections to masonry columns. Connectors shall be provided to transfer forces between masonry columns and horizontal elements in accordance with the requirements of Section 2.1.8 of ACI 530/ASCE 5/TMS 402. Where anchor bolts are used to connect horizontal elements to the tops of columns, the bolts shall be placed within lateral ties. Lateral ties shall enclose both the vertical bars in the column and the anchor bolts. There shall be a mini-

um of two No. 4 lateral ties provided in the top 5 inches (127 mm) of the column.

R606.12.2.2.3 Minimum reinforcement requirements for masonry shear walls. Vertical reinforcement of at least one No. 4 bar shall be provided at corners, within 16 inches (406 mm) of each side of openings, within 8 inches (203 mm) of each side of movement joints, within 8 inches (203 mm) of the ends of walls, and at a maximum spacing of 10 feet (3048 mm).

Horizontal joint reinforcement shall consist of at least two wires of W1.7 spaced not more than 16 inches (406 mm); or bond beam reinforcement of at least one No. 4 bar spaced not more than 10 feet (3048 mm) shall be provided. Horizontal reinforcement shall also be provided at the bottom and top of wall openings and shall extend not less than 24 inches (610 mm) nor less than 40 bar diameters past the opening; continuously at structurally connected roof and floor levels; and within 16 inches (406 mm) of the top of walls.

R606.12.3 Seismic Design Category D₀ or D₁. Structures in Seismic Design Category D₀ or D₁ shall comply with the requirements of Seismic Design Category C and the additional requirements of this section.

R606.12.3.1 Design requirements. Masonry elements other than those covered by Section R606.12.2.1.2 shall be designed in accordance with the requirements of Chapter 1 and Sections 2.1 and 2.3 of ACI 530/ASCE 5/TMS 402 and shall meet the minimum reinforcement requirements contained in Sections R606.12.3.2 and R606.12.3.2.1.

Exception: Masonry walls limited to one story in height and 9 feet (2743 mm) between lateral supports need not be designed provided they comply with the minimum reinforcement requirements of Sections R606.12.3.2 and R606.12.3.2.1.

R606.12.3.2 Minimum reinforcement requirements for masonry walls. Masonry walls other than those covered by Section R606.12.2.1.3 shall be reinforced in both the vertical and horizontal direction. The sum of the cross-sectional area of horizontal and vertical reinforcement shall be at least 0.002 times the gross cross-sectional area of the wall, and the minimum cross-sectional area in each direction shall be not less than 0.0007 times the gross cross-sectional area of the wall. Reinforcement shall be uniformly distributed. Table R606.12.3.2 shows the minimum reinforcing bar sizes required for varying thicknesses of masonry walls. The maximum spacing of reinforcement shall be 48 inches (1219 mm) provided that the walls are solid grouted and constructed of hollow open-end units, hollow units laid with full head joints or two wythes of solid units. The maximum spacing of reinforcement shall be 24 inches (610 mm) for all other masonry.

R606.12.3.2.1 Shear wall reinforcement requirements. The maximum spacing of vertical and horizontal reinforcement shall be the smaller of one-third the length of the shear wall, one-third the height of the

TABLE R606.12.3.2
MINIMUM DISTRIBUTED WALL REINFORCEMENT FOR BUILDING ASSIGNED TO SEISMIC DESIGN CATEGORY D₀ or D₁

NOMINAL WALL THICKNESS (inches)	MINIMUM SUM OF THE VERTICAL AND HORIZONTAL REINFORCEMENT AREAS ^a (square inches per foot)	MINIMUM REINFORCEMENT AS DISTRIBUTED IN BOTH HORIZONTAL AND VERTICAL DIRECTIONS ^b (square inches per foot)	MINIMUM BAR SIZE FOR REINFORCEMENT SPACED AT 48 INCHES
6	0.135	0.047	#4
8	0.183	0.064	#5
10	0.231	0.081	#6
12	0.279	0.098	#6

For SI: 1 inch = 25.4 mm, 1 foot = 304.8 mm, 1 square inch per foot = 2064 mm²/m.

a. Based on the minimum reinforcing ratio of 0.002 times the gross cross-sectional area of the wall.

b. Based on the minimum reinforcing ratio each direction of 0.0007 times the gross cross-sectional area of the wall.

shear wall, or 48 inches (1219 mm). The minimum cross-sectional area of vertical reinforcement shall be one-third of the required shear reinforcement. Shear reinforcement shall be anchored around vertical reinforcing bars with a standard hook.

R606.12.3.3 Minimum reinforcement for masonry columns. Lateral ties in masonry columns shall be spaced not more than 8 inches (203 mm) on center and shall be at least $\frac{3}{8}$ inch (9.5 mm) diameter. Lateral ties shall be embedded in grout.

R606.12.3.4 Material restrictions. Type N mortar or masonry cement shall not be used as part of the lateral-force-resisting system.

R606.12.3.5 Lateral tie anchorage. Standard hooks for lateral tie anchorage shall be either a 135-degree (2.4 rad) standard hook or a 180-degree (3.2 rad) standard hook.

R606.12.4 Seismic Design Category D₂. All structures in Seismic Design Category D₂ shall comply with the requirements of Seismic Design Category D₁ and to the additional requirements of this section.

R606.12.4.1 Design of elements not part of the lateral-force-resisting system. Stack bond masonry that is not part of the lateral-force-resisting system shall have a horizontal cross-sectional area of reinforcement of at least 0.0015 times the gross cross-sectional area of masonry. Table R606.12.4.1 shows minimum reinforcing bar sizes for masonry walls. The maximum spacing of horizontal reinforcement shall be 24 inches (610 mm). These elements shall be solidly grouted and shall be constructed of hollow open-end units or two wythes of solid units.

TABLE R606.12.4.1
**MINIMUM REINFORCING FOR STACKED BONDED
MASONRY WALLS IN SEISMIC DESIGN CATEGORY D₂**

NOMINAL WALL THICKNESS (inches)	MINIMUM BAR SIZE SPACED AT 24 INCHES
6	#4
8	#5
10	#5
12	#6

For SI: 1 inch = 25.4 mm.

R606.12.4.2 Design of elements part of the lateral-force-resisting system. Stack bond masonry that

is part of the lateral-force-resisting system shall have a horizontal cross-sectional area of reinforcement of at least 0.0025 times the gross cross-sectional area of masonry. Table R606.12.4.2 shows minimum reinforcing bar sizes for masonry walls. The maximum spacing of horizontal reinforcement shall be 16 inches (406 mm). These elements shall be solidly grouted and shall be constructed of hollow open-end units or two wythes of solid units.

TABLE R606.12.4.2
**MINIMUM REINFORCING FOR STACKED BONDED MASONRY
WALLS IN SEISMIC DESIGN CATEGORY D₂**

NOMINAL WALL THICKNESS (inches)	MINIMUM BAR SIZE SPACED AT 16 INCHES
6	#4
8	#5
10	#5
12	#6

For SI: 1 inch = 25.4 mm.

R606.13 Protection for reinforcement. Bars shall be completely embedded in mortar or grout. Joint reinforcement embedded in horizontal mortar joints shall not have less than $\frac{5}{8}$ -inch (15.9 mm) mortar coverage from the exposed face. All other reinforcement shall have a minimum coverage of one bar diameter over all bars, but not less than $\frac{3}{4}$ inch (19 mm), except where exposed to weather or soil, in which case the minimum coverage shall be 2 inches (51 mm).

R606.14 Beam supports. Beams, girders or other concentrated loads supported by a wall or column shall have a bearing of at least 3 inches (76 mm) in length measured parallel to the beam upon solid masonry not less than 4 inches (102 mm) in thickness, or upon a metal bearing plate of adequate design and dimensions to distribute the load safely, or upon a continuous reinforced masonry member projecting not less than 4 inches (102 mm) from the face of the wall.

R606.14.1 Joist bearing. Joists shall have a bearing of not less than 1½ inches (38 mm), except as provided in Section R606.14, and shall be supported in accordance with Figure R606.11(1).

R606.15 Metal accessories. Joint reinforcement, anchors, ties and wire fabric shall conform to the following: ASTM A 82 for wire anchors and ties; ASTM A 36 for plate, headed and

bent-bar anchors; ASTM A 510 for corrugated sheet metal anchors and ties; ASTM A 951 for joint reinforcement; ASTM B 227 for copper-clad steel wire ties; or ASTM A 167 for stainless steel hardware.

R606.15.1 Corrosion protection. Minimum corrosion protection of joint reinforcement, anchor ties and wire fabric for use in masonry wall construction shall conform to Table R606.15.1.

**TABLE R606.15.1
MINIMUM CORROSION PROTECTION**

MASONRY METAL ACCESSORY	STANDARD
Joint reinforcement, interior walls	ASTM A 641, Class 1
Wire ties or anchors in exterior walls completely embedded in mortar or grout	ASTM A 641, Class 3
Wire ties or anchors in exterior walls not completely embedded in mortar or grout	ASTM A 153, Class B-2
Joint reinforcement in exterior walls or interior walls exposed to moist environment	ASTM A 153, Class B-2
Sheet metal ties or anchors exposed to weather	ASTM A 153, Class B-2
Sheet metal ties or anchors completely embedded in mortar or grout	ASTM A 653, Coating Designation G60
Stainless steel hardware for any exposure	ASTM A 167, Type 304

**SECTION R607
UNIT MASONRY**

R607.1 Mortar. Mortar for use in masonry construction shall comply with ASTM C 270. The type of mortar shall be in accordance with Sections R607.1.1, R607.1.2 and R607.1.3 and shall meet the proportion specifications of Table R607.1 or the property specifications of ASTM C 270.

R607.1.1 Foundation walls. Masonry foundation walls constructed as set forth in Tables R404.1.1(1) through R404.1.1(4) and mortar shall be Type M or S.

R607.1.2 Masonry in Seismic Design Categories A, B and C. Mortar for masonry serving as the lateral-force-resisting system in Seismic Design Categories A, B and C shall be Type M, S or N mortar.

R607.1.3 Masonry in Seismic Design Categories D₀, D₁ and D₂. Mortar for masonry serving as the lateral-force-resisting system in Seismic Design Categories D₀, D₁ and D₂ shall be Type M or S portland cement-lime or mortar cement mortar.

R607.2 Placing mortar and masonry units.

R607.2.1 Bed and head joints. Unless otherwise required or indicated on the project drawings, head and bed joints shall be 3/8 inch (10 mm) thick, except that the thickness of the bed joint of the starting course placed over foundations shall not be less than 1/4 inch (7 mm) and not more than 3/4 inch (19 mm).

R607.2.1.1 Mortar joint thickness tolerance. Mortar joint thickness shall be within the following tolerances from the specified dimensions:

1. Bed joint: + 1/8 inch (3 mm).
2. Head joint: 1/4 inch (7 mm), + 3/8 inch (10 mm).
3. Collar joints: 1/4 inch (7 mm), + 3/8 inch (10 mm).

Exception: Nonload-bearing masonry elements and masonry veneers designed and constructed in accordance with Section R703.7 are not required to meet these tolerances.

R607.2.2 Masonry unit placement. The mortar shall be sufficiently plastic and units shall be placed with sufficient pressure to extrude mortar from the joint and produce a tight joint. Deep furrowing of bed joints that produces voids shall not be permitted. Any units disturbed to the extent that initial bond is broken after initial placement shall be removed and relaid in fresh mortar. Surfaces to be in contact with mortar shall be clean and free of deleterious materials.

R607.2.2.1 Solid masonry. Solid masonry units shall be laid with full head and bed joints and all interior vertical joints that are designed to receive mortar shall be filled.

R607.2.2.2 Hollow masonry. For hollow masonry units, head and bed joints shall be filled solidly with mortar for a distance in from the face of the unit not less than the thickness of the face shell.

R607.3 Installation of wall ties. The installation of wall ties shall be as follows:

1. The ends of wall ties shall be embedded in mortar joints. Wall tie ends shall engage outer face shells of hollow units by at least 1/2 inch (13 mm). Wire wall ties shall be embedded at least 1 1/2 inches (38 mm) into the mortar bed of solid masonry units or solid grouted hollow units.
2. Wall ties shall not be bent after being embedded in grout or mortar.

**SECTION R608
MULTIPLE WYTHE MASONRY**

R608.1 General. The facing and backing of multiple wythe masonry walls shall be bonded in accordance with Section R608.1.1, R608.1.2 or R608.1.3. In cavity walls, neither the facing nor the backing shall be less than 3 inches (76 mm) nominal in thickness and the cavity shall not be more than 4 inches (102 mm) nominal in width. The backing shall be at least as thick as the facing.

Exception: Cavities shall be permitted to exceed the 4-inch (102 mm) nominal dimension provided tie size and tie spacing have been established by calculation.

R608.1.1 Bonding with masonry headers. Bonding with solid or hollow masonry headers shall comply with Sections R608.1.1.1 and R608.1.1.2.

R608.1.1.1 Solid units. Where the facing and backing (adjacent wythes) of solid masonry construction are bonded by means of masonry headers, no less than 4 percent of the wall surface of each face shall be composed of

TABLE R607.1
MORTAR PROPORTIONS^{a, b}

		PROPORTIONS BY VOLUME (cementitious materials)								Aggregate ratio (measured in damp, loose conditions)
MORTAR	TYPE	Portland cement or blended cement	Mortar cement			Masonry cement			Hydrated lime ^c or lime putty	
			M	S	N	M	S	N		
Cement-lime	M	1	—	—	—	—	—	—	1/4	Not less than 2 1/4 and not more than 3 times the sum of separate volumes of lime, if used, and cement
	S	1	—	—	—	—	—	—	over 1/4 to 1/2	
	N	1	—	—	—	—	—	—	over 1/2 to 1 1/4	
	O	1	—	—	—	—	—	—	over 1 1/4 to 2 1/2	
Mortar cement	M	1	—	—	1	—	—	—	—	
	M	—	1	—	—	—	—	—		
	S	1/2	—	—	1	—	—	—		
	S	—	—	1	—	—	—	—		
	N	—	—	—	1	—	—	—		
Masonry cement	O	—	—	—	1	—	—	—	—	
	M	1	—	—	—	—	1	—		
	M	—	—	—	1	—	—			
	S	1/2	—	—	—	—	1			
	S	—	—	—	—	1	—			
	N	—	—	—	—	—	1			
O	—	—	—	—	—	1				

For SI: 1 cubic foot = 0.0283 m³, 1 pound = 0.454 kg.

a. For the purpose of these specifications, the weight of 1 cubic foot of the respective materials shall be considered to be as follows:

Portland Cement	94 pounds	Masonry Cement	Weight printed on bag
Mortar Cement	Weight printed on bag	Hydrated Lime	40 pounds
Lime Putty (Quicklime)	80 pounds	Sand, damp and loose	80 pounds of dry sand

b. Two air-entraining materials shall not be combined in mortar.

c. Hydrated lime conforming to the requirements of ASTM C 207.

headers extending not less than 3 inches (76 mm) into the backing. The distance between adjacent full-length headers shall not exceed 24 inches (610 mm) either vertically or horizontally. In walls in which a single header does not extend through the wall, headers from the opposite sides shall overlap at least 3 inches (76 mm), or headers from opposite sides shall be covered with another header course overlapping the header below at least 3 inches (76 mm).

R608.1.1.2 Hollow units. Where two or more hollow units are used to make up the thickness of a wall, the stretcher courses shall be bonded at vertical intervals not exceeding 34 inches (864 mm) by lapping at least 3 inches (76 mm) over the unit below, or by lapping at vertical intervals not exceeding 17 inches (432 mm) with units that are at least 50 percent thicker than the units below.

R608.1.2 Bonding with wall ties or joint reinforcement.

Bonding with wall ties or joint reinforcement shall comply with Sections R608.1.2.1 through R608.1.2.3.

R608.1.2.1 Bonding with wall ties. Bonding with wall ties, except as required by Section R610, where the facing and backing (adjacent wythes) of masonry walls are bonded with 3/16-inch-diameter (5 mm) wall ties embedded in the horizontal mortar joints, there shall be at least one metal tie for each 4.5 square feet (0.418 m²) of wall area. Ties in alternate courses shall be staggered. The maximum vertical distance between ties shall not exceed 24 inches (610 mm), and the maximum horizontal dis-

tance shall not exceed 36 inches (914 mm). Rods or ties bent to rectangular shape shall be used with hollow masonry units laid with the cells vertical. In other walls, the ends of ties shall be bent to 90-degree (0.79 rad) angles to provide hooks no less than 2 inches (51 mm) long. Additional bonding ties shall be provided at all openings, spaced not more than 3 feet (914 mm) apart around the perimeter and within 12 inches (305 mm) of the opening.

R608.1.2.2 Bonding with adjustable wall ties. Where the facing and backing (adjacent wythes) of masonry are bonded with adjustable wall ties, there shall be at least one tie for each 2.67 square feet (0.248 m²) of wall area. Neither the vertical nor the horizontal spacing of the adjustable wall ties shall exceed 24 inches (610 mm). The maximum vertical offset of bed joints from one wythe to the other shall be 1.25 inches (32 mm). The maximum clearance between connecting parts of the ties shall be 1/16 inch (2 mm). When pintle legs are used, ties shall have at least two 3/16-inch-diameter (5 mm) legs.

R608.1.2.3 Bonding with prefabricated joint reinforcement. Where the facing and backing (adjacent wythes) of masonry are bonded with prefabricated joint reinforcement, there shall be at least one cross wire serving as a tie for each 2.67 square feet (0.248 m²) of wall area. The vertical spacing of the joint reinforcement shall not exceed 16 inches (406 mm). Cross wires on prefabricated joint reinforcement shall not be smaller than No. 9 gage. The longitudinal wires shall be embedded in the mortar.

R608.1.3 Bonding with natural or cast stone. Bonding with natural and cast stone shall conform to Sections R608.1.3.1 and R608.1.3.2.

R608.1.3.1 Ashlar masonry. In ashlar masonry, bonder units, uniformly distributed, shall be provided to the extent of not less than 10 percent of the wall area. Such bonder units shall extend not less than 4 inches (102 mm) into the backing wall.

R608.1.3.2 Rubble stone masonry. Rubble stone masonry 24 inches (610 mm) or less in thickness shall have bonder units with a maximum spacing of 3 feet (914 mm) vertically and 3 feet (914 mm) horizontally, and if the masonry is of greater thickness than 24 inches (610 mm), shall have one bonder unit for each 6 square feet (0.557 m²) of wall surface on both sides.

R608.2 Masonry bonding pattern. Masonry laid in running and stack bond shall conform to Sections R608.2.1 and R608.2.2.

R608.2.1 Masonry laid in running bond. In each wythe of masonry laid in running bond, head joints in successive courses shall be offset by not less than one-fourth the unit length, or the masonry walls shall be reinforced longitudinally as required in Section R608.2.2.

R608.2.2 Masonry laid in stack bond. Where unit masonry is laid with less head joint offset than in Section

R607.2.1, the minimum area of horizontal reinforcement placed in mortar bed joints or in bond beams spaced not more than 48 inches (1219 mm) apart, shall be 0.0007 times the vertical cross-sectional area of the wall.

**SECTION R609
GROUTED MASONRY**

R609.1 General. Grouted multiple-wythe masonry is a form of construction in which the space between the wythes is solidly filled with grout. It is not necessary for the cores of masonry units to be filled with grout. Grouted hollow unit masonry is a form of construction in which certain cells of hollow units are continuously filled with grout.

R609.1.1 Grout. Grout shall consist of cementitious material and aggregate in accordance with ASTM C 476 and the proportion specifications of Table R609.1.1. Type M or Type S mortar to which sufficient water has been added to produce pouring consistency can be used as grout.

R609.1.2 Grouting requirements. Maximum pour heights and the minimum dimensions of spaces provided for grout placement shall conform to Table R609.1.2. If the work is stopped for one hour or longer, the horizontal construction joints shall be formed by stopping all tiers at the same elevation and with the grout 1 inch (25 mm) below the top.

**TABLE R609.1.1
GROUT PROPORTIONS BY VOLUME FOR MASONRY CONSTRUCTION**

TYPE	PORTLAND CEMENT OR BLENDED CEMENT SLAG CEMENT	HYDRATED LIME OR LIME PUTTY	AGGREGATE MEASURED IN A DAMP, LOOSE CONDITION	
			Fine	Coarse
Fine	1	0 to 1/10	2 ¹ / ₄ to 3 times the sum of the volume of the cementitious materials	—
Coarse	1	0 to 1/10	2 ¹ / ₄ to 3 times the sum of the volume of the cementitious materials	1 to 2 times the sum of the volumes of the cementitious materials

**TABLE R609.1.2
GROUT SPACE DIMENSIONS AND POUR HEIGHTS**

GROUT TYPE	GROUT POUR MAXIMUM HEIGHT (feet)	MINIMUM WIDTH OF GROUT SPACES ^{a,b} (inches)	MINIMUM GROUT ^{b,c} SPACE DIMENSIONS FOR GROUTING CELLS OF HOLLOW UNITS (inches x inches)
Fine	1	0.75	1.5 x 2
	5	2	2 x 3
	12	2.5	2.5 x 3
	24	3	3 x 3
Coarse	1	1.5	1.5 x 3
	5	2	2.5 x 3
	12	2.5	3 x 3
	24	3	3 x 4

For SI: 1 inch = 25.4 mm, 1 foot = 304.8 mm.

a. For grouting between masonry wythes.

b. Grout space dimension is the clear dimension between any masonry protrusion and shall be increased by the horizontal projection of the diameters of the horizontal bars within the cross section of the grout space.

c. Area of vertical reinforcement shall not exceed 6 percent of the area of the grout space.

R609.1.3 Grout space (cleaning). Provision shall be made for cleaning grout space. Mortar projections that project more than 0.5 inch (13 mm) into grout space and any other foreign matter shall be removed from grout space prior to inspection and grouting.

R609.1.4 Grout placement. Grout shall be a plastic mix suitable for pumping without segregation of the constituents and shall be mixed thoroughly. Grout shall be placed by pumping or by an approved alternate method and shall be placed before any initial set occurs and in no case more than 1½ hours after water has been added. Grouting shall be done in a continuous pour, in lifts not exceeding 5 feet (1524 mm). It shall be consolidated by puddling or mechanical vibrating during placing and reconsolidated after excess moisture has been absorbed but before plasticity is lost.

R609.1.4.1 Grout pumped through aluminum pipes. Grout shall not be pumped through aluminum pipes.

R609.1.5 Cleanouts. Where required by the building official, cleanouts shall be provided as specified in this section. The cleanouts shall be sealed before grouting and after inspection.

R609.1.5.1 Grouted multiple-wythe masonry. Cleanouts shall be provided at the bottom course of the exterior wythe at each pour of grout where such pour exceeds 5 feet (1524 mm) in height.

R609.1.5.2 Grouted hollow unit masonry. Cleanouts shall be provided at the bottom course of each cell to be grouted at each pour of grout, where such pour exceeds 4 feet (1219 mm) in height.

R609.2 Grouted multiple-wythe masonry. Grouted multiple-wythe masonry shall conform to all the requirements specified in Section R609.1 and the requirements of this section.

R609.2.1 Bonding of backup wythe. Where all interior vertical spaces are filled with grout in multiple-wythe construction, masonry headers shall not be permitted. Metal wall ties shall be used in accordance with Section R608.1.2 to prevent spreading of the wythes and to maintain the vertical alignment of the wall. Wall ties shall be installed in accordance with Section R608.1.2 when the backup wythe in multiple-wythe construction is fully grouted.

R609.2.2 Grout spaces. Fine grout shall be used when interior vertical space to receive grout does not exceed 2 inches (51 mm) in thickness. Interior vertical spaces exceeding 2 inches (51 mm) in thickness shall use coarse or fine grout.

R609.2.3 Grout barriers. Vertical grout barriers or dams shall be built of solid masonry across the grout space the entire height of the wall to control the flow of the grout horizontally. Grout barriers shall not be more than 25 feet (7620 mm) apart. The grouting of any section of a wall between control barriers shall be completed in one day with no interruptions greater than one hour.

R609.3 Reinforced grouted multiple-wythe masonry. Reinforced grouted multiple-wythe masonry shall conform to all the requirements specified in Sections R609.1 and R609.2 and the requirements of this section.

R609.3.1 Construction. The thickness of grout or mortar between masonry units and reinforcement shall not be less than ¼ inch (7 mm), except that ¼-inch (7 mm) bars may be laid in horizontal mortar joints at least ½ inch (13 mm) thick, and steel wire reinforcement may be laid in horizontal mortar joints at least twice the thickness of the wire diameter.

R609.4 Reinforced hollow unit masonry. Reinforced hollow unit masonry shall conform to all the requirements of Section R609.1 and the requirements of this section.

R609.4.1 Construction. Requirements for construction shall be as follows:

1. Reinforced hollow-unit masonry shall be built to preserve the unobstructed vertical continuity of the cells to be filled. Walls and cross webs forming cells to be filled shall be full-bedded in mortar to prevent leakage of grout. Head and end joints shall be solidly filled with mortar for a distance in from the face of the wall or unit not less than the thickness of the longitudinal face shells. Bond shall be provided by lapping units in successive vertical courses.
2. Cells to be filled shall have vertical alignment sufficient to maintain a clear, unobstructed continuous vertical cell of dimensions prescribed in Table R609.1.2.
3. Vertical reinforcement shall be held in position at top and bottom and at intervals not exceeding 200 diameters of the reinforcement.
4. Cells containing reinforcement shall be filled solidly with grout. Grout shall be poured in lifts of 8-foot (2438 mm) maximum height. When a total grout pour exceeds 8 feet (2438 mm) in height, the grout shall be placed in lifts not exceeding 5 feet (1524 mm) and special inspection during grouting shall be required.
5. Horizontal steel shall be fully embedded by grout in an uninterrupted pour.

SECTION R610 GLASS UNIT MASONRY

R610.1 General. Panels of glass unit masonry located in load-bearing and nonload-bearing exterior and interior walls shall be constructed in accordance with this section.

R610.2 Materials. Hollow glass units shall be partially evacuated and have a minimum average glass face thickness of ⅜ inch (5 mm). The surface of units in contact with mortar shall be treated with a polyvinyl butyral coating or latex-based paint. The use of reclaimed units is prohibited.

R610.3 Units. Hollow or solid glass block units shall be standard or thin units.

R610.3.1 Standard units. The specified thickness of standard units shall be at least ⅜ inches (98 mm).

R610.3.2 Thin units. The specified thickness of thin units shall be at least ⅜ inches (79 mm) for hollow units and at least 3 inches (76 mm) for solid units.

R610.4 Isolated panels. Isolated panels of glass unit masonry shall conform to the requirements of this section.

R610.4.1 Exterior standard-unit panels. The maximum area of each individual standard-unit panel shall be 144 square feet (13.4 m²) when the design wind pressure is 20 psf (958 Pa). The maximum area of such panels subjected to design wind pressures other than 20 psf (958 Pa) shall be in accordance with Figure R610.4.1. The maximum panel dimension between structural supports shall be 25 feet (7620 mm) in width or 20 feet (6096 mm) in height.

R610.4.2 Exterior thin-unit panels. The maximum area of each individual thin-unit panel shall be 85 square feet (7.9 m²). The maximum dimension between structural supports shall be 15 feet (4572 mm) in width or 10 feet (3048 mm) in height. Thin units shall not be used in applications where the design wind pressure as stated in Table R301.2(1) exceeds 20 psf (958 Pa).

R610.4.3 Interior panels. The maximum area of each individual standard-unit panel shall be 250 square feet (23.2 m²). The maximum area of each thin-unit panel shall be 150 square feet (13.9 m²). The maximum dimension between structural supports shall be 25 feet (7620 mm) in width or 20 feet (6096 mm) in height.

R610.4.4 Curved panels. The width of curved panels shall conform to the requirements of Sections R610.4.1, R610.4.2 and R610.4.3, except additional structural supports shall be provided at locations where a curved section joins a straight section, and at inflection points in multicurved walls.

R610.5 Panel support. Glass unit masonry panels shall conform to the support requirements of this section.

R610.5.1 Deflection. The maximum total deflection of structural members that support glass unit masonry shall not exceed $1/600$.

R610.5.2 Lateral support. Glass unit masonry panels shall be laterally supported along the top and sides of the panel. Lateral supports for glass unit masonry panels shall be designed to resist a minimum of 200 pounds per lineal feet (2918 N/m) of panel, or the actual applied loads, whichever is greater. Except for single unit panels, lateral support shall be provided by panel anchors along the top and sides spaced a maximum of 16 inches (406 mm) on center or by channel-type restraints. Single unit panels shall be supported by channel-type restraints.

Exceptions:

1. Lateral support is not required at the top of panels that are one unit wide.
2. Lateral support is not required at the sides of panels that are one unit high.

R610.5.2.1 Panel anchor restraints. Panel anchors shall be spaced a maximum of 16 inches (406 mm) on center in both jambs and across the head. Panel anchors shall be embedded a minimum of 12 inches (305 mm) and shall be provided with two fasteners so as to resist the loads specified in Section R610.5.2.

R610.5.2.2 Channel-type restraints. Glass unit masonry panels shall be recessed at least 1 inch (25 mm) within channels and chases. Channel-type restraints shall be oversized to accommodate expansion material in the opening, packing and sealant between

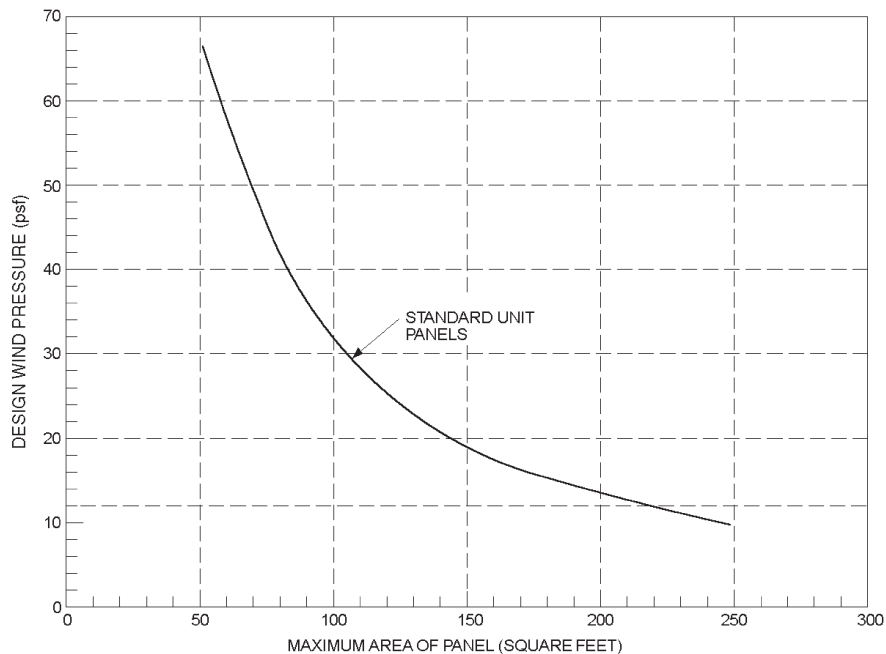

For SI: 1 square foot = 0.0929 m², 1 pound per square foot = 0.0479 kPa.

FIGURE R610.4.1
GLASS UNIT MASONRY DESIGN WIND LOAD RESISTANCE

the framing restraints, and the glass unit masonry perimeter units.

R610.6 Sills. Before bedding of glass units, the sill area shall be covered with a water base asphaltic emulsion coating. The coating shall be a minimum of $\frac{1}{8}$ inch (3 mm) thick.

R610.7 Expansion joints. Glass unit masonry panels shall be provided with expansion joints along the top and sides at all structural supports. Expansion joints shall be a minimum of $\frac{3}{8}$ inch (10 mm) in thickness and shall have sufficient thickness to accommodate displacements of the supporting structure. Expansion joints shall be entirely free of mortar and other debris and shall be filled with resilient material.

R610.8 Mortar. Glass unit masonry shall be laid with Type S or N mortar. Mortar shall not be retempered after initial set. Mortar unused within $1\frac{1}{2}$ hours after initial mixing shall be discarded.

R610.9 Reinforcement. Glass unit masonry panels shall have horizontal joint reinforcement spaced a maximum of 16 inches (406 mm) on center located in the mortar bed joint. Horizontal joint reinforcement shall extend the entire length of the panel but shall not extend across expansion joints. Longitudinal wires shall be lapped a minimum of 6 inches (152 mm) at splices. Joint reinforcement shall be placed in the bed joint immediately below and above openings in the panel. The reinforcement shall have not less than two parallel longitudinal wires of size W1.7 or greater, and have welded cross wires of size W1.7 or greater.

R610.10 Placement. Glass units shall be placed so head and bed joints are filled solidly. Mortar shall not be furrowed. Head and bed joints of glass unit masonry shall be $\frac{1}{4}$ inch (6.4 mm) thick, except that vertical joint thickness of radial panels shall not be less than $\frac{1}{8}$ inch (3 mm) or greater than $\frac{5}{8}$ inch (16 mm). The bed joint thickness tolerance shall be minus $\frac{1}{16}$ inch (1.6 mm) and plus $\frac{1}{8}$ inch (3 mm). The head joint thickness tolerance shall be plus or minus $\frac{1}{8}$ inch (3 mm).

SECTION R611 INSULATING CONCRETE FORM WALL CONSTRUCTION

R611.1 General. Insulating Concrete Form (ICF) walls shall be designed and constructed in accordance with the provisions of this section or in accordance with the provisions of ACI 318. When ACI 318 or the provisions of this section are used to design insulating concrete form walls, project drawings, typical details and specifications are not required to bear the seal of the architect or engineer responsible for design, unless otherwise required by the state law of the jurisdiction having authority.

R611.2 Applicability limits. The provisions of this section shall apply to the construction of insulating concrete form walls for buildings not greater than 60 feet (18 288 mm) in plan dimensions, and floors not greater than 32 feet (9754 mm) or roofs not greater than 40 feet (12 192 mm) in clear span. Buildings shall not exceed two stories in height above-grade. ICF walls shall comply with the requirements in Table R611.2. Walls constructed in accordance with the provisions of this section shall be limited to buildings subjected to a maximum design wind speed of 150 miles per hour (67 m/s), and Seismic Design Categories A, B, C, D₀, D₁ and D₂. The provisions of this section shall not apply to the construction of ICF walls for buildings or portions of buildings considered irregular as defined in Section R301.2.2.2.2.

For townhouses in Seismic Design Category C and all buildings in Seismic Design Category D₀, D₁ or D₂, the provisions of this section shall apply only to buildings meeting the following requirements.

1. Rectangular buildings with a maximum building aspect ratio of 2:1. The building aspect ratio shall be determined by dividing the longest dimension of the building by the shortest dimension of the building.
2. Walls are aligned vertically with the walls below.

TABLE R611.2
REQUIREMENTS FOR ICF WALLS^b

WALL TYPE AND NOMINAL SIZE	MAXIMUM WALL WEIGHT (psf) ^c	MINIMUM WIDTH OF VERTICAL CORE (inches) ^a	MINIMUM THICKNESS OF VERTICAL CORE (inches) ^a	MAXIMUM SPACING OF VERTICAL CORES (inches)	MAXIMUM SPACING OF HORIZONTAL CORES (inches)	MINIMUM WEB THICKNESS (inches)
3.5" Flat ^d	44 ^d	N/A	N/A	N/A	N/A	N/A
5.5" Flat	69	N/A	N/A	N/A	N/A	N/A
7.5" Flat	94	N/A	N/A	N/A	N/A	N/A
9.5" Flat	119	N/A	N/A	N/A	N/A	N/A
6" Waffle-Grid	56	6.25	5	12	16	2
8" Waffle-Grid	76	7	7	12	16	2
6" Screen-Grid	53	5.5	5.5	12	12	N/A

For SI: 1 inch = 25.4 mm; 1 pound per cubic foot = 16.018 kg/m³; 1 pound per square foot = 0.0479 kPa.

a. For width "W", thickness "T", spacing, and web thickness, refer to Figures R611.4 and R611.5.

b. N/A indicates not applicable.

c. Wall weight is based on a unit weight of concrete of 150 pcf. The tabulated values do not include any allowance for interior and exterior finishes.

d. For all buildings in Seismic Design Category A or B, and detached one- and two-family dwellings in Seismic Design Category C the actual wall thickness is permitted to be up to 1 inch thicker than shown and the maximum wall weight to be 56 psf. Construction requirements and other limitations within Section R611 for 3.5-inch flat ICF walls shall apply. Interpolation between provisions for 3.5-inch and 5.5-inch flat ICF walls is not permitted.

WALL CONSTRUCTION

3. Cantilever and setback construction shall not be permitted.
4. The weight of interior and exterior finishes applied to ICF walls shall not exceed 8 psf (380 Pa).
5. The gable portion of ICF walls shall be constructed of light-frame construction.

R611.3 Flat insulating concrete form wall systems. Flat ICF wall systems shall comply with Figure R611.3 and shall have reinforcement in accordance with Tables R611.3(1) and R611.3(2) and Section R611.7.

R611.4 Waffle-grid insulating concrete form wall systems. Waffle-grid wall systems shall comply with Figure R611.4 and shall have reinforcement in accordance with Tables R611.3(1)

and R611.4(1) and Section R611.7. The minimum core dimensions shall comply with Table R611.2.

R611.5 Screen-grid insulating concrete form wall systems. Screen-grid ICF wall systems shall comply with Figure R611.5 and shall have reinforcement in accordance with Tables R611.3(1) and R611.5 and Section R611.7. The minimum core dimensions shall comply with Table R611.2.

R611.6 Material. Insulating concrete form wall materials shall comply with this section.

R611.6.1 Concrete material. Ready-mixed concrete for insulating concrete form walls shall be in accordance with Section R402.2. Maximum slump shall not be greater than 6 inches (152 mm) as determined in accordance with ASTM

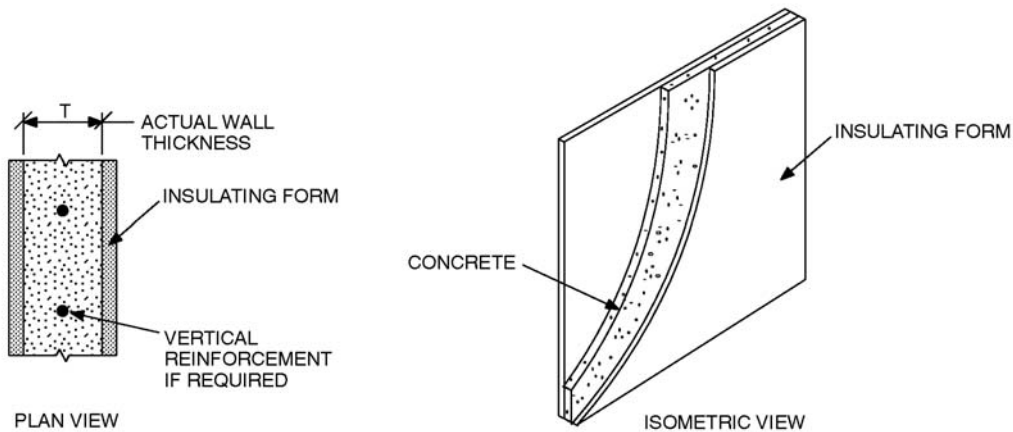

**FIGURE R611.3
FLAT ICF WALL SYSTEM**

**TABLE R611.3(1)
DESIGN WIND PRESSURE FOR USE WITH TABLES R611.3(2), R611.4(1), AND R611.5 FOR ABOVE GRADE WALLS^a**

WIND SPEED (mph) ^e	DESIGN WIND PRESSURE (psf)					
	Enclosed ^b			Partially Enclosed ^b		
	Exposure ^c			Exposure ^c		
	B	C	D	B	C	D
85	18	24	29	23	31	37
90	20	27	32	25	35	41
100	24	34	39	31	43	51
110	29	41	48	38	52	61
120	35	48	57	45	62	73
130	41	56	66	53	73	85 ^d
140	47	65	77	61	84 ^d	99 ^d
150	54	75	88 ^d	70	96 ^d	114 ^d

For SI: 1 pound per square foot = 0.0479 kPa; 1 mile per hour = 0.447 m/s; 1 foot = 304.8 mm; 1 square foot = 0.0929 m².

- a. This table is based on ASCE 7-98 components and cladding wind pressures using a mean roof height of 35 ft and a tributary area of 10 ft².
- b. Buildings in wind-borne debris regions as defined in Section R202 shall be considered as "Partially Enclosed" unless glazed openings are protected in accordance with Section R301.2.1.2, in which case the building shall be considered as "Enclosed." All other buildings shall be classified as "Enclosed."
- c. Exposure Categories shall be determined in accordance with Section R301.2.1.4.
- d. For wind pressures greater than 80 psf, design is required in accordance with ACI 318 and approved manufacturer guidelines.
- e. Interpolation is permitted between wind speeds.

C 143. Maximum aggregate size shall not be larger than 3/4 inch (19 mm).

Exception: Concrete mixes conforming to the ICF manufacturer’s recommendations.

In Seismic Design Categories D₀, D₁ and D₂, the minimum concrete compressive strength shall be 3,000 psi (20.5 MPa).

R611.6.2 Reinforcing steel. Reinforcing steel shall meet the requirements of ASTM A 615, A 706, or A 996. Except in Seismic Design Categories D₀, D₁ and D₂, the minimum yield strength of reinforcing steel shall be 40,000 psi (Grade 40) (276 MPa). In Seismic Design Categories D₀, D₁ and D₂, reinforcing steel shall meet the requirements of ASTM A 706 for low-alloy steel with a minimum yield strength of 60,000 psi (Grade 60) (414 Mpa).

TABLE R611.3(2)
MINIMUM VERTICAL WALL REINFORCEMENT FOR FLAT ICF ABOVE-GRADE WALLS^{a, b, c, d}

Design Wind Pressure [Table R611.3(1)] (psf)	Maximum Unsupported Wall Height (feet)	Minimum Vertical Reinforcement ^{d, e, f}					
		Nonload-Bearing Wall or Supporting Roof		Supporting Light-Framed Second Story and Roof		Supporting ICF Second Story and Roof	
		Minimum Wall Thickness (inches)					
		3.5 ^g	5.5	3.5 ^g	5.5	3.5 ^g	5.5
20	8	#4@48	#4@48	#4@48	#4@48	#4@48	#4@48
	9	#4@48	#4@48	#4@48	#4@48	#4@48	#4@48
	10	#4@38	#4@48	#4@40	#4@48	#4@42	#4@48
30	8	#4@42	#4@48	#4@46	#4@48	#4@48	#4@48
	9	#4@32; #5@48	#4@48	#4@34; #5@48	#4@48	#4@34; #5@48	#4@48
	10	Design Required	#4@48	Design Required	#4@48	Design Required	#4@48
40	8	#4@30; #5@48	#4@48	#4@30; #5@48	#4@48	#4@32; #5@48	#4@48
	9	Design Required	#4@42	Design Required	#4@46	Design Required	#4@48
	10	Design Required	#4@32; #5@48	Design Required	#4@34; #5@48	Design Required	#4@38
50	8	#4@20; #5@30	#4@42	#4@22; #5@34	#4@46	#4@24; #5@36	#4@48
	9	Design Required	#4@34; #5@48	Design Required	#4@34; #5@48	Design Required	#4@38
	10	Design Required	#4@26; #5@38	Design Required	#4@26; #5@38	Design Required	#4@28; #5@46
60	8	Design Required	#4@34; #5@48	Design Required	#4@36	Design Required	#4@40
	9	Design Required	#4@26; #5@38	Design Required	#4@28; #5@46	Design Required	#4@34; #5@48
	10	Design Required	#4@22; #5@34	Design Required	#4@22; #5@34	Design Required	#4@26; #5@38
70	8	Design Required	#4@28; #5@46	Design Required	#4@30; #5@48	Design Required	#4@34; #5@48
	9	Design Required	#4@22; #5@34	Design Required	#4@22; #5@34	Design Required	#4@24; #5@36
	10	Design Required	#4@16; #5@26	Design Required	#4@18; #5@28	Design Required	#4@20; #5@30
80	8	Design Required	#4@26; #5@38	Design Required	#4@26; #5@38	Design Required	#4@28; #5@46
	9	Design Required	#4@20; #5@30	Design Required	#4@20; #5@30	Design Required	#4@21; #5@34
	10	Design Required	#4@14; #5@24	Design Required	#4@14; #5@24	Design Required	#4@16; #5@26

For SI: 1 inch = 25.4 mm; 1 foot = 304.8 mm; 1 mile per hour = 0.447 m/s; 1 pound per square inch = 6.895 kPa.

a. This table is based on reinforcing bars with a minimum yield strength of 40,000 psi and concrete with a minimum specified compressive strength of 2,500 psi. For Seismic Design Categories D₀, D₁ and D₂, reinforcing bars shall have a minimum yield strength of 60,000 psi. See Section R611.6.2.

b. Deflection criterion is L/240, where L is the height of the wall story in inches.

c. Interpolation shall not be permitted.

d. Reinforcement spacing for 3.5 inch walls shall be permitted to be multiplied by 1.6 when reinforcing steel with a minimum yield strength of 60,000 psi is used. Reinforcement shall not be less than one #4 bar at 48 inches (1.2 m) on center.

e. Reinforcement spacing for 5.5 inch (139.7 mm) walls shall be permitted to be multiplied by 1.5 when reinforcing steel with a minimum yield strength of 60,000 psi is used. Reinforcement shall not be less than one #4 bar at 48 inches on center.

f. See Section R611.7.1.2 for limitations on maximum spacing of vertical reinforcement in Seismic Design Categories C, D₀, D₁ and D₂.

g. A 3.5-inch wall shall not be permitted if wood ledgers are used to support floor or roof loads. See Section R611.8.

TABLE R611.4(1)
MINIMUM VERTICAL WALL REINFORCEMENT FOR WAFFLE-GRID ICF ABOVE-GRADE WALLS^{a, b, c}

Design Wind Pressure [Table R611.3(1)] (psf)	Maximum Unsupported Wall Height (feet)	MINIMUM VERTICAL REINFORCEMENT ^{d, e}					
		Nonload-Bearing Wall or Supporting Roof		Supporting Light-Framed Second Story and Roof		Supporting ICF Second Story and Roof	
		Minimum Wall Thickness (inches)					
		6	8	6	8	6	8
20	8	#4@48	#4@48	#4@48	#4@48	#4@48	#4@48
	9	#4@48	#4@48	#4@48	#4@48	#4@48	#4@48
	10	#4@48	#4@48	#4@48	#4@48	#4@48	#4@48
30	8	#4@48	#4@48	#4@48	#4@48	#4@48	#4@48
	9	#4@48	#4@48	#4@48	#4@48	#4@48	#4@48
	10	#4@36; #5@48	#4@48	#4@36; #5@48	#4@48	#4@36; #5@48	#4@48
40	8	#4@36; #5@48	#4@48	#4@48	#4@48	#4@48	#4@48
	9	#4@36; #5@48	#4@48	#4@36; #5@48	#4@48	#4@36; #5@48	#4@48
	10	#4@24; #5@36	#4@36; #5@48	#4@24; #5@36	#4@48	#4@24; #5@36	#4@48
50	8	#4@36; #5@48	#4@48	#4@36; #5@48	#4@48	#4@36; #5@48	#4@48
	9	#4@24; #5@36	#4@36; #5@48	#4@24; #5@36	#4@48	#4@24; #5@48	#4@48
	10	Design Required	#4@36; #5@48	Design Required	#4@36; #5@48	Design Required	#4@36; #5@48
60	8	#4@24; #5@36	#4@48	#4@24; #5@36	#4@48	#4@24; #5@48	#4@48
	9	Design Required	#4@36; #5@48	Design Required	#4@36; #5@48	Design Required	#4@36; #5@48
	10	Design Required	#4@24; #5@36	Design Required	#4@24; #5@36	Design Required	#4@24; #5@48
70	8	#4@24; #5@36	#4@36; #5@48	#4@24; #5@36	#4@36; #5@48	#4@24; #5@36	#4@48
	9	Design Required	#4@24; #5@36	Design Required	#4@24; #5@48	Design Required	#4@24; #5@48
	10	Design Required	#4@12; #5@36	Design Required	#4@24; #5@36	Design Required	#4@24; #5@36
80	8	#4@12; #5@24	#4@24; #5@48	#4@12; #5@24	#4@24; #5@48	#4@12; #5@24	#4@36; #5@48
	9	Design Required	#4@24; #5@36	Design Required	#4@24; #5@36	Design Required	#4@24; #5@36
	10	Design Required	#4@12; #5@24	Design Required	#4@12; #5@24	Design Required	#4@12; #5@24

For SI: 1 foot = 304.8 mm; 1 inch = 25.4 mm; 1 mile per hour = 0.447 m/s; 1 pound per square inch = 6.895 MPa.

- a. This table is based on reinforcing bars with a minimum yield strength of 40,000 psi and concrete with a minimum specified compressive strength of 2,500 psi. For Seismic Design Categories D₀, D₁ and D₂, reinforcing bars shall have a minimum yield strength of 60,000 psi. See Section R611.6.2.
- b. Deflection criterion is $L/240$, where L is the height of the wall story in inches.
- c. Interpolation shall not be permitted.
- d. Increasing reinforcement spacing by 12 inches shall be permitted when reinforcing steel with a minimum yield strength of 60,000 psi is used or substitution of No. 4 reinforcing bars for #5 bars shall be permitted when reinforcing steel with a minimum yield strength of 60,000 psi is used at the same spacing required for #5 bars. Reinforcement shall not be less than one #4 bar at 48 inches on center.
- e. See Section R611.7.1.2 for limitations on maximum spacing of vertical reinforcement in Seismic Design Categories C, D₀, D₁ and D₂.

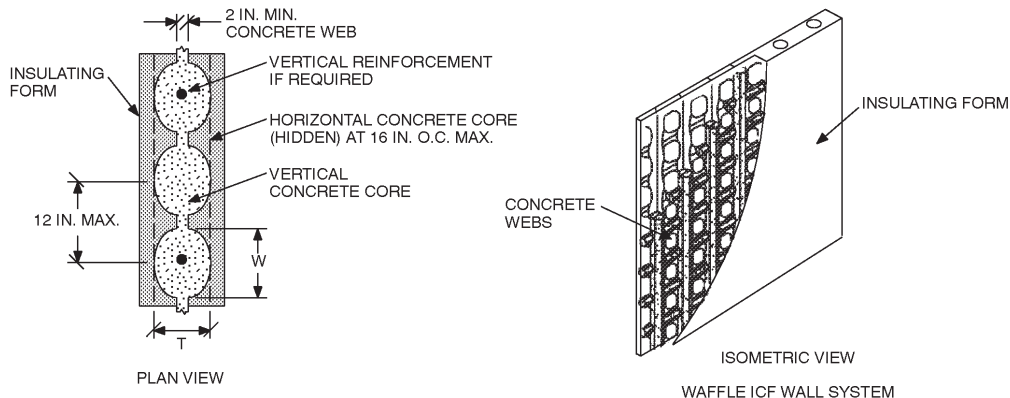

FIGURE R611.4
WAFFLE-GRID ICF WALL SYSTEM

TABLE R611.5
MINIMUM VERTICAL WALL REINFORCEMENT FOR SCREEN-GRID ICF ABOVE-GRADE WALLS^{a, b, c}

DESIGN WIND PRESSURE [TABLE R611.3(1)] (psf)	MAXIMUM UNSUPPORTED WALL HEIGHT (feet)	MINIMUM VERTICAL REINFORCEMENT ^{d, e}		
		Nonload-Bearing Wall or Supporting Roof	Supporting Light-Framed Second Story and Roof	Supporting ICF Second Story and Roof
20	8	#4@48	#4@48	#4@48
	9	#4@48	#4@48	#4@48
	10	#4@48	#4@48	#4@48
30	8	#4@48	#4@48	#4@48
	9	#4@48	#4@48	#4@48
	10	#4@36; #5@48	#4@48	#4@48
40	8	#4@48	#4@48	#4@48
	9	#4@36; #5@48	#4@36; #5@48	#4@48
	10	#4@24; #5@48	#4@24; #5@48	#4@24; #5@48
50	8	#4@36; #5@48	#4@36; #5@48	#4@48
	9	#4@24; #5@48	#4@24; #5@48	#4@24; #5@48
	10	Design Required	Design Required	Design Required
60	8	#4@24; #5@48	#4@24; #5@48	#4@36; #5@48
	9	#4@24; #5@36	#4@24; #5@36	#4@24; #5@36
	10	Design Required	Design Required	Design Required
70	8	#4@24; #5@36	#4@24; #5@36	#4@24; #5@36
	9	Design Required	Design Required	Design Required
	10	Design Required	Design Required	Design Required
080	8	#4@12; #5@36	#4@24; #5@36	#4@24; #5@36
	9	Design Required	Design Required	Design Required
	10	Design Required	Design Required	Design Required

For SI: 1 inch = 25.4 mm, 1 foot = 304.8 mm, 1 mile per hour = 0.447 m/s; 1 pound per square inch = 6.895 kPa.

a. This table is based on reinforcing bars with a minimum yield strength of 40,000 psi and concrete with a minimum specified compressive strength of 2,500 psi. For Seismic Design Categories D₀, D₁ and D₂, reinforcing bars shall have a minimum yield strength of 60,000 psi. See Section R611.6.2.

b. Deflection criterion is $L/240$, where L is the height of the wall story in inches.

c. Interpolation shall not be permitted.

d. Increasing reinforcement spacing by 12 inches shall be permitted when reinforcing steel with a minimum yield strength of 60,000 psi is used. Reinforcement shall not be less than one #4 bar at 48 inches on center.

e. See Section R611.7.1.2 for limitations on maximum spacing of vertical reinforcement in Seismic Design Categories C, D₀, D₁ and D₂.

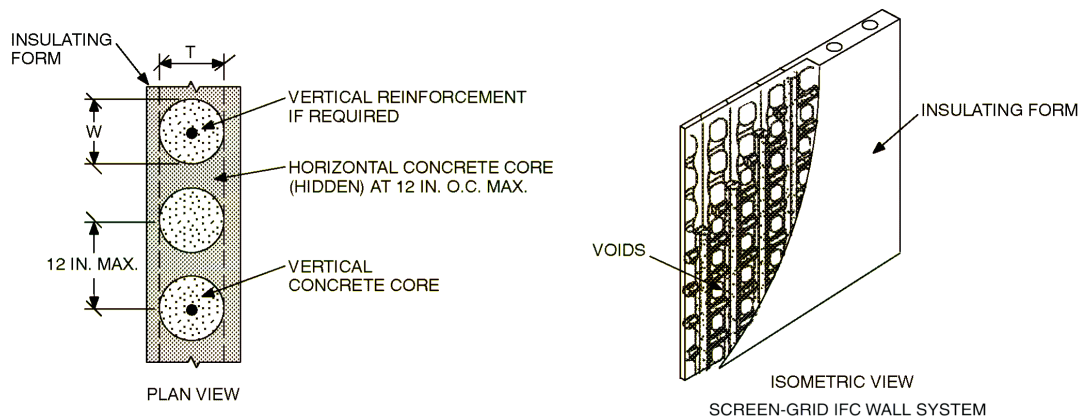

For SI: 1 inch = 25.4 mm.

FIGURE R611.5
SCREEN-GRID ICF WALL SYSTEM

R611.6.3 Insulation materials. Insulating concrete forms material shall meet the surface burning characteristics of Section R314.3. A thermal barrier shall be provided on the building interior in accordance with Section R314.4 or Section R702.3.4.

R611.7 Wall construction. Insulating concrete form walls shall be constructed in accordance with the provisions of this section and Figure R611.7(1).

R611.7.1 Reinforcement.

R611.7.1.1 Location. Vertical and horizontal wall reinforcement shall be placed within the middle third of the wall. Steel reinforcement shall have a minimum concrete cover in accordance with ACI 318.

Exception: Where insulated concrete forms are used and the form remains in place as cover for the concrete, the minimum concrete cover for the reinforcing steel is permitted to be reduced to $\frac{3}{4}$ inch (19 mm).

R611.7.1.2 Vertical steel. Above-grade concrete walls shall have reinforcement in accordance with Sections R611.3, R611.4, or R611.5 and R611.7.2. Where the design wind pressure exceeds 40 psf (1.92 kPa) in accordance with Table R611.3(1) or for townhouses in Seismic Design Category C and all buildings in Seismic Design Categories D₀, D₁ and D₂, vertical wall reinforcement in the top-most ICF story shall terminate with a 90-degree (1.57 rad) standard hook in accordance with Section R611.7.1.5. The free end of the hook shall be within 4 inches (102 mm) of the top of the ICF wall and shall be oriented parallel to the horizontal steel in the top of the wall.

For townhouses in Seismic Design Category C, the minimum vertical reinforcement shall be one No. 5 bar at 24 inches (610 mm) on center or one No. 4 at 16 inches (407 mm) on center. For all buildings in Seismic Design Categories D₀, D₁ and D₂, the minimum vertical reinforcement shall be one No. 5 bar at 18 inches (457 mm) on center or one No. 4 at 12 inches (305 mm) on center.

Above-grade ICF walls shall be supported on concrete foundations reinforced as required for the above-grade wall immediately above, or in accordance with Tables R404.4(1) through R404.4(5), whichever requires the greater amount of reinforcement.

Vertical reinforcement shall be continuous from the bottom of the foundation wall to the roof. Lap splices, if required, shall comply with Section R611.7.1.4. Where vertical reinforcement in the above-grade wall is not continuous with the foundation wall reinforcement, dowel bars with a size and spacing to match the vertical ICF wall reinforcement shall be embedded $40 d_b$ into the foundation wall and shall be lap spliced with the above-grade wall reinforcement. Alternatively, for No. 6 and larger bars, the portion of the bar embedded in the foundation wall shall be embedded 24 inches in the foundation wall and shall have a standard hook.

R611.7.1.3 Horizontal reinforcement. Concrete walls with a minimum thickness of 4 inches (102 mm) shall have a minimum of one continuous No. 4 horizontal reinforcing bar placed at 32 inches (812 mm) on center with

one bar within 12 inches (305 mm) of the top of the wall story. Concrete walls 5.5 inches (140 mm) thick or more shall have a minimum of one continuous No. 4 horizontal reinforcing bar placed at 48 inches (1219 mm) on center with one bar located within 12 inches (305 mm) of the top of the wall story.

For townhouses in Seismic Design Category C, the minimum horizontal reinforcement shall be one No. 5 bar at 24 inches (610 mm) on center or one No. 4 at 16 inches (407 mm) on center. For all buildings in Seismic Design Categories D₀, D₁ and D₂, the minimum horizontal reinforcement shall be one No. 5 bar at 18 inches (457 mm) on center or one No. 4 at 12 inches (305 mm) on center.

Horizontal reinforcement shall be continuous around building corners using corner bars or by bending the bars. In either case, the minimum lap splice shall be 24 inches (610 mm). For townhouses in Seismic Design Category C and for all buildings in Seismic Design Categories D₀, D₁ and D₂, each end of all horizontal reinforcement shall terminate with a standard hook or lap splice.

R611.7.1.4 Lap splices. Where lap splicing of vertical or horizontal reinforcing steel is necessary, the lap splice shall be in accordance with Figure R611.7.1.4 and a minimum of $40 d_b$, where d_b is the diameter of the smaller bar. The maximum distance between noncontact parallel bars at a lap splice shall not exceed $8 d_b$.

R611.7.1.5 Standard hook. Where the free end of a reinforcing bar is required to have a standard hook, the hook shall be a 180-degree bend plus $4 d_b$ extension but not less than $2\frac{1}{2}$ inches, or a 90-degree bend plus $12 d_b$ extension.

R611.7.2 Wall openings. Wall openings shall have a minimum of 8 inches (203 mm) of depth of concrete for flat and waffle-grid ICF walls and 12 inches (305 mm) for screen-grid walls over the length of the opening. When the depth of concrete above the opening is less than 12 inches for flat or waffle-grid walls, lintels in accordance with Section R611.7.3 shall be provided. Reinforcement around openings shall be provided in accordance with Table R611.7(1) and Figure R611.7(2). Reinforcement placed horizontally above or below an opening shall extend a minimum of 24 inches (610 mm) beyond the limits of the opening. Wall opening reinforcement shall be provided in addition to the reinforcement required by Sections R611.3, R611.4, R611.5 and R611.7.1. The perimeter of all wall openings shall be framed with a minimum 2-inch by 4-inch plate, anchored to the wall with $\frac{1}{2}$ -inch (13 mm) diameter anchor bolts spaced a maximum of 24 inches (610 mm) on center. The bolts shall be embedded into the concrete a minimum of 4 inches (102 mm) and have a minimum of $1\frac{1}{2}$ inches (38 mm) of concrete cover to the face of the wall.

Exception: The 2-inch by 4-inch plate is not required where the wall is formed to provide solid concrete around the perimeter of the opening with a minimum depth of 4 inches (102 mm) for the full thickness of the wall.

TABLE R611.7(1)
MINIMUM WALL OPENING REINFORCEMENT REQUIREMENTS IN ICF WALLS^a

WALL TYPE AND OPENING WIDTH (L) (feet)	MINIMUM HORIZONTAL OPENING REINFORCEMENT	MINIMUM VERTICAL OPENING REINFORCEMENT
Flat, Waffle-, and Screen-Grid: $L < 2$	None required	None required
Flat, Waffle-, and Screen-Grid: $L \geq 2$	Provide lintels in accordance with Section R611.7.3. Provide one No. 4 bar within 12 inches from the bottom of the opening. Top and bottom lintel reinforcement shall extend a minimum of 24 inches beyond the limits of the opening.	In locations with wind speeds less than or equal to 110 mph or in Seismic Design Categories A and B, provide one No. 4 bar for the full height of the wall story within 12 inches of each side of the opening. In locations with wind speeds greater than 110 mph, townhouses in Seismic Design Category C, or all buildings in Seismic Design Categories D ₀ , D ₁ and D ₂ , provide two No. 4 bars or one No. 5 bar for the full height of the wall story within 12 inches of each side of the opening.

For SI: 1 inch = 25.4 mm, 1 foot = 304.8 mm, 1 mile per hour = 0.447 m/s; 1 pound per square inch = 6.895 kPa.

a. This table is based on concrete with a minimum specified compressive strength of 2,500 psi, reinforcing steel with a minimum yield strength of 40,000 psi and an assumed equivalent rectangular cross section. This table is not intended to prohibit the use of ICF manufacturer's tables based on engineering analysis in accordance with ACI 318.

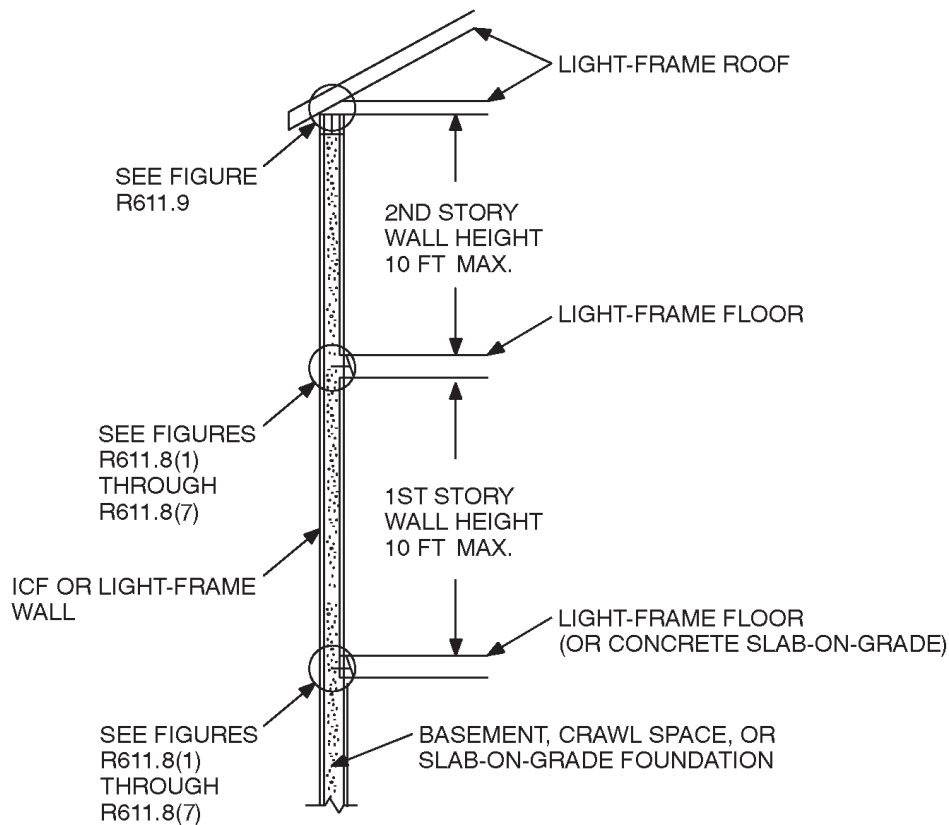

For SI: 1 foot = 304.8 mm.

NOTE: Section cut through flat wall or vertical core of waffle- or screen-grid walls.

FIGURE R611.7(1)
ICF WALL CONSTRUCTION

R611.7.3 Lintels.

R611.7.3.1 General requirements. Lintels shall be provided over all openings greater than or equal to 2 feet (610 mm) in width. Lintels for flat ICF walls shall be constructed in accordance with Figure R611.7(3) and Table R611.7(2) or R611.7(3). Lintels for waffle-grid ICF walls shall be constructed in accordance with Figure R611.7(4) or Figure R611.7(5) and Table R611.7(4) or R611.7(5). Lintels for screen-grid ICF walls shall be constructed in accordance with Figure R611.7(6) or Figure R611.7(7). Lintel construction in accordance with Figure R611.7(3) shall be permitted with waffle-grid and screen-grid ICF wall construction. Lintel depths are permitted to be increased by the height of the ICF wall located directly above the opening, provided that the lintel depth spans the entire length of the opening.

R611.7.3.2 Stirrups. Where required, No. 3 stirrups shall be installed in flat, waffle-grid and screen-grid wall lintels in accordance with the following:

1. For flat walls the stirrups shall be spaced at a maximum spacing of $d/2$ where d equals the depth of the lintel (D) minus the bottom cover of concrete as shown in Figure R611.7(3). Stirrups shall not be required in the middle portion of the span (A) per Figure R611.7(2), for flat walls for a length not to exceed the values shown in parenthesis in Tables R611.7(2) and R611.7(3) or for spans in accordance with Table R611.7(8).
2. For waffle-grid walls a minimum of two No. 3 stirrups shall be placed in each vertical core of waffle-grid lintels. Stirrups shall not be required in the middle portion of the span (A) per Figure R611.7(2), for waffle-grid walls for a length not to exceed the values shown in parenthesis in Tables R611.7(4) and R611.7(5) or for spans in accordance with Table R611.7(8).
3. For screen-grid walls one No. 3 stirrup shall be placed in each vertical core of screen-grid lintels.

Exception: Stirrups are not required in screen-grid lintels meeting the following requirements:

1. Lintel Depth (D) = 12 inches (305 mm) - spans less than or equal 3 feet 7 inches.
2. Lintel Depth (D) = 24 inches (610 mm) - spans less than or equal 4 feet 4 inches.

R611.7.3.3 Horizontal reinforcement. One No. 4 horizontal bar shall be provided in the top of the lintel. Horizontal reinforcement placed within 12 inches (305 mm) of the top of the wall in accordance with Section R611.7.1.3 shall be permitted to serve as the top or bottom reinforcement in the lintel provided the reinforcement meets the location requirements in Figure R611.7(2), R611.7(3), R611.7(4), R611.7(5),

R611.7(6), or R611.7(7), and the size requirements in Tables R611.7(2), R611.7(3), R611.7(4), R611.7(5), R611.7(6), R611.7(7), or R611.7(8).

R611.7.3.4 Load-bearing walls. Lintels in flat ICF load-bearing walls shall comply with Table R611.7(2), Table RR611.7(3) or Table R611.7(8). Lintels in waffle-grid ICF load-bearing walls shall comply with Table R611.7(4), Table R611.7(5) or Table R611.7(8). Lintels in screen-grid ICF load-bearing walls shall comply with Table R611.7(6) or Table R611.7(7).

Where spans larger than those permitted in Table R611.7(2), Table R611.7(3), Table R611.7(4), Table R611.7(5), R611.7(6), R611.7(7) or R611.7(8) are required, the lintels shall comply with Table R611.7 (9).

R611.7.3.5 Nonload-bearing walls. Lintels in nonload-bearing flat, waffle-grid and screen-grid ICF walls shall comply with Table R611.7 (10). Stirrups are not required.

R611.7.4 Minimum length of wall without openings. The wind velocity pressures of Table R611.7.4 shall be used to determine the minimum amount of solid wall length in accordance with Tables R611.7(9A) through R611.7(10B) and Figure R611.7.4. Table R611.7(11) shall be used to determine the minimum amount of solid wall length for townhouses in Seismic Design Category C, and all buildings in Seismic Design Categories D_0 , D_1 and D_2 for all types of ICF walls. The greater amount of solid wall length required by wind loading or seismic loading shall apply. The minimum percentage of solid wall length shall include only those solid wall segments that are a minimum of 24 inches (610 mm) in length. The maximum distance between wall segments included in determining solid wall length shall not exceed 18 feet (5486 mm). A minimum length of 24 inches (610 mm) of solid wall segment, extending the full height of each wall story, shall occur at all interior and exterior corners of exterior walls.

R611.8 ICF wall-to-floor connections.

R611.8.1 Top bearing. Floors bearing on the top of ICF foundation walls in accordance with Figure R611.8(1) shall have the wood sill plate anchored to the ICF wall with minimum $1/2$ -inch (13 mm) diameter bolts embedded a minimum of 7 inches (178 mm) and placed at a maximum spacing of 6 feet (1829 mm) on center and not more than 12 inches (305 mm) from corners. Anchor bolts for waffle-grid and screen-grid walls shall be located in the cores. In conditions where wind speeds are in excess of 90 miles per hour (40 m/s), the $1/2$ -inch (13 mm) diameter anchor bolts shall be placed at a maximum spacing of 4 feet (1219 mm) on center. Bolts shall extend a minimum of 7 inches (178 mm) into concrete. Sill plates shall be protected against decay where required by Section R319. Cold-formed steel framing systems shall be anchored to the concrete in accordance with Section R505.3.1 or Section R603.3.1.

TABLE R611.7(2)
MAXIMUM ALLOWABLE CLEAR SPANS FOR ICF LINTELS FOR FLAT LOAD-BEARING WALLS^{a, b, c, d, f}
NO. 4 BOTTOM BAR SIZE

MINIMUM LINTEL THICKNESS, T (inches)	LINTEL DEPTH, D (inches)	MAXIMUM CLEAR SPAN, (feet-inches) (Number is Middle of Span, A) ^e					
		Supporting Roof Only		Supporting Light-Framed 2nd Story and Roof		Supporting ICF Second Story and Roof	
		Ground Snow Load					
		30 psf	70 psf	30 psf	70 psf	30 psf	70 psf
3.5	8	4-9 (1-2)	4-2 (0-9)	3-10 (0-8)	3-4 (0-6)	3-5 (0-6)	3-1 (0-5)
	12	6-8 (1-11)	5-5 (1-3)	5-0 (1-1)	4-5 (0-10)	4-6 (0-10)	4-0 (0-8)
	16	7-11 (2-9)	6-5 (1-9)	6-0 (1-6)	5-3 (1-2)	5-4 (1-2)	4-10 (1-0)
	20	8-11 (3-5)	7-4 (2-3)	6-9 (1-11)	6-0 (1-6)	6-1 (1-7)	5-6 (1-3)
	24	9-10 (4-1)	8-1 (2-9)	7-6 (2-4)	6-7 (1-10)	6-9 (1-11)	6-1 (1-6)
5.5	8	5-2 (1-10)	4-2 (1-2)	3-10 (1-0)	3-5 (0-9)	3-5 (0-10)	3-1 (0-8)
	12	6-8 (3-0)	5-5 (2-0)	5-0 (1-9)	4-5 (1-4)	4-6 (1-4)	4-1 (1-1)
	16	7-10 (4-1)	6-5 (2-9)	6-0 (2-5)	5-3 (1-10)	5-4 (1-11)	4-10 (1-7)
	20	8-10 (5-3)	7-3 (3-6)	6-9 (3-1)	6-0 (2-4)	6-1 (2-5)	5-6 (2-0)
	24	9-8 (6-3)	8-0 (4-3)	7-5 (3-8)	6-7 (2-11)	6-8 (3-0)	6-0 (2-5)
7.5	8	5-2 (2-6)	4-2 (1-8)	3-11 (1-5)	3-5 (1-1)	3-6 (1-1)	3-2 (0-11)
	12	6-7 (4-0)	5-5 (2-8)	5-0 (2-4)	4-5 (1-10)	4-6 (1-10)	4-1 (1-6)
	16	7-9 (5-5)	6-5 (3-8)	5-11 (3-3)	5-3 (2-6)	5-4 (2-7)	4-10 (2-2)
	20	8-8 (6-10)	7-2 (4-8)	6-8 (4-2)	5-11 (3-3)	6-0 (3-4)	5-5 (2-9)
	24	9-6 (8-2)	7-11 (5-8)	7-4 (5-1)	6-6 (3-11)	6-7 (4-1)	6-0 (3-4)
9.5	8	5-2 (3-1)	4-2 (2-1)	3-11 (1-9)	3-5 (1-5)	3-6 (1-5)	3-2 (1-2)
	12	6-7 (5-0)	5-5 (3-4)	5-0 (3-0)	4-5 (2-4)	4-6 (2-5)	4-1 (1-11)
	16	7-8 (6-9)	6-4 (4-7)	5-11 (4-2)	5-3 (3-3)	5-4 (3-4)	4-10 (2-8)

For SI: 1 inch = 25.4 mm, 1 foot = 304.8 mm, 1 pound per square inch = 6.895kPa, 1 pound per square foot = 0.0479 kPa.

- a. This table is based on concrete with a minimum specified compressive strength of 2,500 psi, reinforcing steel with a minimum yield strength of 40,000 psi and an assumed equivalent rectangular cross section. When reinforcement with a minimum yield strength of 60,000 psi is used, the span lengths in the shaded cells shall be increased by 1.2 times the table values.
- b. This table is not intended to prohibit the use of ICF manufacturer's tables based on engineering analysis in accordance with ACI 318.
- c. Deflection criterion: $L/240$.
- d. Design load assumptions:
 Floor dead load is 10 psf Attic live load is 20 psf
 Floor live load is 30 psf Roof dead load is 15 psf
 Building width is 32 feet ICF wall dead load is 69 psf
 Light-framed wall dead load is 10 psf
- e. No. 3 stirrups are required at $d/2$ spacing except no stirrups are required for the distance, (A), shown in the middle portion of the span in accordance with Figure R611.7(2) and Section R611.7.3.2.
- f. Interpolation is permitted between ground snow loads and between lintel depths.

TABLE R611.7(3)
MAXIMUM ALLOWABLE CLEAR SPANS FOR ICF LINTELS FOR FLAT LOAD-BEARING WALLS^{a, b, c, d, f}
NO. 5 BOTTOM BAR SIZE

MINIMUM LINTEL THICKNESS, T (inches)	LINTEL DEPTH, D (inches)	MAXIMUM CLEAR SPAN, (feet-inches) (Number is Middle of Span, A) ^e					
		Supporting Roof		Supporting Light-Framed 2nd Story and Roof		Supporting ICF Second Story and Roof	
		Ground Snow Load					
		30 psf	70 psf	30 psf	70 psf	30 psf	70 psf
3.5	8	4-9 (1-2)	4-2 (0-9)	3-11 (0-8)	3-7 (0-6)	3-7 (0-6)	3-5 (0-5)
	12	7-2 (1-11)	6-3 (1-3)	5-11 (1-1)	5-5 (0-10)	5-5 (0-10)	5-0 (0-8)
	16	9-6 (2-9)	8-0 (1-9)	7-4 (1-6)	6-6 (1-2)	6-7 (1-2)	5-11 (1-0)
	20	11-1 (3-5)	9-1 (2-3)	8-4 (1-11)	7-5 (1-6)	7-6 (1-7)	6-9 (1-3)
	24	12-2 (4-1)	10-0 (2-9)	9-3 (2-4)	8-2 (1-10)	8-4 (1-11)	7-6 (1-6)
5.5	8	5-6 (1-10)	4-10 (1-2)	4-7 (1-0)	4-2 (0-9)	4-2 (0-10)	3-10 (0-8)
	12	8-3 (3-0)	6-9 (2-0)	6-3 (1-9)	5-6 (1-4)	5-7 (1-4)	5-0 (1-1)
	16	9-9 (4-1)	8-0 (2-9)	7-5 (2-5)	6-6 (1-10)	6-7 (1-11)	6-0 (1-7)
	20	10-11 (5-3)	9-0 (3-6)	8-4 (3-1)	7-5 (2-4)	7-6 (2-5)	6-9 (2-0)
	24	12-0 (6-3)	9-11 (4-3)	9-3 (3-8)	8-2 (2-11)	8-3 (3-0)	7-6 (2-5)
7.5	8	6-1 (2-6)	5-2 (1-8)	4-9 (1-5)	4-3 (1-1)	4-3 (1-1)	3-10 (0-11)
	12	8-2 (4-0)	6-9 (2-8)	6-3 (2-4)	5-6 (1-10)	5-7 (1-10)	5-0 (1-6)
	16	9-7 (5-5)	7-11 (3-8)	7-4 (3-3)	6-6 (2-6)	6-7 (2-7)	6-0 (2-2)
	20	10-10 (6-10)	8-11 (4-8)	8-4 (4-2)	7-4 (3-3)	7-6 (3-4)	6-9 (2-9)
	24	11-10 (8-2)	9-10 (5-8)	9-2 (5-1)	8-1 (3-11)	8-3 (4-1)	7-5 (3-4)
9.5	8	6-4 (3-1)	5-2 (2-1)	4-10 (1-9)	4-3 (1-5)	4-4 (1-5)	3-11 (1-2)
	12	8-2 (5-0)	6-8 (3-4)	6-2 (3-0)	5-6 (2-4)	5-7 (2-5)	5-0 (1-11)
	16	9-6 (6-9)	7-11 (4-7)	7-4 (4-2)	6-6 (3-3)	6-7 (3-4)	5-11 (2-8)
	20	10-8 (8-4)	8-10 (5-10)	8-3 (5-4)	7-4 (4-2)	7-5 (4-3)	6-9 (3-6)
	24	11-7 (10-0)	9-9 (6-11)	9-0 (6-5)	8-1 (5-0)	8-2 (5-2)	7-5 (4-3)

For SI: 1 inch = 25.4 mm, 1 foot = 304.8 mm, 1 pound per square inch = 6.895 kPa, 1 pound per square foot = 0.0479 kPa.

a. This table is based on concrete with a minimum specified compressive strength of 2,500 psi, reinforcing steel with a minimum yield strength of 40,000 psi and an assumed equivalent rectangular cross section. When reinforcement with a minimum yield strength of 60,000 psi is used the span lengths in the shaded cells shall be increased by 1.2 times the table values.

b. This table is not intended to prohibit the use of ICF manufacturer's tables based on engineering analysis in accordance with ACI 318.

c. Deflection criterion: $L/240$.

d. Design load assumptions:

Floor dead load is 10 psf	Attic live load is 20 psf
Floor live load is 30 psf	Roof dead load is 15 psf
Building width is 32 feet	ICF wall dead load is 69 psf
Light-framed wall dead load is 10 psf	

e. No. 3 stirrups are required at $d/2$ spacing except no stirrups are required for the distance, (A), shown in the middle portion of the span in accordance with Figure R611.7(2) and Section R611.7.3.2.

f. Interpolation is permitted between ground snow loads and between lintel depths.

TABLE R611.7(4)
MAXIMUM ALLOWABLE CLEAR SPANS FOR WAFFLE-GRID ICF WALL LINTELS^{a, b, c, d, f}
NO. 4 BOTTOM BAR SIZE

NOMINAL LINTEL THICKNESS T ^{g, h} (inches)	LINTEL DEPTH D (inches)	MAXIMUM CLEAR SPAN (feet-inches) (Number is Middle of Span, A) ^e					
		Supporting Roof		Supporting Light-Framed 2nd Story and Roof		Supporting ICF Second Story and Roof	
		Ground Snow Load					
		30 psf	70 psf	30 psf	70 psf	30 psf	70 psf
6	8	5-2 (0-10)	4-2 (0-7)	3-10 (0-6)	3-5 (0-4)	3-6 (0-5)	3-2 (0-4)
	12	6-8 (1-5)	5-5 (0-11)	5-0 (0-9)	4-5 (0-7)	4-7 (0-8)	4-2 (0-6)
	16	7-11 (1-11)	6-6 (1-4)	6-0 (1-1)	5-3 (0-10)	5-6 (0-11)	4-11 (0-9)
	20	8-11 (2-6)	7-4 (1-8)	6-9 (1-5)	6-0 (1-1)	6-3 (1-2)	5-7 (0-11)
	24	9-10 (3-0)	8-1 (2-0)	7-6 (1-9)	6-7 (1-4)	6-10 (1-5)	6-2 (1-2)
8	8	5-2 (0-10)	4-3 (0-7)	3-11 (0-6)	3-5 (0-4)	3-7 (0-5)	3-2 (0-4)
	12	6-8 (1-5)	5-5 (0-11)	5-1 (0-9)	4-5 (0-7)	4-8 (0-8)	4-2 (0-6)
	16	7-10 (1-11)	6-5 (1-4)	6-0 (1-1)	5-3 (0-10)	5-6 (0-11)	4-11 (0-9)
	20	8-10 (2-6)	7-3 (1-8)	6-9 (1-5)	6-0 (1-1)	6-2 (1-2)	5-7 (0-11)
	24	9-8 (3-0)	8-0 (2-0)	7-5 (1-9)	6-7 (1-4)	6-10 (1-5)	6-2 (1-2)

For SI: 1 inch = 25.4 mm, 1 foot = 304.8 mm, 1 psi = 6.895 kPa, 1 psf = 0.0479 kPa.

- a. This table is based on concrete with a minimum specified compressive strength of 2,500 psi, reinforcing steel with a minimum yield strength of 40,000 psi and an assumed equivalent rectangular cross section. When reinforcement with a minimum yield strength of 60,000 psi is used the span lengths in the shaded cells shall be increased by 1.2 times the table values.
- b. This table is not intended to prohibit the use of ICF manufacturer's tables based on engineering analysis in accordance with ACI 318.
- c. Deflection criterion: $L/240$.
- d. Design load assumptions:
 - Floor dead load is 10 psf
 - Floor live load is 30 psf
 - Building width is 32 feet
 - Light-framed wall dead load is 10 psf
 - Attic live load is 20 psf
 - Roof dead load is 15 psf
 - ICF wall dead load is 55 psf
- e. No. 3 stirrups are required at $d/2$ spacing except no stirrups are required for the distance, (A), shown in the middle portion of the span in accordance with Figure R611.7(2) and Section R611.7.3.2.
- f. Interpolation is permitted between ground snow loads and between lintel depths.
- g. For actual wall lintel width, refer to Table R611.2.
- h. Lintel width corresponds to the nominal waffle-grid ICF wall thickness with a minimum thickness of 2 inches.

TABLE R611.7(5)
MAXIMUM ALLOWABLE CLEAR SPANS FOR WAFFLE-GRID ICF WALL LINTELS^{a, b, c, d, f}
NO. 5 BOTTOM BAR SIZE

NOMINAL LINTEL THICKNESS, T ^{g, h} (inches)	LINTEL DEPTH D (inches)	MAXIMUM CLEAR SPAN (feet-inches) (Number is Middle of Span, A) ^e					
		Supporting Roof		Supporting Light-Framed 2nd Story and Roof		Supporting ICF Second Story and Roof	
		Ground Snow Load					
		30 psf	70 psf	30 psf	70 psf	30 psf	70 psf
6	8	5-4 (0-10)	4-8 (0-7)	4-5 (0-6)	4-1 (0-4)	4-5 (0-5)	3-10 (0-4)
	12	8-0 (1-5)	6-9 (0-11)	6-3 (0-9)	5-6 (0-7)	6-3 (0-8)	5-1 (0-6)
	16	9-9 (1-11)	8-0 (1-4)	7-5 (1-1)	6-6 (0-10)	7-5 (0-11)	6-1 (0-9)
	20	11-0 (2-6)	9-1 (1-8)	8-5 (1-5)	7-5 (1-1)	8-5 (1-2)	6-11 (0-11)
	24	12-2 (3-0)	10-0 (2-0)	9-3 (1-9)	8-2 (1-4)	9-3 (1-5)	7-8 (1-2)
8	8	6-0 (0-10)	5-2 (0-7)	4-9 (0-6)	4-3 (0-4)	4-9 (0-5)	3-11 (0-4)
	12	8-3 (1-5)	6-9 (0-11)	6-3 (0-9)	5-6 (0-7)	6-3 (0-8)	5-2 (0-6)
	16	9-9 (1-11)	8-0 (1-4)	7-5 (1-1)	6-6 (0-10)	7-5 (0-11)	6-1 (0-9)
	20	10-11 (2-6)	9-0 (1-8)	8-4 (1-5)	7-5 (1-1)	8-4 (1-2)	6-11 (0-11)
	24	12-0 (3-0)	9-11 (2-0)	9-2 (1-9)	8-2 (1-4)	9-2 (1-5)	7-8 (1-2)

For SI: 1 inch = 25.4 mm, 1 foot = 304.8 mm, 1 psi = 6.895 kPa, 1 psf = 0.0479 kPa.

- a. This table is based on concrete with a minimum specified compressive strength of 2,500 psi, reinforcing steel with a minimum yield strength of 40,000 psi and an assumed equivalent rectangular cross section. When reinforcement with a minimum yield strength of 60,000 psi is used the span lengths in the shaded cells shall be increased by 1.2 times the table values.
- b. This table is not intended to prohibit the use of ICF manufacturer's tables based on engineering analysis in accordance with ACI 318.
- c. Deflection criterion: $L/240$.
- d. Design load assumptions:
 Floor dead load is 10 psf Attic live load is 20 psf
 Floor live load is 30 psf Roof dead load is 15 psf
 Building width is 32 feet ICF wall dead load is 53 psf
 Light-framed wall dead load is 10 psf
- e. No. 3 stirrups are required at $d/2$ spacing except no stirrups are required for the distance, (A), shown in the middle portion of the span in accordance with Figure R611.7(2) and Section R611.7.3.2.
- f. Interpolation is permitted between ground snow loads and between lintel depths.
- g. For actual wall lintel width, refer to Table R611.2.
- h. Lintel width corresponds to the nominal waffle-grid ICF wall thickness with a minimum thickness of 2 inches.

TABLE R611.7(6)
MAXIMUM ALLOWABLE CLEAR SPANS FOR SCREEN-GRID ICF LINTELS IN LOAD-BEARING WALLS^{a, b, c, d, e, f, g}
NO. 4 BOTTOM BAR SIZE

MINIMUM LINTEL THICKNESS, T (inches) ^{h, i}	MINIMUM LINTEL DEPTH, D (inches)	MAXIMUM CLEAR SPAN (feet-inches)					
		Supporting Roof		Supporting Light-Framed Second Story and Roof		Supporting ICF Second Story and Roof	
		Maximum Ground Snow Load (psf)					
		30	70	30	70	30	70
6	12	3-7	2-10	2-5	2-0	2-0	NA
	24	9-10	8-1	7-6	6-7	6-11	6-2

For SI: 1 inch = 25.4 mm, 1 foot = 304.8 mm, 1 psi = 6.895 kPa, 1 psf = 0.0479 kPa.

- a. This table is based on concrete with a minimum specified compressive strength of 2,500 psi, reinforcing steel with a minimum yield strength of 40,000 psi and an assumed equivalent rectangular cross section. When reinforcement with a minimum yield strength of 60,000 psi is used the span lengths in the shaded cells shall be increased by 1.2 times the table values.
- b. This table is not intended to prohibit the use of ICF manufacturer’s tables based on engineering analysis in accordance with ACI 318.
- c. Deflection criterion: $L/240$.
- d. Design load assumptions:
 - Floor dead load is 10 psf
 - Floor live load is 30 psf
 - Maximum floor clear span is 32 ft
 - Light-frame wall dead load is 10 psf
 - Attic live load is 20 psf
 - Roof dead load is 15 psf
 - ICF wall dead load is 53 psf
- e. Stirrup requirements:
 - Stirrups are not required for lintels 12 inches deep.
 - One No. 3 stirrup is required in each vertical core for lintels 24 inches deep.
- f. Interpolation is permitted between ground snow loads.
- g. Flat ICF lintels may be used in lieu of screen-grid lintels.
- h. For actual wall lintel width, refer to Table R611.2.
- i. Lintel width corresponds to the nominal screen-grid ICF wall thickness.

TABLE R611.7(7)
MAXIMUM ALLOWABLE CLEAR SPANS FOR SCREEN-GRID ICF LINTELS IN LOAD-BEARING WALLS^{a, b, c, d, e, f, g}
NO. 5 BOTTOM BAR SIZE

MINIMUM LINTEL THICKNESS, T (inches) ^{h, i}	MINIMUM LINTEL DEPTH, D (inches)	MAXIMUM CLEAR SPAN (feet-inches)					
		Supporting Roof		Supporting Light-Framed Second Story and Roof		Supporting ICF Second Story and Roof	
		Maximum Ground Snow Load (psf)					
		30	70	30	70	30	70
6	12	3-7	2-10	2-5	2-0	2-0	NA
	24	12-3	10-0	9-3	8-3	8-7	7-8

For SI: 1 inch = 25.4 mm, 1 foot = 304.8 mm, 1 pound per square inch = 6.895 kPa, 1 pound per square foot = 0.0479 kPa.

- a. This table is based on concrete with a minimum specified compressive strength of 2,500 psi, reinforcing steel with a minimum yield strength of 40,000 psi and an assumed equivalent rectangular cross section. When reinforcement with a minimum yield strength of 60,000 psi is used the span lengths in the shaded cells shall be increased by 1.2 times the table values.
- b. This table is not intended to prohibit the use of ICF manufacturer’s tables based on engineering analysis in accordance with ACI 318.
- c. Deflection criterion: $L/240$.
- d. Design load assumptions:
 - Floor dead load is 10 psf
 - Floor live load is 30 psf
 - Maximum floor clear span is 32 ft
 - Light-frame wall dead load is 10 psf
 - Attic live load is 20 psf
 - Roof dead load is 15 psf
 - ICF wall dead load is 53 psf
- e. Stirrup requirements:
 - Stirrups are not required for lintels 12 inches deep.
 - One No. 3 stirrup is required in each vertical core for lintels 24 inches deep.
- f. Interpolation is permitted between ground snow loads.
- g. Flat ICF lintels may be used in lieu of screen-grid lintels.
- h. For actual wall lintel width, refer to Table R611.2.
- i. Lintel width corresponds to the nominal screen-grid ICF wall thickness.

TABLE R611.7(8)
MAXIMUM ALLOWABLE CLEAR SPANS FOR ICF LINTELS WITHOUT STIRRUPS IN LOAD-BEARING WALLS^{a, b, c, d, e, f, g, h}
(NO. 4 OR NO. 5) BOTTOM BAR SIZE

MINIMUM LINTEL THICKNESS, T (inches)	MINIMUM LINTEL DEPTH, D (inches)	MAXIMUM CLEAR SPAN (feet-inches)					
		Supporting Roof Only		Supporting Light-Framed Second Story and Roof		Supporting ICF Second Story and Roof	
		MAXIMUM GROUND SNOW LOAD (psf)					
		30	70	30	70	30	70
Flat ICF Lintel							
3.5	8	2-6	2-6	2-6	2-4	2-5	2-2
	12	4-2	4-2	4-1	3-10	3-10	3-7
	16	4-11	4-8	4-6	4-2	4-2	3-11
	20	6-3	5-3	4-11	4-6	4-6	4-3
	24	7-7	6-4	6-0	5-6	5-6	5-2
5.5	8	2-10	2-6	2-6	2-5	2-6	2-2
	12	4-8	4-4	4-3	3-11	3-10	3-7
	16	6-5	5-1	4-8	4-2	4-3	3-11
	20	8-2	6-6	6-0	5-4	5-5	5-0
	24	9-8	7-11	7-4	6-6	6-7	6-1
7.5	8	3-6	2-8	2-7	2-5	2-5	2-2
	12	5-9	4-5	4-4	4-0	3-10	3-7
	16	7-9	6-1	5-7	4-10	4-11	4-5
	20	8-8	7-2	6-8	5-11	6-0	5-5
	24	9-6	7-11	7-4	6-6	6-7	6-0
9.5	8	4-2	3-1	2-9	2-5	2-5	2-2
	12	6-7	5-1	4-7	3-11	4-0	3-7
	16	7-10	6-4	5-11	5-3	5-4	4-10
	20	8-7	7-2	6-8	5-11	6-0	5-5
	24	9-4	7-10	7-3	6-6	6-7	6-0
Waffle-Grid ICF Lintel							
6 or 8	8	2-6	2-6	2-6	2-4	2-4	2-2
	12	4-2	4-2	4-1	3-8	3-9	3-7
	16	5-9	5-8	5-7	5-1	5-2	4-8
	20	7-6	7-4	6-9	6-0	6-3	5-7
	24	9-2	8-1	7-6	6-7	6-10	6-2

For SI: 1 inch = 25.4 mm; 1 foot = 304.8 mm; 1 pound per square foot = 0.0479 kPa; 1 pound per square inch = 6.895 kPa.

- a. Table values are based on tensile reinforcement with a minimum yield strength of 40,000 psi (276 MPa), concrete with a minimum specified compressive strength of 2,500 psi, and a building width (clear span) of 32 feet.
- b. Spans located in shaded cells shall be permitted to be multiplied by 1.05 when concrete with a minimum compressive strength of 3,000 psi is used or by 1.1 when concrete with a minimum compressive strength of 4,000 psi is used.
- c. Deflection criterion is $L/240$, where L is the clear span of the lintel in inches.
- d. Linear interpolation shall be permitted between ground snow loads and between lintel depths.
- e. Lintel depth, D , shall be permitted to include the available height of ICF wall located directly above the lintel, provided that the increased lintel depth spans the entire length of the opening.
- f. Spans shall be permitted to be multiplied by 1.05 for a building width (clear span) of 28 feet.
- g. Spans shall be permitted to be multiplied by 1.1 for a building width (clear span) of 24 feet or less.
- h. ICF wall dead load is 69 psf.

TABLE R611.7(9)
MINIMUM BOTTOM BAR ICF LINTEL REINFORCEMENT FOR LARGE CLEAR SPANS IN LOAD-BEARING WALLS^{a, b, c, d, e, f, h}

MINIMUM LINTEL THICKNESS, T ^g (inches)	MINIMUM LINTEL DEPTH, D (inches)	MINIMUM BOTTOM LINTEL REINFORCEMENT					
		Supporting Light-Frame Roof Only		Supporting Light-Framed Second Story and Roof		Supporting ICF Second Story and Light-Frame Roof	
		Maximum Ground Snow Load (psf)					
		30	70	30	70	30	70
Flat ICF Lintel, 12 feet-3 inches Maximum Clear Span							
3.5	24	1 #5	1 #7	D/R	D/R	D/R	D/R
5.5	20	1 #6	1 #7	D/R	D/R	D/R	D/R
	24	1 #5	1 #7	1 #7	1 #8	1 #8	D/R
7.5	16	1 #7; 2 #5	D/R	D/R	D/R	D/R	D/R
	20	1 #6; 2 #4	1 #7; 2 #5	1 #8; 2 #6	D/R	D/R	D/R
	24	1 #6; 2 #4	1 #7; 2 #5	1 #7; 2 #5	1 #8; 2 #6	1 #8; 2 #6	1 #8; 2 #6
9.5	16	1 #7; 2 #5	D/R	D/R	D/R	D/R	D/R
	20	1 #6; 2 #4	1 #7; 2 #5	1 #8; 2 #6	1 #8; 2 #6	1 #8; 2 #6	1 #9; 2 #6
	24	1 #6; 2 #4	1 #7; 2 #5	1 #7; 2 #5	1 #7; 2 #6	1 #8; 2 #6	1 #9; 2 #6
Flat ICF Lintel, 16 feet-3 inches Maximum Clear Span							
5.5	24	1 #7	D/R	D/R	D/R	D/R	D/R
7.5	24	1 #7; 2 #5	D/R	D/R	D/R	D/R	D/R
9.5	24	1 #7; 2 #5	1 #9; 2 #6	1 #9; 2 #6	D/R	D/R	D/R
Waffle-Grid ICF Lintel, 12 feet-3 inches Maximum Clear Span							
6	20	1 #6	D/R	D/R	D/R	D/R	D/R
	24	1 #5	1 #7; 2 #5	1 #7; 2 #5	1 #8; 2 #6	1 #8; 2 #6	D/R
8	16	1 #7; 2 #5	D/R	D/R	D/R	D/R	D/R
	20	1 #6; 2 #4	1 #7; 2 #5	1 #8; 2 #6	D/R	D/R	D/R
	24	1 #5	1 #7; 2 #5	1 #7; 2 #5	1 #8; 2 #6	1 #8; 2 #6	1 #8; 2 #6
Screen-Grid ICF Lintel, 12 feet-3 inches Maximum Clear Span							
6	24	1 #5	1 #7	D/R	D/R	D/R	D/R

For SI: 1 inch = 25.4 mm, 1 foot = 304.8 mm, 1 psi = 6.895 kPa, 1 psf = 0.0479 kPa.

- a. This table is based on concrete with a minimum specified compressive strength of 2,500 psi, reinforcing steel with a minimum yield strength of 40,000 psi and an assumed equivalent rectangular cross section. When reinforcement with a minimum yield strength of 60,000 psi is used the span lengths in the shaded cells shall be increased by 1.2 times the table values.
- b. This table is not intended to prohibit the use of ICF manufacturers tables based on engineering analysis in accordance with ACI 318.
- c. D/R indicates design is required.
- d. Deflection criterion: $L/240$.
- e. Interpolation is permitted between ground snow loads and between lintel depths.
- f. No. 3 stirrups are required a maximum d/2 spacing for spans greater than 4 feet.
- g. Actual thickness is shown for flat lintels; nominal thickness is given for waffle-grid and screen-grid lintels. Lintel thickness corresponds to the nominal waffle-grid and screen-grid ICF wall thickness. Refer to Table R611.2 for actual wall thickness.
- h. ICF wall dead load varies based on wall thickness using 150 pcf concrete density.

WALL CONSTRUCTION

TABLE R611.7(9A)
MINIMUM SOLID END WALL LENGTH REQUIREMENTS FOR FLAT ICF WALLS (WIND PERPENDICULAR TO RIDGE)^{a, b, c}

WALL CATEGORY	BUILDING SIDE WALL LENGTH, L (feet)	Roof Slope	WIND VELOCITY PRESSURE FROM TABLE R611.7.4 (psf)								
			20	25	30	35	40	45	50	60	
			Minimum Solid Wall Length on Building End Wall (feet)								
One-Story or Top Story of Two-Story	16	≤ 1:12	4.00	4.00	4.00	4.00	4.00	4.00	4.00	4.00	4.00
		5:12	4.00	4.00	4.00	4.00	4.00	4.00	4.00	4.25	4.50
		7:12 ^d	4.00	4.25	4.25	4.50	4.75	4.75	4.75	5.00	5.50
		12:12 ^d	4.25	4.50	4.75	5.00	5.25	5.50	5.50	5.75	6.25
	24	≤ 1:12	4.00	4.00	4.00	4.00	4.00	4.00	4.00	4.25	4.50
		5:12	4.00	4.00	4.00	4.25	4.25	4.50	4.50	4.50	4.75
		7:12 ^d	4.25	4.50	4.75	5.00	5.25	5.50	5.50	5.75	6.25
		12:12 ^d	4.75	5.00	5.25	5.75	6.00	6.50	6.50	6.75	7.50
	32	≤ 1:12	4.00	4.00	4.00	4.00	4.25	4.25	4.25	4.50	4.75
		5:12	4.00	4.00	4.25	4.50	4.50	4.75	5.00	5.00	5.25
		7:12 ^d	4.50	5.00	5.25	5.50	6.00	6.25	6.50	6.50	7.25
		12:12 ^d	5.00	5.50	6.00	6.50	7.00	7.25	7.25	7.75	8.75
	40	≤ 1:12	4.00	4.00	4.25	4.25	4.50	4.50	4.50	4.75	5.00
		5:12	4.00	4.25	4.50	4.75	4.75	5.00	5.00	5.25	5.50
		7:12 ^d	4.75	5.25	5.75	6.00	6.50	7.00	7.00	7.25	8.00
		12:12 ^d	5.50	6.00	6.50	7.25	7.75	8.25	8.25	8.75	10.0
	50	≤ 1:12	4.00	4.25	4.25	4.50	4.75	4.75	4.75	5.00	5.50
		5:12	4.25	4.50	4.75	5.00	5.25	5.50	5.50	5.75	6.00
		7:12 ^d	5.25	5.75	6.25	6.75	7.25	7.75	7.75	8.25	9.25
		12:12 ^d	6.00	6.75	7.50	8.00	8.75	9.50	9.50	10.25	11.5
	60	≤ 1:12	4.00	4.25	4.50	4.75	5.00	5.25	5.25	5.25	5.75
		5:12	4.50	4.75	5.00	5.25	5.50	5.75	6.00	6.00	6.75
		7:12 ^d	5.50	6.25	6.75	7.50	8.00	8.50	9.25	9.25	10.25
		12:12 ^d	6.50	7.25	8.25	9.00	9.75	10.5	11.5	11.5	13.0
First Story of Two-Story	16	≤ 1:12	4.00	4.25	4.50	4.75	5.00	5.25	5.25	5.25	5.75
		5:12	4.50	4.75	5.00	5.25	5.50	5.75	6.00	6.00	6.75
		7:12 ^d	4.50	5.00	5.25	5.75	6.00	6.25	6.75	6.75	7.25
		12:12 ^d	5.00	5.25	5.75	6.25	6.50	7.00	7.25	7.25	8.25
	24	≤ 1:12	4.50	4.75	5.00	5.25	5.50	5.75	6.00	6.00	6.75
		5:12	4.75	5.25	5.50	6.00	6.25	6.75	7.00	7.00	7.75
		7:12 ^d	5.25	5.75	6.25	6.75	7.00	7.50	8.00	8.00	9.00
		12:12 ^d	5.50	6.25	6.75	7.25	8.00	8.50	9.00	9.00	10.25
	32	≤ 1:12	4.75	5.00	5.50	5.75	6.25	6.50	6.75	6.75	7.50
		5:12	5.25	5.75	6.25	6.75	7.25	7.50	8.00	8.00	9.00
		7:12 ^d	5.75	6.50	7.00	7.75	8.25	9.00	9.50	9.50	10.75
		12:12 ^d	6.25	7.00	7.75	8.50	9.25	10.0	10.75	10.75	12.25
	40	≤ 1:12	5.00	5.50	5.75	6.25	6.75	7.25	7.50	7.50	8.50
		5:12	5.50	6.25	6.75	7.25	8.00	8.50	9.00	9.00	10.25
		7:12 ^d	6.25	7.00	7.75	8.75	9.50	10.25	11.0	11.0	12.5
		12:12 ^d	7.00	8.00	8.75	9.75	10.75	11.5	12.5	12.5	14.25
	50	≤ 1:12	5.50	6.00	6.50	7.00	7.50	8.00	8.50	8.50	9.50
		5:12	6.00	6.75	7.50	8.25	9.00	9.75	10.5	10.5	11.75
		7:12 ^d	7.00	8.00	9.00	10.0	10.75	11.75	12.75	12.75	14.5
		12:12 ^d	7.75	9.00	10.0	11.25	12.25	13.50	14.75	14.75	17.0
	60	≤ 1:12	5.75	6.50	7.00	7.50	8.25	8.75	9.50	9.50	10.75
		5:12	6.75	7.50	8.25	9.25	10.0	10.75	11.75	11.75	13.25
		7:12 ^d	7.75	9.00	10.0	11.0	12.25	13.25	14.5	14.5	16.75
		12:12 ^d	8.75	10.0	11.5	12.75	14.0	15.5	16.75	16.75	19.5

(continued)

Footnotes to Table R611.7 (9A)

For SI: 1 foot = 304.8 mm; 1 inch = 25.4 mm; 1 pound per square foot = 0.0479kPa.

- a. Table values are based on a 3.5 in thick flat wall. For a 5.5 in thick flat wall, multiply the table values by 0.9. The adjusted values shall not result in solid wall lengths less than 4ft.
- b. Table values are based on a maximum unsupported wall height of 10 ft.
- c. Linear interpolation shall be permitted.
- d. The minimum solid wall lengths shown in the table are based on a building with an end wall length “W” of 60 feet and a roof slope of less than 7:12. For roof slopes of 7:12 or greater and end wall length “W” greater than 30 feet, the minimum solid wall length determined from the table shall be multiplied by: $1 + 0.4[(W-30)/30]$.

TABLE R611.7(9B)
MINIMUM SOLID SIDEWALL LENGTH REQUIREMENTS FOR FLAT ICF WALLS (WIND PARALLEL TO RIDGE) ^{a, b, c, d}

WALL CATEGORY	BUILDING END WALL WIDTH, W (feet)	WIND VELOCITY PRESSURE FROM TABLE R611.7.4 (psf)							
		20	25	30	35	40	45	50	60
One-Story or Top Story of Two-Story		Minimum Solid Wall Length on Building Side Wall (feet)							
	16	4.00	4.00	4.00	4.00	4.25	4.25	4.50	4.75
	24	4.00	4.25	4.50	4.75	4.75	5.00	5.25	5.50
	32	4.50	4.75	5.00	5.25	5.50	6.00	6.25	6.75
	40	5.00	5.50	5.75	6.25	6.75	7.00	7.50	8.25
	50	5.75	6.25	7.00	7.50	8.25	8.75	9.50	10.75
	60	6.50	7.50	8.25	9.25	10.0	10.75	11.75	13.25
First Story of Two-Story	16	4.25	4.50	4.75	5.00	5.25	5.50	5.75	6.50
	24	4.75	5.25	5.50	6.00	6.25	6.75	7.00	8.00
	32	5.50	6.00	6.50	7.00	7.50	8.00	8.75	9.75
	40	6.25	7.00	7.50	8.25	9.00	9.75	10.5	12.0
	50	7.25	8.25	9.25	10.25	11.25	12.25	13.25	15.25
	60	8.50	9.75	11.0	12.25	13.5	15.0	16.25	18.75

For SI: 1 foot = 304.8 mm; 1 inch = 25.4 mm; 1 pound per square foot = 0.0479kPa.

- a. Table values are based on a 3.5 in thick flat wall. For a 5.5 in thick flat wall, multiply the table values by 0.9. The adjusted values shall not result in solid wall lengths less than 4ft.
- b. Table values are based on a maximum unsupported wall height of 10 ft.
- c. Table values are based on a maximum 12:12 roof pitch.
- d. Linear interpolation shall be permitted.

TABLE R611.7(10)
MAXIMUM ALLOWABLE CLEAR SPANS FOR ICF LINTELS IN NONLOAD-BEARING WALLS WITHOUT STIRRUPS^{a,b,c,d}
NO. 4 BOTTOM BAR

MINIMUM LINTEL THICKNESS, T (inches)	MINIMUM LINTEL DEPTH, D (inches)	MAXIMUM CLEAR SPAN	
		Supporting Light-Framed Nonbearing Wall (feet-inches)	Supporting ICF Second Story and Nonbearing Wall (feet-inches)
Flat ICF Lintel			
3.5	8	11-1	3-1
	12	15-11	5-1
	16	16-3	6-11
	20	16-3	8-8
	24	16-3	10-5
5.5	8	16-3	4-4
	12	16-3	7-0
	16	16-3	9-7
	20	16-3	12-0
	24	16-3	14-3
7.5	8	16-3	5-6
	12	16-3	8-11
	16	16-3	12-2
	20	16-3	15-3
	24	16-3	16-3
9.5	8	16-3	6-9
	12	16-3	10-11
	16	16-3	14-10
	20	16-3	16-3
	24	16-3	16-3
Waffle-Grid ICF Lintel			
6 or 8	8	9-1	2-11
	12	13-4	4-10
	16	16-3	6-7
	20	16-3	8-4
	24	16-3	9-11
Screen-Grid Lintel			
6	12	5-8	4-1
	24	16-3	9-1

For SI: 1 foot = 304.8 mm; 1 inch = 25.4 mm; 1 pounds per square foot = 0.0479kPa.

- a. This table is based on concrete with a minimum specified compressive strength of 2,500 psi, reinforcing steel with a minimum yield strength of 40,000 psi and an assumed equivalent rectangular cross section.
- b. This table is not intended to prohibit the use of ICF manufacturers tables based on engineering analysis in accordance with ACI 318.
- c. Deflection criterion is $L/240$, where L is the clear span of the lintel in inches.
- d. Linear interpolation is permitted between lintel depths.

TABLE R611.7(10A)
MINIMUM SOLID END WALL LENGTH REQUIREMENTS FOR WAFFLE AND
SCREEN-GRID ICF WALLS (WIND PERPENDICULAR TO RIDGE)^{a, b, c}

WALL CATEGORY	BUILDING SIDE WALL LENGTH, L (feet)	ROOF SLOPE	WIND VELOCITY PRESSURE FROM TABLE R611.7.4							
			20	25	30	35	40	45	50	60
			Minimum Solid Wall Length on Building End Wall (feet)							
One-Story or Top Story of Two-Story	16	≤1:12	4.00	4.00	4.00	4.00	4.00	4.00	4.00	4.25
		5:12	4.00	4.00	4.00	4.00	4.00	4.25	4.25	4.50
		7:12 ^d	4.00	4.25	4.50	4.75	5.00	5.25	5.50	6.00
		12:12 ^d	4.25	4.75	5.00	5.50	5.75	6.00	6.50	7.00
	24	≤1:12	4.00	4.00	4.00	4.00	4.00	4.25	4.25	4.50
		5:12	4.00	4.00	4.00	4.25	4.50	4.50	4.75	5.00
		7:12 ^d	4.50	4.75	5.00	5.50	5.75	6.25	6.50	7.25
		12:12 ^d	5.00	5.50	6.00	6.50	7.00	7.25	7.75	8.75
	32	≤1:12	4.00	4.00	4.00	4.25	4.25	4.50	4.75	5.00
		5:12	4.00	4.00	4.25	4.50	4.75	5.00	5.25	5.75
		7:12 ^d	4.75	5.25	5.75	6.25	6.50	7.00	7.50	8.50
		12:12 ^d	5.50	6.25	6.75	7.50	8.00	8.75	9.25	10.5
	40	≤1:12	4.00	4.00	4.25	4.50	4.50	4.75	5.00	5.50
		5:12	4.00	4.25	4.50	5.00	5.25	5.50	5.75	6.25
		7:12 ^d	5.25	5.75	6.25	7.00	7.50	8.00	8.50	9.75
		12:12 ^d	6.00	6.75	7.75	8.50	9.25	10.0	10.75	12.25
	50	≤1:12	4.00	4.25	4.50	4.75	5.00	5.25	5.50	6.00
		5:12	4.25	4.75	5.00	5.25	5.50	6.00	6.25	7.00
		7:12 ^d	5.75	6.50	7.00	7.75	8.50	9.25	9.75	11.25
		12:12 ^d	6.75	7.75	8.75	9.75	10.75	11.5	12.5	14.5
	60	≤1:12	4.25	4.50	4.75	5.00	5.25	5.50	5.75	6.50
		5:12	4.50	5.00	5.25	5.75	6.00	6.50	6.75	7.75
		7:12 ^d	6.25	7.00	8.00	8.75	9.50	10.25	11.25	12.75
		12:12 ^d	7.50	8.75	9.75	11.0	12.0	13.25	14.25	16.5
First Story of Two-Story	16	≤1:12	4.25	4.50	4.75	5.00	5.25	5.50	5.75	6.50
		5:12	4.50	5.00	5.25	5.75	6.00	6.50	6.75	7.75
		7:12 ^d	4.75	5.25	5.75	6.25	6.75	7.25	7.75	8.75
		12:12 ^d	5.25	5.75	6.50	7.00	7.50	8.00	8.75	9.75
	24	≤1:12	4.50	5.00	5.25	5.75	6.25	6.50	7.00	7.75
		5:12	5.00	5.75	6.25	6.75	7.25	7.75	8.25	9.25
		7:12 ^d	5.75	6.25	7.00	7.75	8.25	9.00	9.75	11.0
		12:12 ^d	6.25	7.00	7.75	8.50	9.50	10.25	11.0	12.75
	32	≤1:12	5.00	5.50	6.00	6.50	7.00	7.50	8.00	9.00
		5:12	5.75	6.25	7.00	7.75	8.25	9.00	9.75	11.0
		7:12 ^d	6.50	7.25	8.25	9.00	10.0	10.75	11.75	13.5
		12:12 ^d	7.25	8.25	9.25	10.25	11.25	12.5	13.5	15.5
	40	≤1:12	5.50	6.00	6.50	7.25	7.75	8.50	9.00	10.25
		5:12	6.25	7.00	7.75	8.75	9.50	10.25	11.0	12.75
		7:12 ^d	7.25	8.25	9.25	10.5	11.5	12.5	13.75	15.75
		12:12 ^d	8.00	9.50	10.75	12.0	13.25	14.5	15.75	18.25

(continued)

WALL CONSTRUCTION

TABLE R611.7(10A)—continued
MINIMUM SOLID END WALL LENGTH REQUIREMENTS FOR WAFFLE AND
SCREEN-GRID ICF WALLS (WIND PERPENDICULAR TO RIDGE)^{a, b, c}

WALL CATEGORY	BUILDING SIDE WALL LENGTH, L (feet)	ROOF SLOPE	WIND VELOCITY PRESSURE FROM TABLE R611.7.4							
			20	25	30	35	40	45	50	60
			Minimum Solid Wall Length on Building End Wall (feet)							
First Story of Two-Story	50	≤ 1:12	6.00	6.75	7.50	8.00	8.75	9.50	10.25	11.75
		5:12	7.00	8.00	9.00	10.0	11.0	12.0	13.0	14.75
		7:12 ^d	8.25	9.50	10.75	12.25	13.5	14.75	16.0	18.75
		12:12 ^d	9.25	11.0	12.5	14.0	15.5	17.25	18.75	22.0
	60	≤ 1:12	6.50	7.25	8.25	9.00	10.0	10.75	11.75	13.25
		5:12	7.75	8.75	10.0	11.25	12.25	13.5	14.75	17.0
		7:12 ^d	9.25	10.75	12.25	14.0	15.5	17.0	18.5	21.75
		12:12 ^d	10.5	12.25	14.25	16.25	18.0	20.0	21.75	25.5

For SI: 1 foot = 304.8 mm; 1 inch = 25.4 mm; 1 pound per square foot = 0.0479kPa.

a. Table values are based on a 6 in (152.4 mm) thick nominal waffle-grid wall. For a 8 in thick nominal waffle-grid wall, multiply the table values by 0.90.

b. Table values are based on a maximum unsupported wall height of 10 ft.

c. Linear interpolation is permitted.

d. The minimum solid wall lengths shown in the table are based on a building with an end wall length “W” of 60 feet and a roof slope of less than 7:12. For roof slopes of 7:12 or greater and end wall length “W” greater than 30 feet, the minimum solid wall length determined from the table shall be multiplied by: $1 + 0.4 [(W-30)/30]$.

TABLE R611.7(10B)
MINIMUM SOLID SIDE WALL LENGTH REQUIREMENTS FOR 6-INCH WAFFLE AND
SCREEN-GRID ICF WALLS (WIND PARALLEL TO RIDGE)^{a, b, c, d}

WALL CATEGORY	BUILDING END WALL WIDTH, W (feet)	WIND VELOCITY PRESSURE FROM TABLE R611.7.4 (psf)							
		20	25	30	35	40	45	50	60
		Minimum Solid Wall Length on Building Side Wall (feet)							
One-Story or Top Story of Two-Story	16	4.00	4.00	4.00	4.25	4.25	4.50	4.75	5.00
	24	4.00	4.25	4.50	5.00	5.25	5.50	5.75	6.25
	32	4.50	5.00	5.50	5.75	6.25	6.75	7.00	8.00
	40	5.25	6.00	6.50	7.00	7.75	8.25	8.75	10.0
	50	6.50	7.25	8.00	9.00	9.75	10.75	11.5	13.25
	60	7.75	8.75	10.0	11.25	12.25	13.5	14.5	17.0
First Story of Two-Story	16	4.50	4.75	5.25	5.50	5.75	6.25	6.50	7.25
	24	5.00	5.75	6.25	6.75	7.25	7.75	8.25	9.50
	32	6.00	6.75	7.50	8.25	9.00	9.75	10.5	12.0
	40	7.00	8.00	9.00	10.0	11.0	12.0	13.0	15.0
	50	8.50	9.75	11.25	12.5	14.0	15.25	16.75	19.5
	60	10.25	12.0	13.75	15.5	17.25	19.0	21.0	24.5

For SI: 1 foot = 304.8 mm; 1 inch = 25.4 mm; 1 pound per square foot = 0.0479kPa.

a. Table values are based on a 6 in thick nominal waffle-grid wall. For a 8 in thick nominal waffle-grid wall, multiply the table values by 0.90.

b. Table values are based on a maximum unsupported wall height of 10 ft.

c. Table values are based on a maximum 12:12 roof pitch.

d. Linear interpolation shall be permitted.

TABLE R611.7(11)
MINIMUM PERCENTAGE OF SOLID WALL LENGTH ALONG EXTERIOR WALL LINES FOR TOWNHOUSES IN SEISMIC DESIGN CATEGORY C AND ALL BUILDINGS IN SEISMIC DESIGN CATEGORIES D₀, D₁ AND D₂^{a, b}

SEISMIC DESIGN CATEGORY (SDC)	MINIMUM SOLID WALL LENGTH (percent)		
	One-Story or Top Story of Two-Story	Wall Supporting Light-Framed Second Story and Roof	Wall Supporting ICF Second Story and Roof
Townhouses in SDC C ^c	20 percent	25 percent	35 percent
D ₁ ^d	25 percent	30 percent	40 percent
D ₂ ^d	30 percent	35 percent	45 percent

For SI: 1 inch = 25.4 mm; 1 mile per hour = 0.447 m/s.

- Base percentages are applicable for maximum unsupported wall height of 10-feet, light-frame gable construction, and all ICF wall types. These percentages assume that the maximum weight of the interior and exterior wall finishes applied to ICF walls do not exceed 8 psf.
- For all walls, the minimum required length of solid walls shall be based on the table percent value multiplied by the minimum dimension of a rectangle inscribing the overall building plan.
- Walls shall be reinforced with a minimum No. 5 bar (Grade 40 or 60) spaced a maximum of 24 inches on center each way or a No. 4 bar spaced a maximum of 16 inches on center each way. (Grade 40 or 60) spaced at a maximum of 16 inches on center each way.
- Walls shall be constructed with a minimum concrete compressive strength of 3,000 psi and reinforced with minimum #5 rebar (Grade 60 ASTM A 706) spaced a maximum of 18 inches on center each way or No. 4 rebar (Grade 60 ASTM A706) spaced at a maximum of 12 inches (304.8 mm) on center each way. The minimum thickness of flat ICF walls shall be 5.5 inches.

TABLE R611.7.4
WIND VELOCITY PRESSURE FOR DETERMINATION OF MINIMUM SOLID WALL LENGTH^a

WIND SPEED (mph) ^d	VELOCITY PRESSURE (psf)		
	Exposure ^b		
	B	C	D
85	14	19	23
90	16	21	25
100	19	26	31
110	23	32	37
120	27	38	44
130	32	44	52
140	37	51	60
150	43	59	69 ^c

For SI: 1 pound per square foot = 0.0479 kPa; 1 mile per hour = 0.447 m/s.

- Table values are based on ASCE 7-98 Figure 6-4 using a mean roof height of 35 ft.
- Exposure Categories shall be determined in accordance with Section R301.2.1.4.
- Design is required in accordance with ACI 318 and approved manufacturer guidelines.
- Interpolation is permitted between wind speeds.

R611.8.1.1 Top bearing requirements for Seismic Design Categories C, D₀, D₁ and D₂. For townhouses in Seismic Design Category C, wood sill plates attached to ICF walls shall be anchored with Grade A 307, ³/₈-inch-diameter (10 mm) headed anchor bolts embedded a minimum of 7 inches (178 mm) and placed at a maximum spacing of 36 inches (914 mm) on center. For all buildings in Seismic Design Category D₀ or D₁, wood sill plates attached to ICF walls shall be anchored with ASTM A 307, Grade A, ³/₈-inch-diameter (10 mm) headed anchor bolts embedded a minimum of 7 inches (178 mm) and placed at a maximum spacing of 24 inches (610 mm) on center. For all buildings in Seismic Design Category D₂, wood sill plates attached to ICF walls shall

be anchored with ASTM A 307, Grade A, ³/₈-inch-diameter (10 mm) headed anchor bolts embedded a minimum of 7 inches (178 mm) and placed at a maximum spacing of 16 inches (406 mm) on center. Larger diameter bolts than specified herein shall not be used.

For townhouses in Seismic Design Category C, each floor joist perpendicular to an ICF wall shall be attached to the sill plate with an 18-gage [(0.0478 in.) (1.2 mm)] angle bracket using 3 - 8d common nails per leg in accordance with Figure R611.8(1). For all buildings in Seismic Design Category D₀ or D₁, each floor joist perpendicular to an ICF wall shall be attached to the sill plate with an 18-gage [(0.0478 in.) (1.2 mm)] angle bracket using 4 - 8d common nails per leg in accordance with Figure R611.8(1). For all buildings in Seismic Design Category D₂, each floor joist perpendicular to an ICF wall shall be attached to the sill plate with an 18-gage [(0.0478 in.) (1.2 mm)] angle bracket using 6 - 8d common nails per leg in accordance with Figure R611.8(1).

For ICF walls parallel to floor framing in townhouses in Seismic Design Category C, full depth blocking shall be placed at 24 inches (610 mm) on center and shall be attached to the sill plate with an 18-gage [(0.0478 in.) (1.2 mm)] angle bracket using 5 - 8d common nails per leg in accordance with Figure R611.8(6). For ICF walls parallel to floor framing for all buildings in Seismic Design Category D₀ or D₁, full depth blocking shall be placed at 24 inches (610 mm) on center and shall be attached to the sill plate with an 18-gage [(0.0478 in.) (1.2 mm)] angle bracket using 6 - 8d common nails per leg in accordance with Figure R611.8(6). For ICF walls parallel to floor framing for all buildings in Seismic Design Category D₂, full depth blocking shall be placed at 24 inches (610 mm) on center and shall be attached to the sill plate with an 18-gage [(0.0478 in.) (1.2 mm)] angle bracket using 9 - 8d common nails per leg in accordance with Figure R611.8(6).

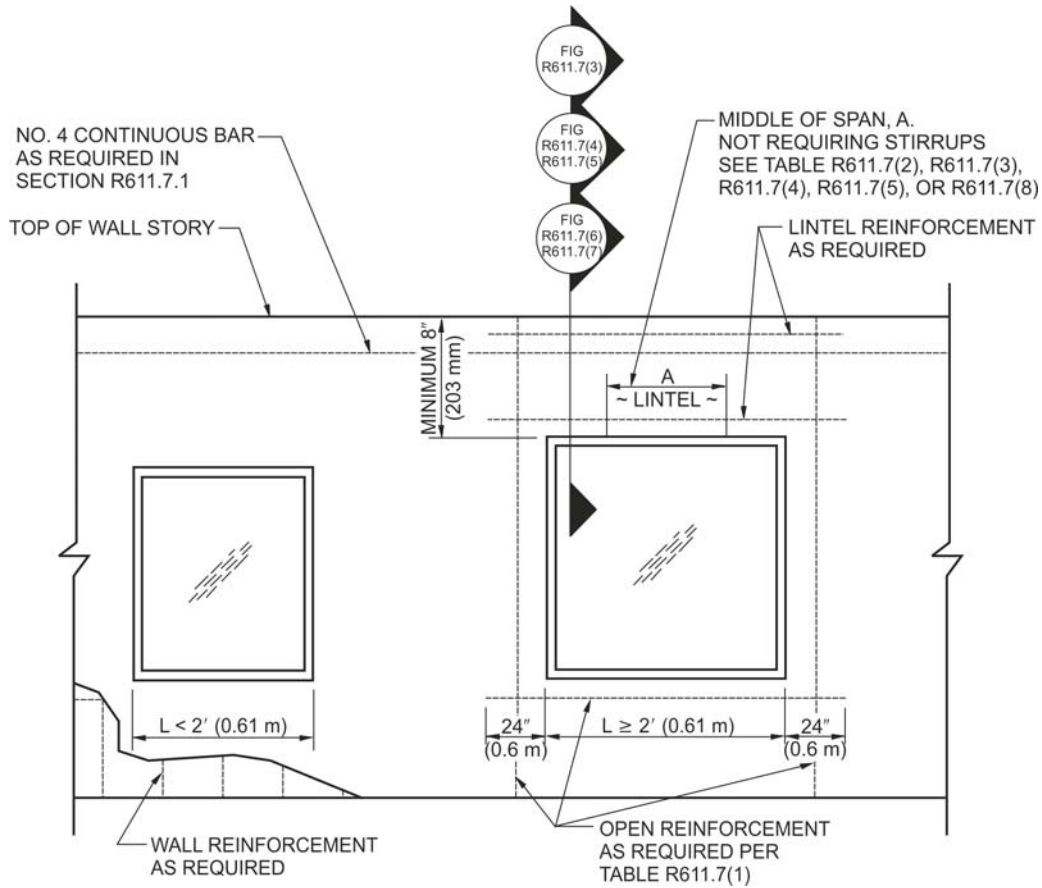
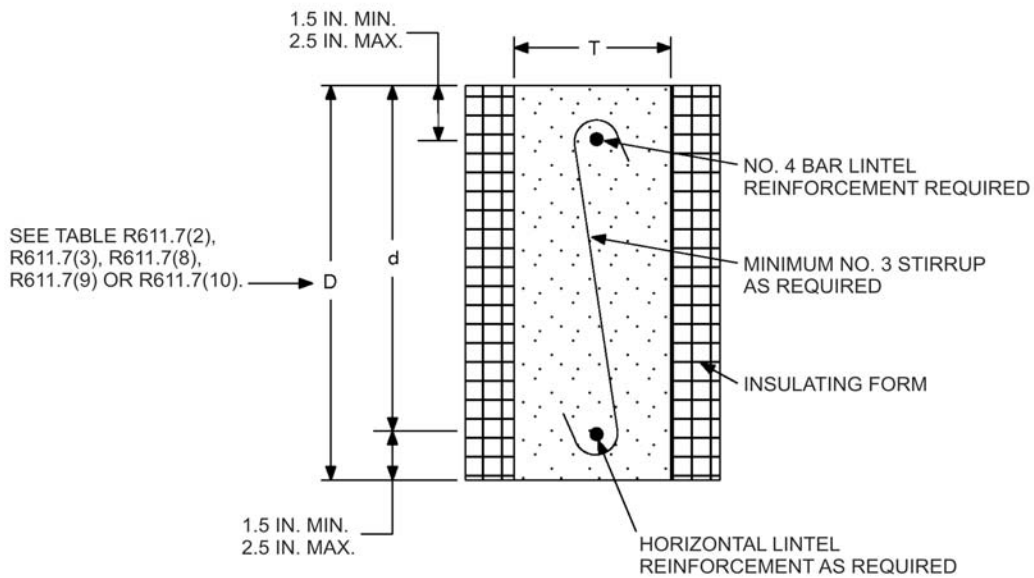
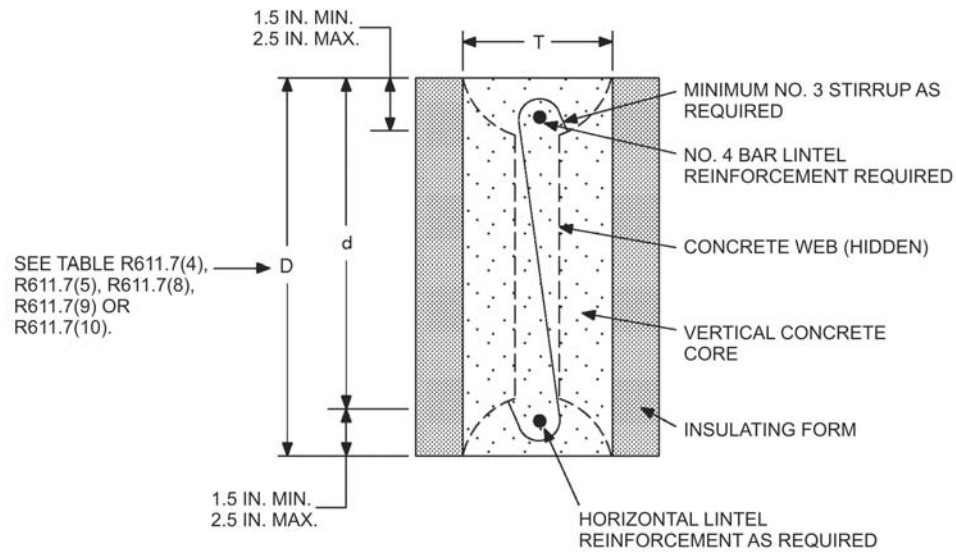

FIGURE R611.7(2)
REINFORCEMENT OF OPENINGS



For SI: 1 inch = 25.4 mm.
NOTE: Section cut through flat wall.

FIGURE R611.7(3)
ICF LINTELS FOR FLAT AND SCREEN-GRID WALLS



For SI: 1 inch = 25.4 mm.

NOTE: Section cut through vertical core of a waffle-grid lintel.

FIGURE R611.7(4)
SINGLE FORM HEIGHT WAFFLE-GRID LINTEL

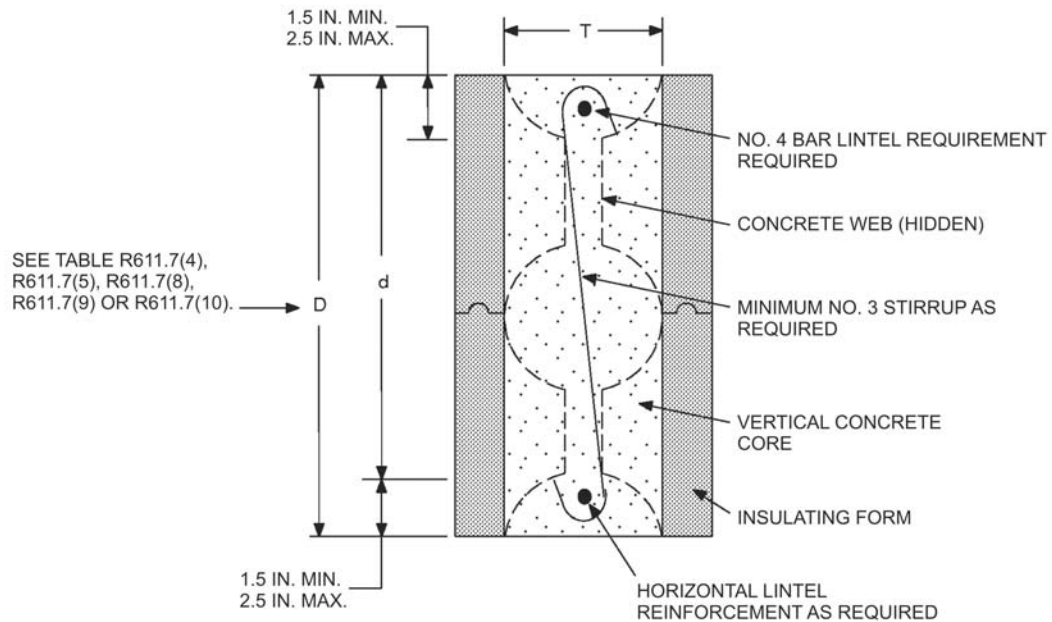

For SI: 1 inch = 25.4 mm.

NOTE: Section cut through vertical core of a waffle-grid lintel.

FIGURE R611.7(5)
DOUBLE FORM HEIGHT WAFFLE-GRID LINTEL

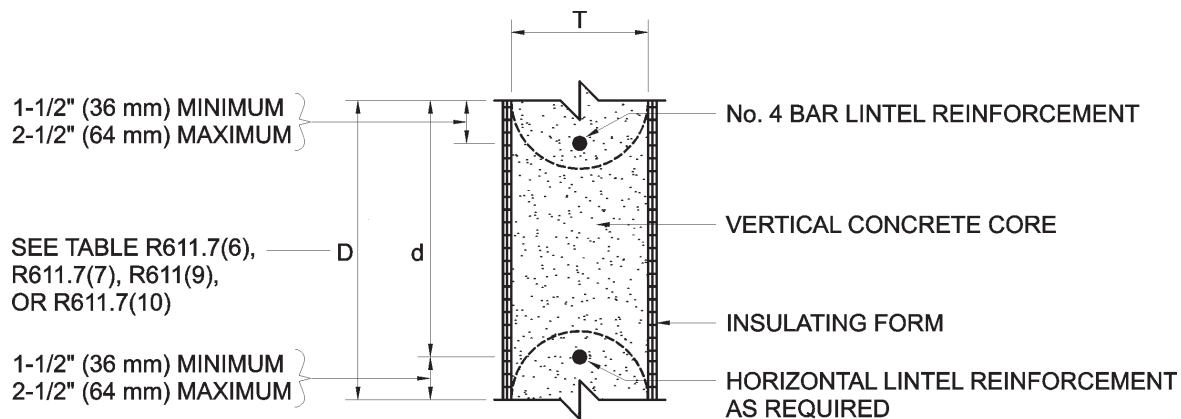

FIGURE R611.7(6)
SINGLE FORM HEIGHT SCREEN-GRID LINTEL

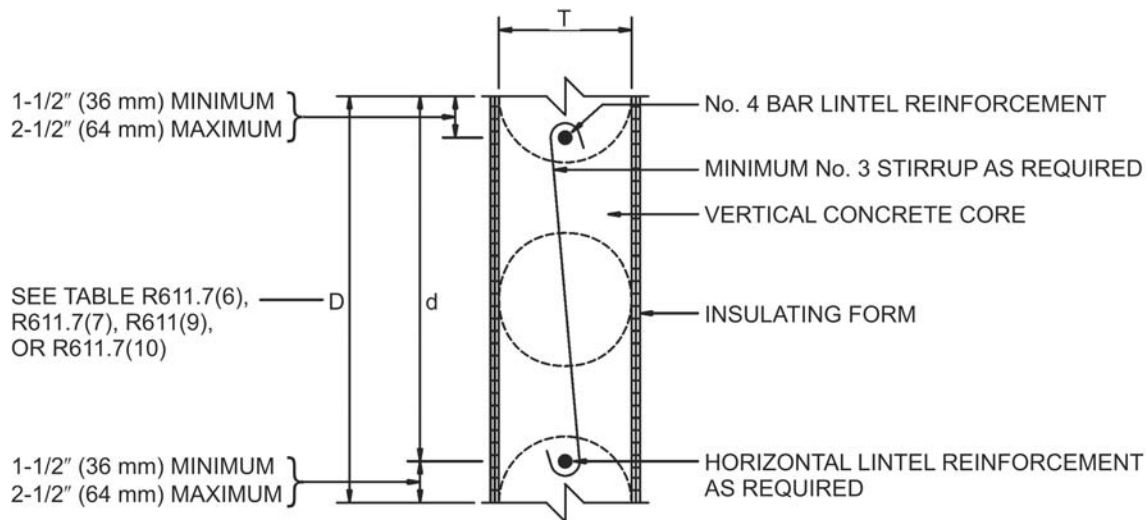

FIGURE R611.7(7)
DOUBLE FORM HEIGHT SCREEN-GRID LINTEL

R611.8.2 Ledger bearing. Wood ledger boards supporting bearing ends of joists or trusses shall be anchored to flat ICF walls with minimum thickness of 5.5 inches (140 mm) and to waffle- or screen-grid ICF walls with minimum nominal thickness of 6 inches (152 mm) in accordance with Figure R611.8(2), R611.8(3), R611.8(4) or R611.8(5) and Table R611.8(1). Wood ledger boards supporting bearing ends of joists or trusses shall be anchored to flat ICF walls with minimum thickness of 3.5 inches (140 mm) in accordance with Figure R611.8(5) and Table R611.8(1). The ledger shall be a minimum 2 by 8, No. 2 Southern Yellow Pine or No. 2 Douglas Fir. Ledgers anchored to nonload-bearing walls to support floor or roof sheathing shall be attached with 1/2 inch (12.7 mm) diameter or headed anchor bolts spaced a maxi-

imum of 6 feet (1829 mm) on center. Anchor bolts shall be embedded a minimum of 4 inches (102 mm) into the concrete measured from the inside face of the insulating form. For insulating forms with a face shell thickness of 1.5 inches (38 mm) or less, the hole in the form shall be a minimum of 4 inches (102 mm) in diameter. For insulating forms with a face shell thicker than 1.5 inches (38 mm), the diameter of the hole in the form shall be increased by 1 inch (25 mm) for each 1/2 inch (13 mm) of additional insulating form face shell thickness. The ledger board shall be in direct contact with the concrete at each bolt location.

R611.8.2.1 Ledger bearing requirements for Seismic Design Categories C, D₀, D₁ and D₂. Additional anchorage mechanisms connecting the wall to the floor system

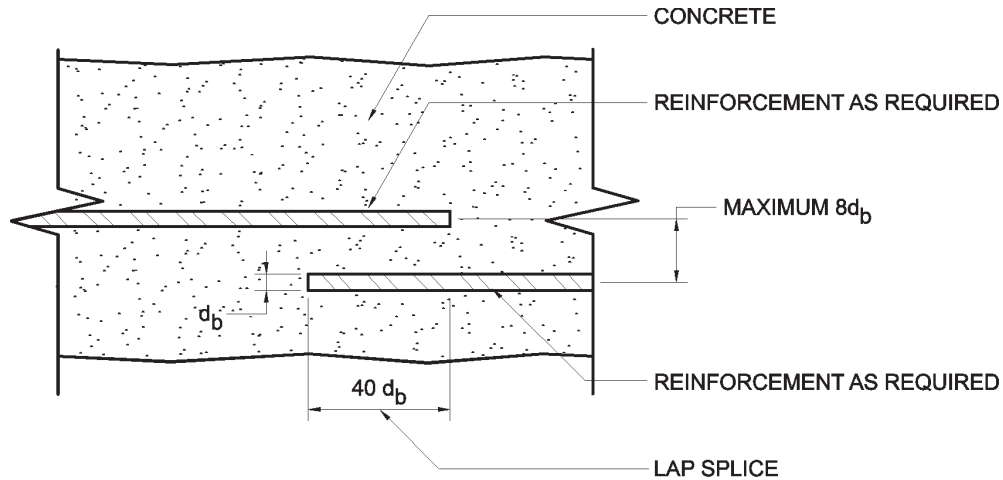

FIGURE R611.7.1.4
LAP SPLICES

shall be installed at a maximum spacing of 6 feet (1829 mm) on center for townhouses in Seismic Design Category C and 4 feet (1220 mm) on center for all buildings in Seismic Design Categories D₀, D₁ and D₂. The additional anchorage mechanisms shall be attached to the ICF wall reinforcement and joist rafters or blocking in accordance with Figures R611.8(1) through R611.8(7). The additional anchorage shall be installed through an oversized hole in the ledger board that is 1/2 inch (13 mm) larger than the anchorage mechanism diameter to prevent combined tension and shear in the mechanism. The blocking shall be attached to floor or roof sheathing in accordance with edge fastener spacing. Such additional anchorage shall not be accomplished by the use of toe nails or nails subject to withdrawal nor shall such anchorage mechanisms induce tension stresses perpendicular to grain in ledgers or nailers. The capacity of such anchors shall result in connections capable of resisting the design values listed in Table R611.8(2). The diaphragm sheathing fasteners applied directly to a ledger shall not be considered effective in providing the additional anchorage required by this section.

Where the additional anchorage mechanisms consist of threaded rods with hex nuts or headed bolts complying with ASTM A 307, Grade A or ASTM F 1554, Grade 36, the design tensile strengths shown in Table R611.9 shall be equal to or greater than the product of the design values listed in Table R611.8(2) and the spacing of the bolts in feet (mm). Anchor bolts shall be embedded as indicated in Table R611.9. Bolts with hooks shall not be used.

R611.8.3 Floor and roof diaphragm construction. Floor and roof diaphragms shall be constructed of wood structural panel sheathing attached to wood framing in accordance with Table R602.3(1) or Table R602.3(2) or to cold-formed steel floor framing in accordance with Table R505.3.1(2) or to cold-formed steel roof framing in accordance with Table R804.3.

R611.8.3.1 Floor and roof diaphragm construction requirements in Seismic Design Categories D₀, D₁ and D₂. The requirements of this section shall apply in addition to those required by Section R611.8.3. Edge spacing of fasteners in floor and roof sheathing shall be 4 inches (102 mm) on center for Seismic Design Category D₀ or D₁ and 3 inches (76 mm) on center for Seismic Design Category D₂. In Seismic Design Categories D₀, D₁ and D₂, all sheathing edges shall be attached to framing or blocking. Minimum sheathing fastener size shall be 0.113 inch (2.8 mm) diameter with a

minimum penetration of 1 3/8 inches (35 mm) into framing members supporting the sheathing. Minimum wood structural panel thickness shall be 7/16 inch (11 mm) for roof sheathing and 2 3/32 inch (18 mm) for floor sheathing. Vertical offsets in floor framing shall not be permitted.

R611.9 ICF wall to top sill plate (roof) connections. Wood sill plates attaching roof framing to ICF walls shall be anchored with minimum 1/2 inch (13 mm) diameter anchor bolt embedded a minimum of 7 inches (178 mm) and placed at 6 feet (1829 mm) on center in accordance with Figure R611.9. Anchor bolts shall be located in the cores of waffle-grid and screen-grid ICF walls. Roof assemblies subject to wind uplift pressure of 20 pounds per square foot (1.44 kPa) or greater as established in Table R301.2(2) shall have rafter or truss ties provided in accordance with Table R802.11.

R611.9.1 ICF wall to top sill plate (roof) connections for Seismic Design Categories C, D₀, D₁ and D₂. The requirements of this section shall apply in addition to those required by Section R611.9. The top of an ICF wall at a gable shall be attached to an attic floor in accordance with Section R611.8.1.1. For townhouses in Seismic Design Category C, attic floor diaphragms shall be constructed of structural wood sheathing panels attached to wood framing in accordance with Table R602.3(1) or Table R602.3(2). Edge spacing of fasteners in attic floor sheathing shall be 4 inches (102 mm) on center for Seismic Design Category D₀ or D₁ and 3 inches (76 mm) on center for Seismic Design Category D₂. In Seismic Design Categories D₀, D₁ and D₂, all sheathing edges shall be attached to framing or blocking. Minimum sheathing fastener size shall be 0.113 inch (2.8 mm) diameter with a

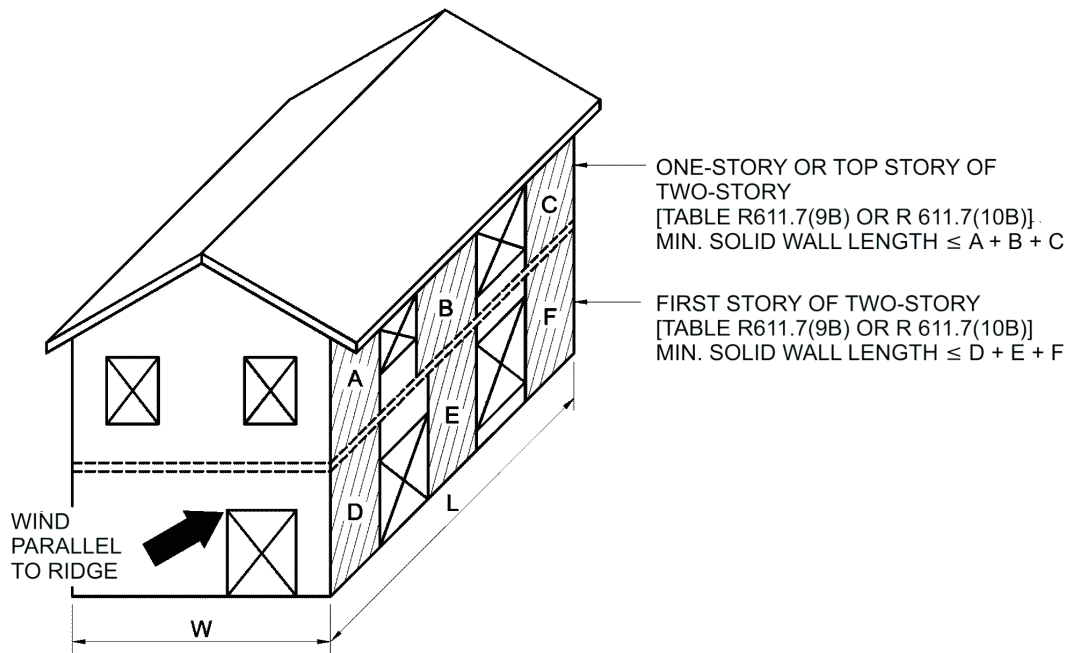
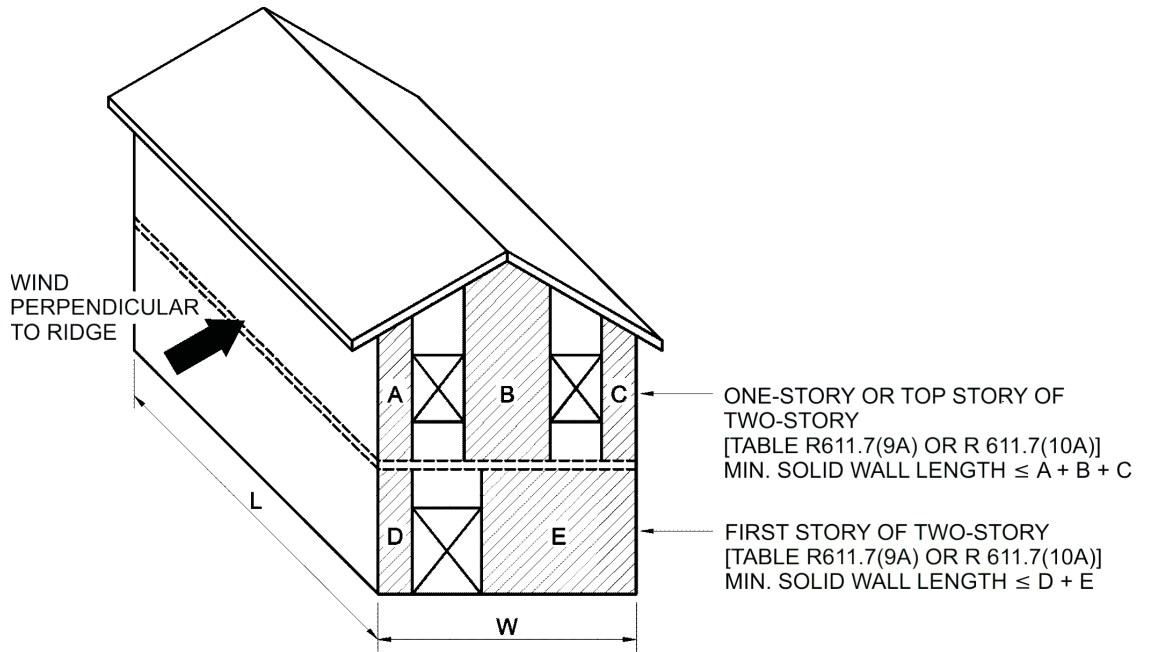

NOTE: EACH WALL SEGMENT (A, B, C, D AND F) MUST MEET THE MINIMUM SOLID WALL SEGMENT LENGTH IN ORDER TO APPLICABLE TO THE MINIMUM SOLID WALL LENGTH EQUATIONS ABOVE.

FIGURE R611.7.4
MINIMUM SOLID WALL LENGTH

TABLE R611.8(1)
FLOOR LEDGER-ICF WALL CONNECTION (SIDE-BEARING CONNECTION) REQUIREMENTS^{a, b, c}

MAXIMUM FLOOR CLEAR SPAN ^d (feet)	MAXIMUM ANCHOR BOLT SPACING ^e (inches)			
	Staggered $\frac{1}{2}$ -inch-diameter anchor bolts	Staggered $\frac{5}{8}$ -inch-diameter anchor bolts	Two $\frac{1}{2}$ -inch-diameter anchor bolts ^f	Two $\frac{5}{8}$ -inch-diameter anchor bolts ^f
8	18	20	36	40
10	16	18	32	36
12	14	18	28	36
14	12	16	24	32
16	10	14	20	28
18	9	13	18	26
20	8	11	16	22
22	7	10	14	20
24	7	9	14	18
26	6	9	12	18
28	6	8	12	16
30	5	8	10	16
32	5	7	10	14

For SI: 1 inch = 25.4 mm, 1 foot = 304.8 mm.

- Minimum ledger board nominal depth shall be 8 inches. The thickness of the ledger board shall be a minimum of 2 inches. Thickness of ledger board is in nominal lumber dimensions. Ledger board shall be minimum No. 2 Grade.
- Minimum edge distance shall be 2 inches for $\frac{1}{2}$ -inch-diameter anchor bolts and 2.5 inches for $\frac{5}{8}$ -inch-diameter anchor bolts.
- Interpolation is permitted between floor spans.
- Floor span corresponds to the clear span of the floor structure (i.e., joists or trusses) spanning between load-bearing walls or beams.
- Anchor bolts shall extend through the ledger to the center of the flat ICF wall thickness or the center of the horizontal or vertical core thickness of the waffle-grid or screen-grid ICF wall system.
- Minimum vertical distance between bolts shall be 1.5 inches for $\frac{1}{2}$ -inch-diameter anchor bolts and 2 inches for $\frac{5}{8}$ -inch-diameter anchor bolts.

minimum penetration of $1\frac{3}{8}$ inches (35 mm) into framing members supporting the sheathing. Minimum wood structural panel thickness shall be $\frac{7}{16}$ inch (11 mm) for the attic floor sheathing. Where hipped roof construction is used, the use of a structural attic floor is not required.

For townhouses in Seismic Design Category C, wood sill plates attached to ICF walls shall be anchored with ASTM A 307, Grade A, $\frac{3}{8}$ -inch (10 mm) diameter anchor bolts embedded a minimum of 7 inches (178 mm) and placed at a maximum spacing of 36 inches (914 mm) on center. For all buildings in Seismic Design Category D₀ or D₁, wood sill plates attached to ICF walls shall be anchored with ASTM A 307, Grade A, $\frac{3}{8}$ -inch (10 mm) diameter anchor bolts embedded a minimum of 7 inches (178 mm) and placed at a maximum spacing of 16 inches (406 mm) on center. For all buildings in Seismic Design Category D₂, wood sill plates attached to ICF walls shall be anchored with ASTM A 307, Grade A, $\frac{3}{8}$ -inch (10 mm) diameter anchor bolts embedded a minimum of 7 inches (178 mm) and placed at a maximum spacing of 16 inches (406 mm) on center.

For townhouses in Seismic Design Category C, each floor joist shall be attached to the sill plate with an 18-gage [(0.0478 in.) (1.2 mm)] angle bracket using 3 - 8d common nails per leg in accordance with Figure R611.8(1). For all

buildings in Seismic Design Category D₀ or D₁, each floor joist shall be attached to the sill plate with an 18-gage [(0.0478 in.) (1.2 mm)] angle bracket using 4 - 8d common nails per leg in accordance with Figure R611.8(1). For all buildings in Seismic Design Category D₂, each floor joist shall be attached to the sill plate with an 18-gage [(0.0478 in.) (1.2 mm)] angle bracket using 6-8d common nails per leg in accordance with Figure R611.8(1).

Where hipped roof construction is used without an attic floor, the following shall apply. For townhouses in Seismic Design Category C, each rafter shall be attached to the sill plate with an 18-gage [(0.0478 in.) (1.2 mm)] angle bracket using 3 - 8d common nails per leg in accordance with Figure R611.9. For all buildings in Seismic Design Category D₀ or D₁, each rafter shall be attached to the sill plate with an 18-gage [(0.0478 in.) (1.2 mm)] angle bracket using 4 - 8d common nails per leg in accordance with Figure R611.9. For all buildings in Seismic Design Category D₂, each rafter shall be attached to the sill plate with an 18-gage [(0.0478 in.) (1.2 mm)] angle bracket using 6-8d common nails per leg in accordance with Figure R611.9.

TABLE R611.8(2)
DESIGN VALUES (PLF) FOR FLOOR JOIST-TO-WALL ANCHORS REQUIRED FOR TOWNHOUSES
IN SEISMIC DESIGN CATEGORY C AND ALL BUILDINGS IN SEISMIC DESIGN CATEGORIES D₀, D₁ AND D₂^{a,b}

WALL TYPE	SEISMIC DESIGN CATEGORY		
	C	D ₀ or D ₁	D ₂
Flat 3.5	193	NP	NP
Flat 5.5	303	502	708
Flat 7.5	413	685	965
Flat 9.5	523	867	1,223
Waffle 6	246	409	577
Waffle 8	334	555	782
Screen 6	233	387	546

For SI: 1 pound per linear foot = 1.488 kg/m.

NP = Not Permitted

- a. Table values are based on IBC Equation 16-64 using a tributary wall height of 11 feet. Table values shall be permitted to be reduced for tributary wall heights less than 11 feet by multiplying the table values by X/11, where X is the tributary wall height.
- b. Values may be reduced by 30 percent when used for ASD.

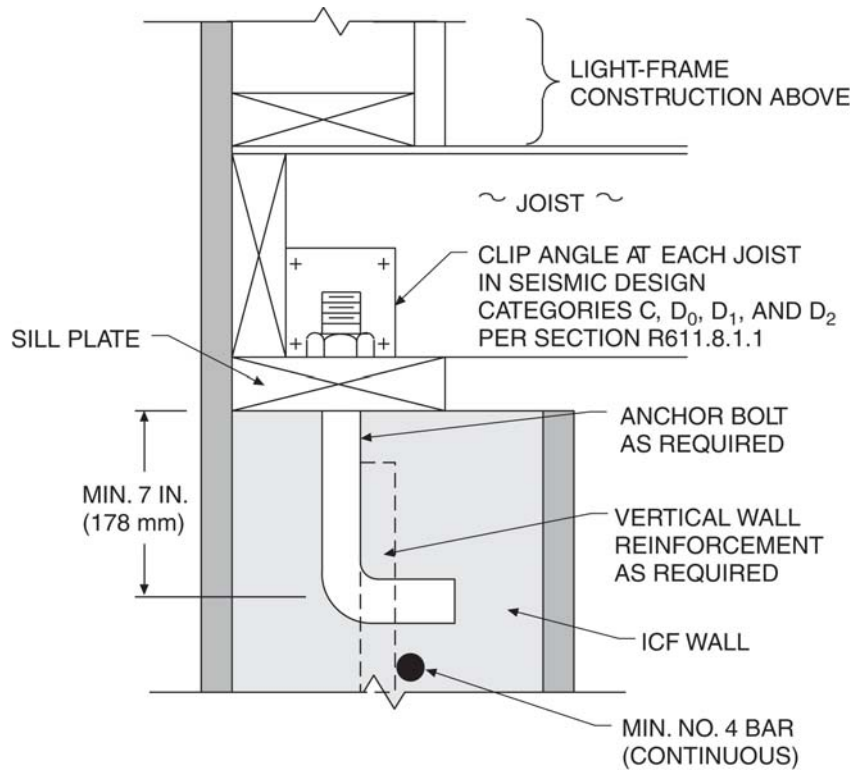
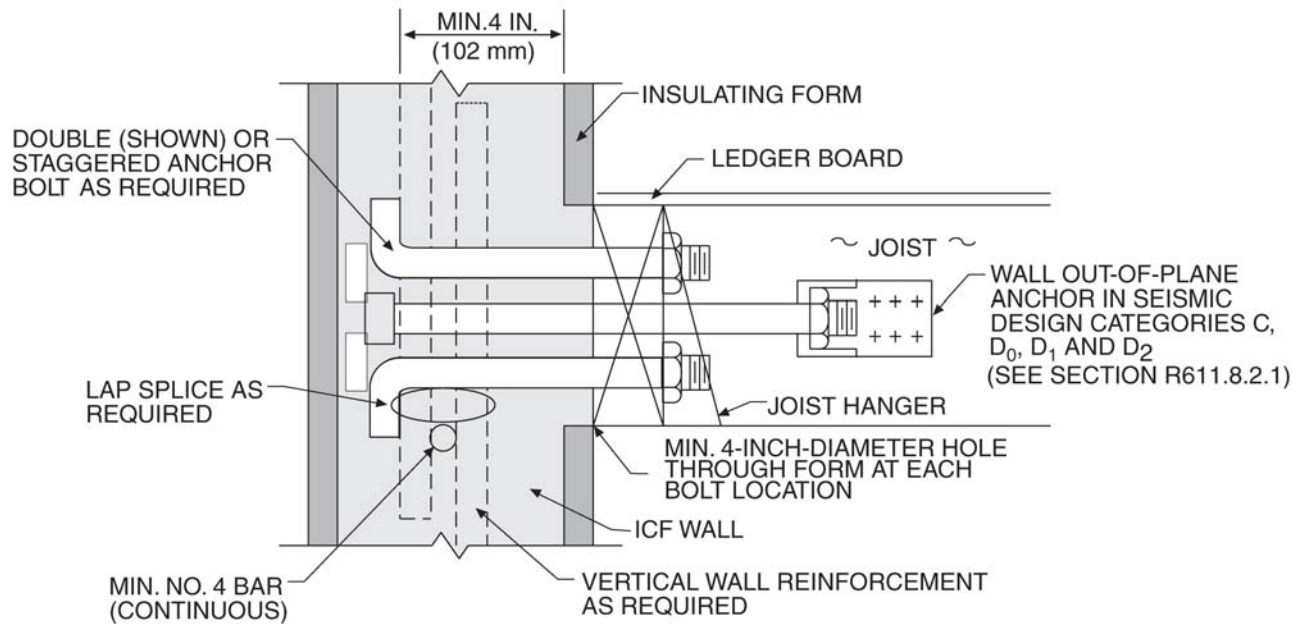

FIGURE R611.8(1)
SECTION CUT THROUGH FLAT WALL OR VERTICAL CORE
OF WAFFLE- OR SCREEN-GRID WALL



For SI: 1 inch = 25.4 mm.

NOTE: Section cut through flat wall or vertical core of a waffle- or screen-grid wall.

FIGURE R611.8(2)
FLOOR LEDGER—ICF WALL CONNECTION (SIDE-BEARING CONNECTION)

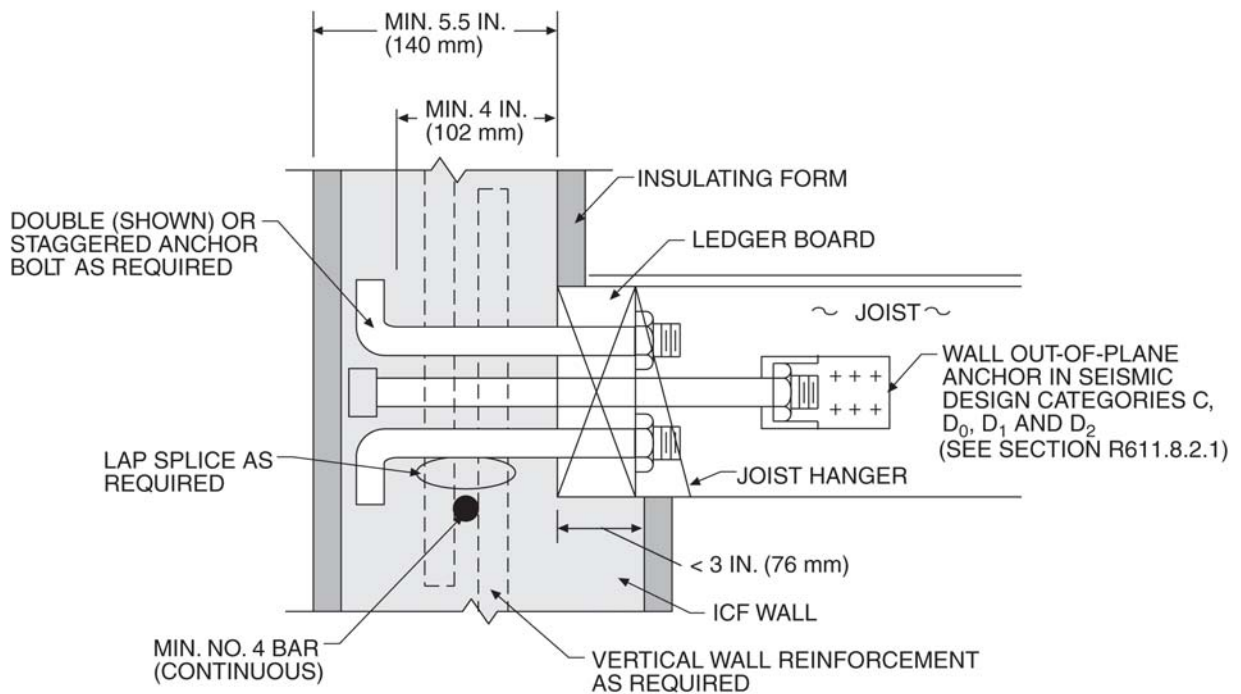

For SI: 1 inch = 25.4 mm.

NOTE: Section cut through flat wall or vertical core of a waffle- or screen-grid wall.

FIGURE R611.8(3)
FLOOR LEDGER—ICF WALL CONNECTION (LEDGE-BEARING CONNECTION)

WALL CONSTRUCTION

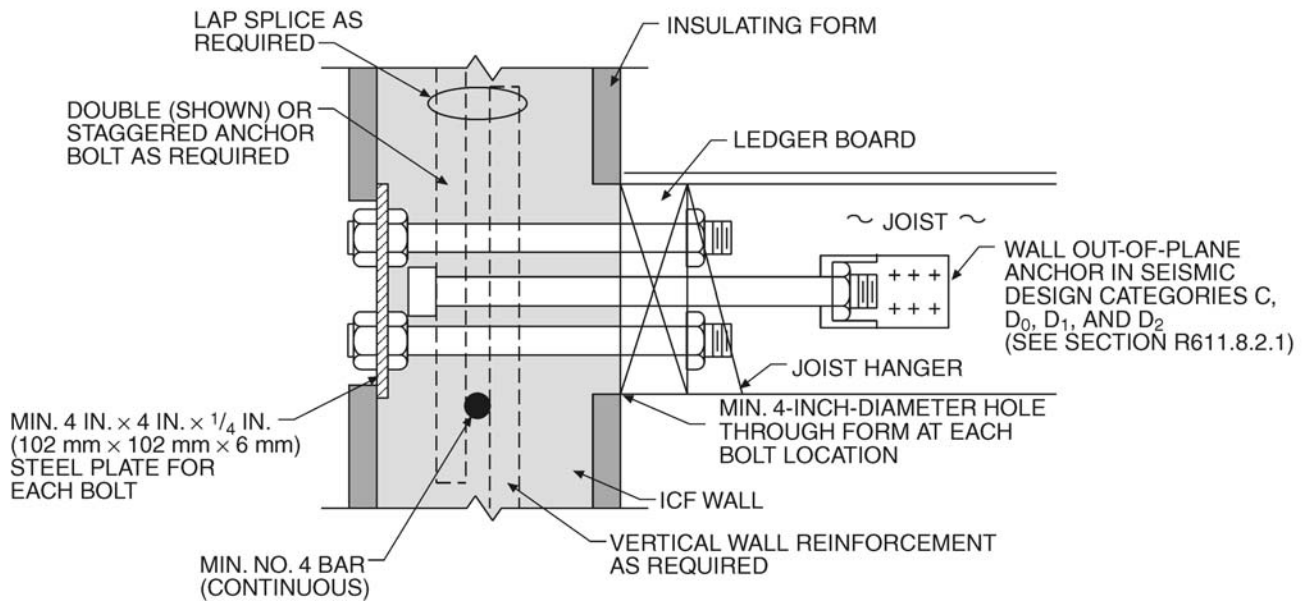

For SI: 1 inch = 25.4 mm.
NOTE: Section cut through flat wall.

FIGURE R611.8(4)
WOOD FLOOR LEDGER—ICF WALL SYSTEM CONNECTION
(THROUGH-BOLT SIDE-BEARING CONNECTION)

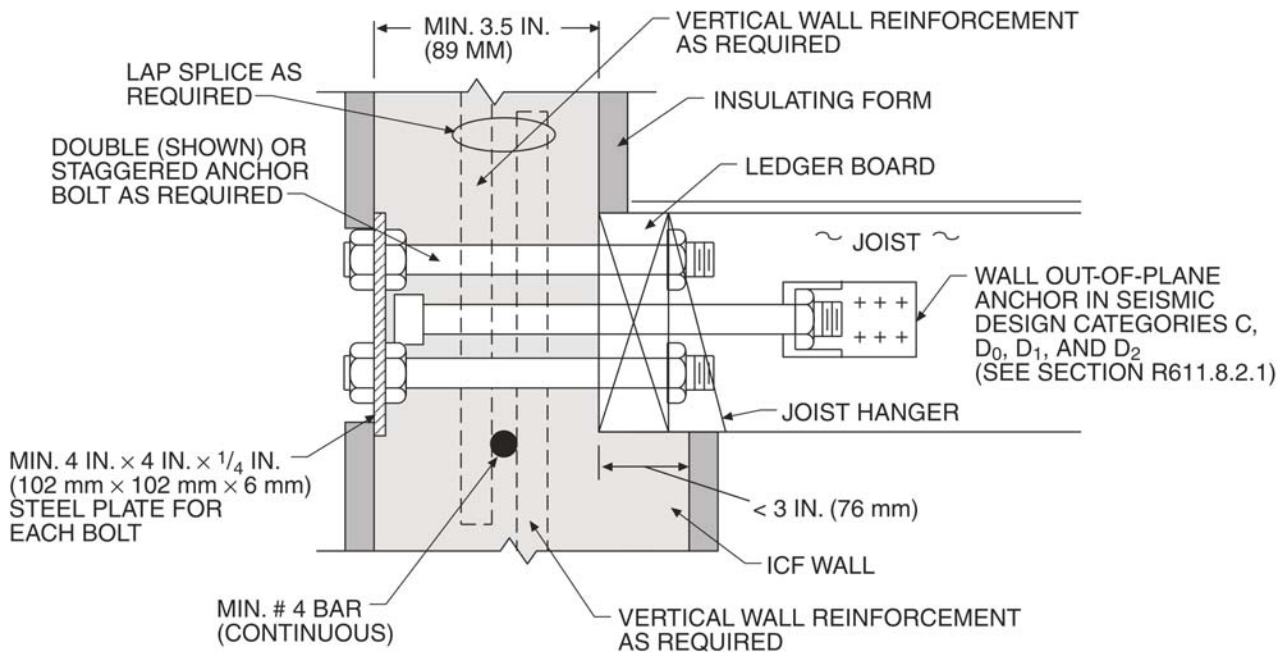

For SI: 1 inch = 25.4 mm.
NOTE: Section cut through flat wall.

FIGURE R611.8(5)
FLOOR LEDGER—ICF WALL CONNECTION

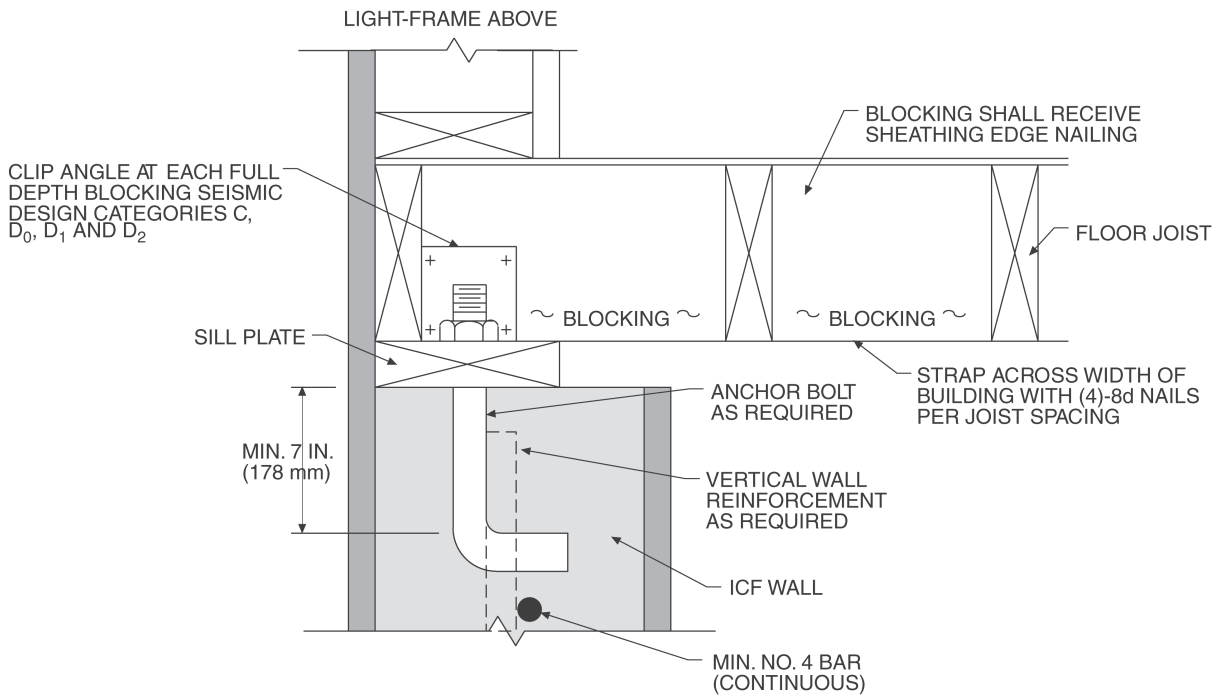

FIGURE R611.8(6)
ANCHORAGE REQUIREMENTS FOR TOP BEARING WALLS FOR TOWNHOUSES IN SEISMIC DESIGN CATEGORY C AND ALL BUILDINGS IN SEISMIC DESIGN CATEGORIES D₀, D₁, AND D₂ FOR FLOOR FRAMING PARALLEL TO WALL

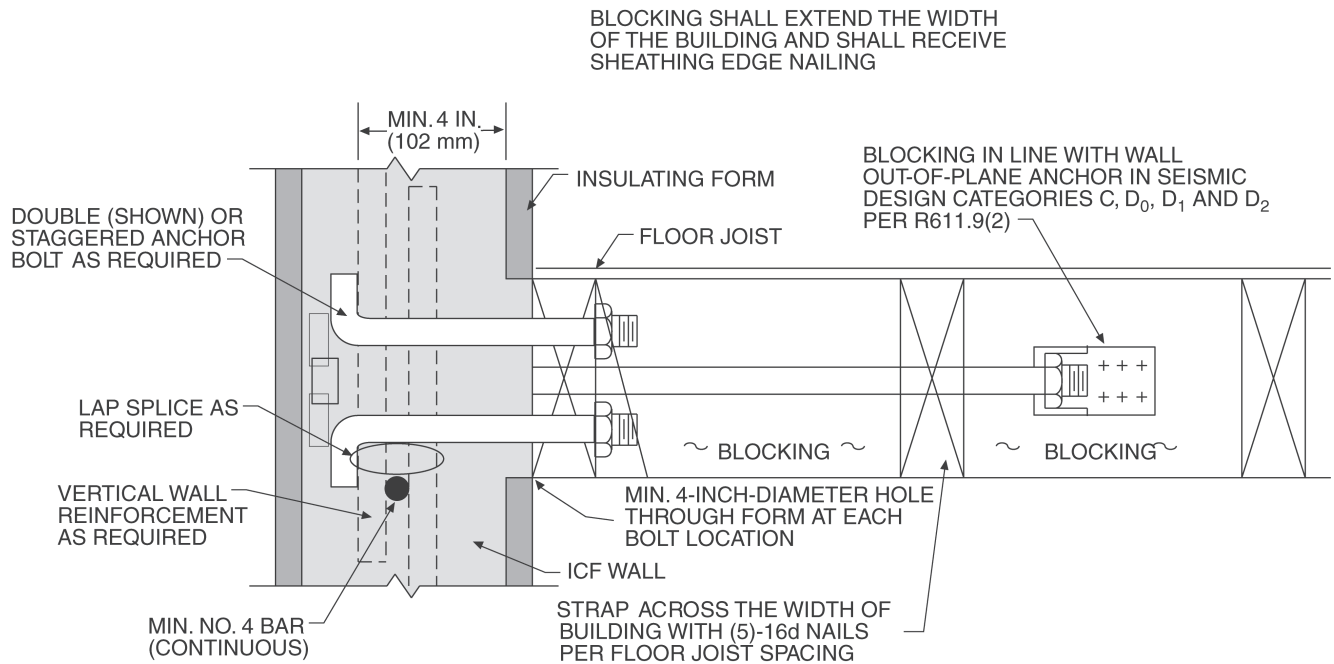

FIGURE R611.8(7)
ANCHORAGE REQUIREMENTS FOR LEDGER BEARING WALLS FOR TOWNHOUSES IN SEISMIC DESIGN CATEGORY C AND ALL BUILDINGS IN SEISMIC DESIGN CATEGORIES D₀, D₁ AND D₂ FOR FLOOR FRAMING PARALLEL TO WALL

**TABLE R611.9
DESIGN TENSILE STRENGTH OF HEADED BOLTS CAST IN CONCRETE^a**

DIAMETER OF BOLT (inches)	MINIMUM EMBEDMENT DEPTH (inches)	DESIGN TENSILE STRENGTH ^b (pounds)
1/4	2	1040
3/8 with washer ^c	2 3/4 ^d	2540
1/2 with washer ^c	4 ^d	4630

For SI: 1 pound per square inch = 6.895 kPa.

- a. Applicable to concrete of all strengths. See Notes (c) and (d).
- b. Values are based on ASTM F 1554, Grade 36 bolts. Where ASTM A 307, Grade A headed bolts are used, the strength shall be increased by 1.034.
- c. A hardened washer shall be installed at the nut embedded in the concrete or head of the bolt to increase the bearing area. The washer is not required where the concrete strength is 4000 psi or more.
- d. Embedment depth shall be permitted to be reduced 1/4-inch where 4000 psi concrete is used.

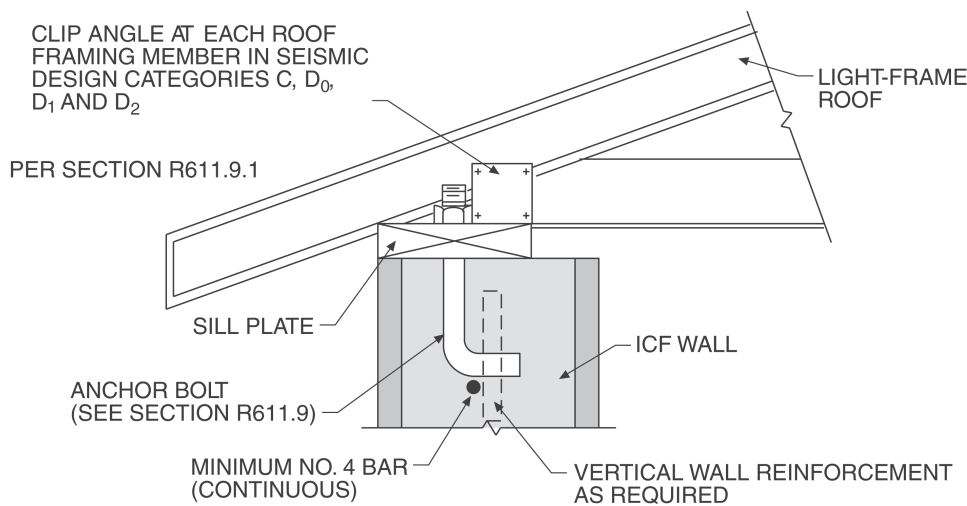

NOTE: Section cut through flat wall or vertical core of a waffle- or screen-grid wall.

**FIGURE R611.9
ROOF SILL PLATE—ICF WALL CONNECTION**

**SECTION R612
CONVENTIONALLY FORMED CONCRETE WALL
CONSTRUCTION**

R612.1 General. Conventionally formed concrete walls with flat surfaces shall be designed and constructed in accordance with the provisions of Section R611 for Flat ICF walls or in accordance with the provisions of ACI 318.

**SECTION R613
EXTERIOR WINDOWS AND GLASS DOORS**

R613.1 General. This section prescribes performance and construction requirements for exterior window systems installed in wall systems. Windows shall be installed and flashed in accordance with the manufacturer’s written installation instructions. Written installation instructions shall be provided by the manufacturer for each window.

R613.2 Window sills. In dwelling units, where the opening of an operable window is located more than 72 inches (1829 mm) above the finished grade or surface below, the lowest part of

the clear opening of the window shall be a minimum of 24 inches (610 mm) above the finished floor of the room in which the window is located. Glazing between the floor and 24 inches (610 mm) shall be fixed or have openings through which a 4-inch-diameter (102 mm) sphere cannot pass.

Exceptions:

1. Windows whose openings will not allow a 4-inch-diameter (102 mm) sphere to pass through the opening when the opening is in its largest opened position.
2. Openings that are provided with window guards that comply with ASTM F 2006 or F 2090.

R613.3 Performance. Exterior windows and doors shall be designed to resist the design wind loads specified in Table R301.2(2) adjusted for height and exposure per Table R301.2(3).

[W] R613.4 Testing and labeling. Exterior windows and sliding doors shall be tested by an approved independent laboratory, and bear a label identifying manufacturer, performance charac-

teristics and approved inspection agency to indicate compliance with AAMA/WDMA/CSA 101/I.S.2/A440. Exterior side-hinged doors shall be tested and labeled as conforming to AAMA/WDMA/CSA 101/I.S.2/A440 or comply with Section R613.6.

Exceptions:

1. Decorative glazed openings.
2. Custom exterior windows and doors manufactured by a small business are exempt from all testing requirements in Section R613 of the *International Residential Code* provided they meet the applicable provisions of Chapter 24 of the *International Building Code*.

R613.4.1 Comparative analysis. Structural wind load design pressures for window and door units smaller than the size tested in accordance with Section R613.4 shall be permitted to be higher than the design value of the tested unit provided such higher pressures are determined by accepted engineering analysis. All components of the small unit shall be the same as those of the tested unit. Where such calculated design pressures are used, they shall be validated by an additional test of the window or door unit having the highest allowable design pressure.

R613.5 Vehicular access doors. Vehicular access doors shall be tested in accordance with either ASTM E 330 or ANSI/DASMA 108, and shall meet the acceptance criteria of ANSI/DASMA 108.

R613.6 Other exterior window and door assemblies. Exterior windows and door assemblies not included within the scope of Section R613.4 or Section R613.5 shall be tested in accordance with ASTM E 330. Glass in assemblies covered by this exception shall comply with Section R308.5.

R613.7 Wind-borne debris protection. Protection of exterior windows and glass doors in buildings located in wind-borne debris regions shall be in accordance with Section R301.2.1.2.

R613.7.1 Fenestration testing and labeling. Fenestration shall be tested by an approved independent laboratory, listed by an approved entity, and bear a label identifying manufacturer, performance characteristics, and approved inspection agency to indicate compliance with the requirements of the following specification:

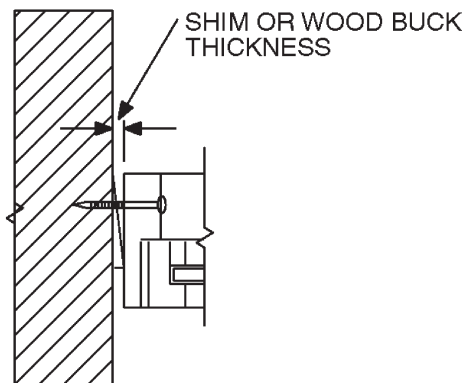

**FIGURE R613.8(1)
THROUGH THE FRAME**

1. ASTM E 1886 and ASTM E 1996; or
2. AAMA 506.

R613.8 Anchorage methods. The methods cited in this section apply only to anchorage of window and glass door assemblies to the main force-resisting system.

R613.8.1 Anchoring requirements. Window and glass door assemblies shall be anchored in accordance with the published manufacturer’s recommendations to achieve the design pressure specified. Substitute anchoring systems used for substrates not specified by the fenestration manufacturer shall provide equal or greater anchoring performance as demonstrated by accepted engineering practice.

R613.8.2 Anchorage details. Products shall be anchored in accordance with the minimum requirements illustrated in Figures R613.8(1), R613.8(2), R613.8(3), R613.8(4), R613.8(5), R613.8(6), R613.8(7) and R613.8(8).

R613.8.2.1 Masonry, concrete or other structural substrate. Where the wood shim or buck thickness is less than 1½ inches (38 mm), window and glass door assemblies shall be anchored through the jamb, or by jamb clip and anchors shall be embedded directly into the masonry, concrete or other substantial substrate material. Anchors shall adequately transfer load from the window or door frame into the rough opening substrate [see Figures R613.8(1) and R613.8(2).]

Where the wood shim or buck thickness is 1½ inches (38 mm) or more, the buck is securely fastened to the masonry, concrete or other substantial substrate, and the buck extends beyond the interior face of the window or door frame, window and glass door assemblies shall be anchored through the jamb, or by jamb clip, or through the flange to the secured wood buck. Anchors shall be embedded into the secured wood buck to adequately transfer load from the window or door frame assembly [Figures R613.8(3), R613.8(4) and R613.8(5)].

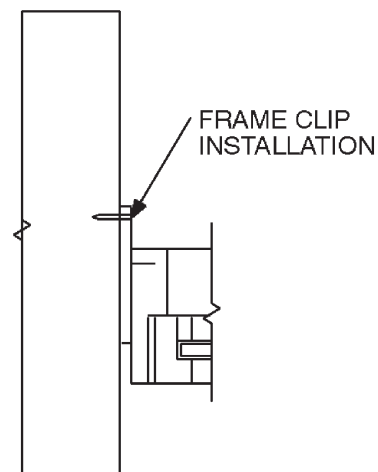

APPLY FRAME CLIP TO WINDOW OR DOOR IN ACCORDANCE WITH PUBLISHED MANUFACTURER'S RECOMMENDATIONS.

**FIGURE R613.8(2)
FRAME CLIP**

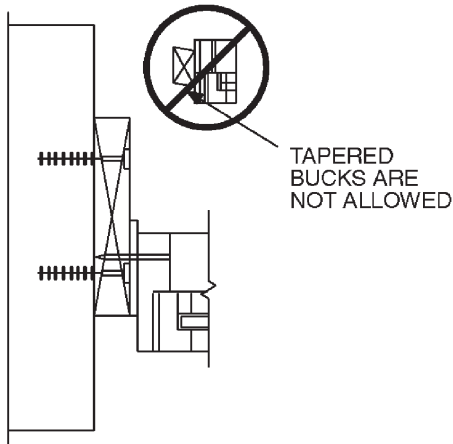

THROUGH THE FRAME ANCHORING METHOD. ANCHORS SHALL BE PROVIDED TO TRANSFER LOAD FROM THE WINDOW OR DOOR FRAME INTO THE ROUGH OPENING SUBSTRATE.

**FIGURE R613.8(3)
THROUGH THE FRAME**

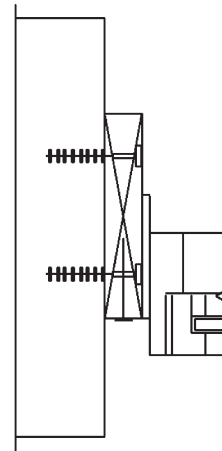

APPLY ANCHORS THROUGH FLANGE IN ACCORDANCE WITH PUBLISHED MANUFACTURER'S RECOMMENDATIONS.

**FIGURE R613.8(5)
THROUGH THE FLANGE**

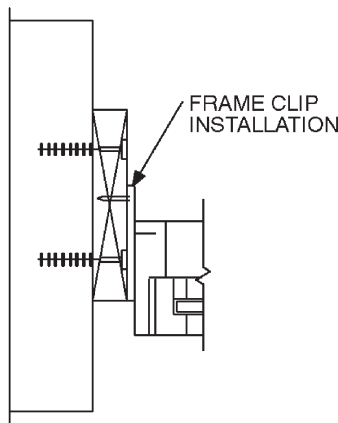

APPLY FRAME CLIP TO WINDOW OR DOOR FRAME IN ACCORDANCE WITH PUBLISHED MANUFACTURER'S RECOMMENDATIONS. ANCHORS SHALL BE PROVIDED TO TRANSFER LOAD FROM THE FRAME CLIP INTO THE ROUGH OPENING SUBSTRATE.

**FIGURE R613.8(4)
FRAME CLIP**

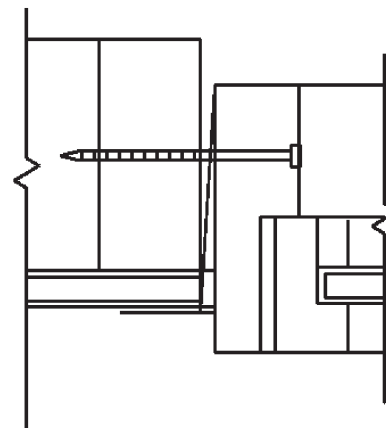

**FIGURE R613.8(6)
THROUGH THE FRAME**

R613.8.2.2 Wood or other approved framing material.

Where the framing material is wood or other approved framing material, window and glass door assemblies shall be anchored through the frame, or by frame clip, or through the flange. Anchors shall be embedded into the frame construction to adequately transfer load [Figures R613.8(6), R613.8(7) and R613.8(8)].

R613.9 Mullions occurring between individual window and glass door assemblies.

R613.9.1 Mullions. Mullions shall be tested by an approved testing laboratory in accordance with AAMA 450, or be engineered in accordance with accepted engi-

neering practice. Mullions tested as stand-alone units or qualified by engineering shall use performance criteria cited in Sections R613.9.2, R613.9.3 and R613.9.4. Mullions qualified by an actual test of an entire assembly shall comply with Sections R613.9.2 and R613.9.4.

R613.9.2 Load transfer. Mullions shall be designed to transfer the design pressure loads applied by the window and door assemblies to the rough opening substrate.

R613.9.3 Deflection. Mullions shall be capable of resisting the design pressure loads applied by the window and door assemblies to be supported without deflecting more than $L/175$, where L is the span of the mullion in inches.

R613.9.4 Structural safety factor. Mullions shall be capable of resisting a load of 1.5 times the design pressure loads applied by the window and door assemblies to be supported without exceeding the appropriate material stress levels. If tested by an approved laboratory, the 1.5 times the design pressure load shall be sustained for 10 seconds, and the per-

manent deformation shall not exceed 0.4 percent of the mul-
 lion span after the 1.5 times design pressure load is removed.

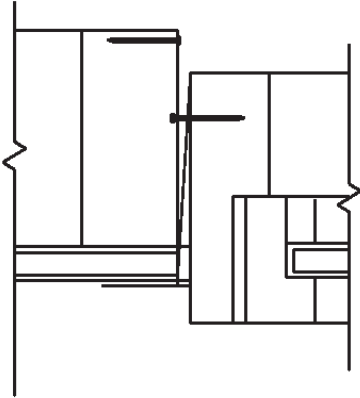

FIGURE R613.8(7)
 FRAME CLIP

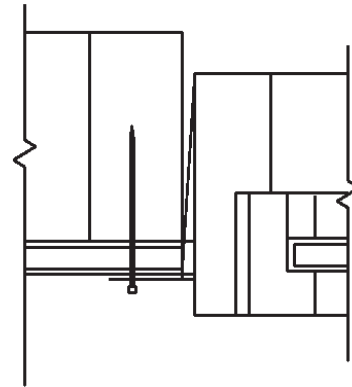

FIGURE R613.8(8)
 THROUGH THE FLANGE

